

**SOCIAL MEDIA TOOLS AND PROJECT PERFORMANCE: THE CASE OF
SAFARICOM LTD**

PRESENTED BY

KIZITO WACHIYEH

D61/68980/2013

A Research Project Report Presented in Partial Fulfillment of the Requirements for the
Degree of Master of Business Administration (MBA), School of Business, University of
Nairobi

November 2016

DECLARATION

I declare that this research report was composed by myself, and that the work contained herein is my own except where explicitly stated otherwise in the text, and that this work has not been submitted for any other degree or professional qualification to the best of my knowledge, except as specified.

Signed: Date:

Kizito Wachiyeh

Reg. No.: D61/68980/2013

This research proposal has been submitted for examination with my approval as university supervisor.

Signed: Date:

Dr. Njihia Muranga

Lecturer,

School of Business, University of Nairobi

Signed: Date:

Mrs. Nancy Marika,

Lecturer,

School of Business, University of Nairobi

DEDICATION

This work is dedicated to my lovely wife, Lucy and my children, Alvin, Tina, Jade and Jayden, for their support during its preparation: your patience and encouragement as I stayed away for long, either in class or in the field in pursuit of academic excellence, was really touching.

ACKNOWLEDGEMENT

This work is as a result of the contribution of several people.

Would like to thank God for the wisdom and perseverance He has bestowed upon me during this research project, and indeed, throughout my life.

Secondly, I offer my sincere appreciation to my supervisors: Dr. Njihia Muranga and Mrs. Nancy Marika, who supported me throughout the project study, with their patience and knowledge whilst allowing me the independence to find my own footing in the research project. I appreciate every moment we spent discussing the project reports.

In a special way, I wish to thank the respondents who participated in this study. You made this possible.

Finally, I thank my family and friends. Without your support, I wouldn't have gotten this far.

I can't express enough gratitude to you all.

TABLE OF CONTENTS

DECLARATION	i
DEDICATION	ii
ACKNOWLEDGEMENT	iii
LISTS OF ABBREVIATIONS	vii
LISTS OF TABLES	viii
LISTS OF FIGURES	ix
ABSTRACT	x
CHAPTER 1 INTRODUCTION	1
1.1 Background of Study	1
1.1.1 Social Media Tools	1
1.1.2 Project Management Team at Safaricom Limited	2
1.1.3 Project Performance	3
1.1.4 Social Media Tools and Project Performance	3
1.2 Problem Statement	4
1.3 Project Objectives	5
CHAPTER 2 LITERATURE REVIEW	6
2.1 Introduction	6
2.2 Theoretical Background	6
2.2.1 Innovation Diffusion Theory	6
2.2.2 Task-Technology Fit	6
2.2.3 Work System Theory	7
2.3 Social Media Tools in Project Management	7
2.4 Project Management Performance Measures	8
2.5 Social Media Tools and Project Performance	8
2.6 Challenges for Project Managers	10

2.7	Literature Review and Research Gap.....	11
2.8	Conceptual Framework.....	11
CHAPTER 3 RESEARCH METHODOLOGY		13
3.1	Introduction.....	13
3.2	Research Design.....	13
3.3	Case Study Selection	13
3.4	Data Collection.....	14
3.4.1	Data Validation and Reliability	15
3.5	Data Analysis	15
CHAPTER 4 DATA ANALYSIS AND FINDINGS		16
4.1	Introduction.....	16
4.2	Response Rate.....	16
4.3	Demographic Information	16
4.3.1	Respondent Profile.....	16
4.3.2	Using Social Media Tools	17
4.3.3	Extent of use of social media tools in project management	20
4.3.4	Primary social media tools use in project management.....	21
4.3.5	Perception of social media tools use in project management.....	21
4.3.6	Adoption of social media tools at work.....	22
4.3.7	Social Media Tools Adoption Challenges	23
4.4	Discussion on Findings.....	24
CHAPTER 5 SUMMARY, CONCLUSION AND RECOMMENDATIONS		26
5.1	Introduction.....	26
5.2	Summary	26
5.3	Conclusion.....	27
5.4	Recommendations.....	27
5.5	Research Study Limitations.....	27

5.6 Areas for Further Study	28
References	29
Appendix 1	35

LISTS OF ABBREVIATIONS

CRM	Customer Relationship Management
IDT	Innovation and Diffusion Theory
IT	Information Technology
KRA	Kenya Revenue Authority
PMO	Project Management Office
PRINCE2	Projects In Controlled Environments, version 2
RSS	Really Simple Syndication
TTF	Task-technology Fit
WSF	Work system Framework
WSLC	Work System Lifecycle
WST	Work System theory

LISTS OF TABLES

Table 4.2:	Data Collection Response Rate	16
Table 4.3.1:	Respondent Profile	17
Table 4.3.2.1:	Social Media Tools extent of use in business	18
Table 4.3.2.2:	Social Media Tools extent of use in project management	19
Table 4.3.2.3:	Social media tools use for individuals	19
Table 4.3.3:	Extent of use of social media tools in project management	20

LISTS OF FIGURES

Figure 2.2.2: Task-Technology Fit	7
Figure 2.8: Conceptual Framework	12
Figure 4.3.4: Primary social media tools use in project management	21
Figure 4.3.5: Perception of social media tools use in project management	22
Figure 4.3.6: Adoption of social media tools at work in managing projects	23
Figure 4.3.7: Social Media Tools adoption challenges	24

ABSTRACT

In the current global and very competitive business environment, organizations must adapt, and fast to the changing needs and requirements of their customers to remain relevant. To achieve this, organizations must find innovative means of, not only communicating with their clients, but also find cost effective ways of communicating, collaborating and sharing knowledge. This is more critical in project management, a strategic tool used by seasoned organizations to come up with new products and services. To ensure the successful delivery of such projects, organizations, project teams and project managers are investing various social media tools to add value to their project management activities. Tools such as instant messaging, Wikis, collaboration tools, Video podcasts, blogs and social networking tools are already in use for project delivery. The research sought to characterize the use of these tools in project management. The tools used in project management, the extent of use of the tools and the challenges experienced in the implementation and use of the tools were researched on. To get the research population, purposive sampling was used and data gathered using a questionnaire. Qualitative analysis techniques, where thematic and content analysis, pattern matching and explanation building were used to analyze the collected data using constructed data categories. Thematic content analysis focused on pinpointing, examining, and recording patterns against the demographic data collected for the case study. An analysis was also carried out on the identified list of social media tools used in project management to uncover the underlying theme and patterns. To formulate the relationship between social media tools and project performance, pattern matching and explanation building was carried out with the view of uncovering any operational links worth mentioning.

The research found out that the social media tools employed, WhatsApp, Blogs and Video podcasts resulted in better communication, collaboration and knowledge sharing amongst the project management team, and hence improved project delivery. It was therefore concluded that social media tools use in project management contributed immensely in the performance of projects. Organization culture and wary by IT and senior management were found to be the biggest challenges in the adoption and use of social media tools in the organization and project management in particular.

Key Words

Social Media Tools, Project Management, Project Performance, Collaboration, Project Success.

CHAPTER 1 INTRODUCTION

1.1 Background of Study

Social media has revolutionized the way we communicate and collaborate, whether personally or within a business environment. Social media tools including blogging sites, Facebook, and Twitter are now common not only in the marketing arena, but other facets of the organization, where their usage or incorporation into the business strategy is dependent on the nature of the business and the strategic alignment to the business goals the tools are applied.

Project management as a profession has not been left behind, with project managers finding more innovative ways to ensure successful delivery of their projects using social media tools such as blogs, Wiki, and messaging tools. The social media tools use in project management can potentially lead to better collaboration, efficient communication, networking opportunities and increased project delivery, which may translate into better project performance given a good project implementation strategy.

The strategic nature of social media tools allows for knowledge sharing, collaboration and project visibility through efficient communication, critical requirements in project management. This translates to competitive advantage for organizations willing to implement these tools in their project delivery practices. In addition, he states that social media tools allow for the organization and deployment of (virtual) teams thus enhancing collaboration in project teams. The idea of a community and sharing of information and experiences translates into improved overall morale of the project team and may thus improve project delivery.

The objective of the research study is therefore to characterize the social media tools used in project management in Kenya, and in particular, Safaricom project management team. This is important for two reasons. First, it can be used to characterize the social media tools used to effectively manage projects. Secondly, the research will highlight the challenges faced in widespread acceptance of social media tools in project management, thus allowing for the design of related solutions to overcome the said challenges.

1.1.1 Social Media Tools

Social media are web-based communication resources that allow users to create, share, and exchange information. Boyd (2009) defines social media as a publication medium where users are active participants unlike traditional forms where users are passive. Social media tools

come in many forms such as blogs, forums, social networks, Chat apps, Microblogs, social gaming, and video and photo sharing sites. Blogs are online web pages used for sharing ideas and opinions with others, while collaboration tools are used for managing group activities. Instant messaging tools such as WhatsApp are used for online chatting, while microblogs are blogging tools on mobile devices. Webinars are online tools used to provide online seminars. Podcasts are audio files available online. Vodcasts are multimedia podcasts, while RSS Feeds are tools used for content distribution. Social networks are tools used for information exchange, and wikis are online collaboration tools used for knowledge management. Other social media tools for project management include YouTube, slideshare.net, Yammer, Wrike, Zoho, and LinkedIn. Yammer, is a social network service for private communication within organizations. YouTube is a video-sharing tool; slideshare.net is a professional content sharing community. Wrike is a social media tool used for project management and work collaboration. Zoho is a suite of online productivity tools, while LinkedIn is a business and employment-oriented social networking service. The above social media tools have one thing in common: they have varied features that are key to project management professionals, which include communication, collaboration and networking capabilities for the teams involved.

1.1.2 Project Management Team at Safaricom Limited

As of 2015, Safaricom limited had a permanent employee base of 4,192 (Safaricom, 2015). Safaricom employs young and dynamic staff, with 70 percent of the workforce in their 30s, while 16 percent in their 20s. The majority are permanent staff, with 51 percent male (Safaricom, 2015). The project management office (PMO) team has a total of 15 staff members that are tasked with the responsibility of ensuring that projects are delivered as per scope, on budget and on time. The PMO office at Safaricom manages projects in two main categories: customer focused and product/service focused teams. The project team is largely decentralized, reporting primarily to the business functional head. Being a commercial enterprise, the project team finds itself closer to the sales team, for the provision of project feasibility studies report and project lead times depending on availability of the project team. Apart from marketing related projects and new product and service launch projects, the project management office manages connectivity related projects for its customers (Internet, point to point connectivity) and collocation projects, where clients host their IT equipment and related resources at their international standard data centre for backup.

1.1.3 Project Performance

The current global economy has led to competitiveness in the business ecosystem, both in the local and global arena. With the increased competition, companies have been forced to change their strategies to remain competitive so as to retain their market share. To deliver business value, projects must be managed well (Bergeron, 2008) against the three major project constraints: scope, budget and time. A project is said to have been delivered successfully if it has been delivered as per the clients' scope, in good time and finally, within the specified budget. Generally, a successful project is one that deemed successful by the stakeholders. To achieve successful project delivery, project management requires certain tools, which include social media tools.

1.1.4 Social Media Tools and Project Performance

Project managers and by extension, project teams, are increasingly using social media tools in managing their projects due to their perceived added value in collaboration, communication and knowledge sharing capabilities. Merwe (2012) proposes that with proper consideration on security and confidentiality issues, social media tools can be used to enhance project delivery. Mark (2006) suggests changing project management from being an instrumental process, to being a social process, given that a project is more than a production process, but a social interaction among people that results in proved project performance.

In her research, Monica (2013) concluded that Project Management Information Systems (PMIS) help in the achievement of project success. Given that social media tools are a form of IT applications, then increased effectiveness in project delivery is anticipated, a view supported by Khalifa (2010). In a related study by Papacharissi (2009) he corroborates the view that social media tools are indeed a good way for a team to interact and can thus be considered for use in project management.

Project constraints include delivery of a project per scope, on time and within budget. Through constant and effective communication with stakeholders, social media tools help project managers quickly and efficiently engage stakeholders thus ensuring the project is on scope as per stakeholder requirements. Such engagement will lead to quick resolution of project issues and hence provide for timely delivery of the project.

1.2 Problem Statement

Social media tools are increasingly being used in project management, either as an alternative to existing enterprise-wide tools such as Microsoft SharePoint and Microsoft Project, or to supplement these legacy systems primarily for collaboration, communication and knowledge sharing. Social media tools allow for knowledge sharing and project visibility, key contributors to project performance. With social media tools, dispersed teams can work seamlessly together despite the distance barrier. In addition, the tools allow project managers to achieve a 24-hour workday that requires real-time information delivery to all project stakeholders for task closure, status update or quickly adapt to changing project conditions, favorable or otherwise. In her research, Harrin (2011) asserts that cost savings on meetings is the largest financial benefit gained through using social media tools. Additionally, social media can be used to capture and store organizational best practices and knowledge (Schettini, 2011).

Safaricom Ltd. is a communication service provider, well known for its Mpesa money transfer platform. The company offers voice and data services, financial services and other enterprise services, not only in Kenya, but the region to a whole range of businesses and service subscribers, both private and government. The company has achieved the above largely through its project management strategy, which is either customer focused or product/service focused. This study sought to not only understand which social media tools have been used to achieve such stellar performance, but also how these tools have been used in project management.

The main challenge that project managers face in adopting social media tools in project management include company culture, that is at times too rigid to embrace new technology and innovative ways of achieving its core objectives. Without appropriate policies and guidelines, the use of such tools in project management might prove to be a mine field for inexperienced project managers. In addition, the technology itself is a challenge, more so to the IT teams who are wary of the security implications that new technology present. Finally the lack of senior management involvement and support has often contributed to the slow adoption of such tools, not only in project management practices, but also in the entire organization. The research question therefore is; what social media tools are used in project management in Safaricom, and whether they result into project performance efficiency.

1.3 Project Objectives

This research paper sought to characterize social media tools employed in project management by the project management team at Safaricom limited. The research intended to find out the extent to which social media tools have been employed in the management of projects, and further determine the impact of the tools in the performance of projects. In addition, the paper sort to determine and ascertain the challenges experienced in using social media tools in project management.

CHAPTER 2 LITERATURE REVIEW

2.1 Introduction

In this chapter, we reviewed relevant literature to the study, including theories relevant to the study area, such as technological innovation. It then dwelt on the empirical studies that discussed the link between technological innovation and performance of projects.

2.2 Theoretical Background

Innovation and Diffusion Theory – IDT (Benbasat, 1996), Task-Technology Fit – TTF (Goodhue, 1995), and Work Systems Theory – WST (Alter, 2013) are the Information System (IS) theoretical models used to explain the adoption of social media tools in project management.

2.2.1 Innovation Diffusion Theory

Innovation diffusion theory (IDT) is a model applied to define elements that may influence the acceptance of new technology (Nor, Pearson, & Ahmad, 2010). Accordingly, Rogers (1996) suggested five characteristics that affect the acceptance of new technology, including: *relative advantage*, *compatibility*, *complexity*, and *trialability* and *observability*. Relative advantage is the degree to which the newly adopted innovation is seen to be a lot more valuable than its predecessor. Organizations adopt new technologies because of the relative advantage such innovations provide organizations in the form of competitive advantage over those that are not using the new technology. The diffusion theory is relevant to an organization as it provides a framework for explaining the reason why organizations adopt technical innovations.

2.2.2 Task-Technology Fit

Task-Technology Fit (TTF) is model that is used to define the degree to which technology assists an individual to perform their specified task (Goodhue, 1995). The model explains that if the capabilities of the technology match the task at hand, then it is more likely the technology will be adopted (Goodhue, 1995). This implies that the technology must be used for the technology to have a positive impact on user performance, and for the technology to be used, there must be a good fit between the task at hand and the technology that supports it (Goodhue, 1995). The task-technology theory, and (system) utilization, is relevant in predicting user-job performance and effectiveness in using a specified system under investigation. Figure 2.2.2: Task-Technology Fit Model.

Figure 2.2.2: Task-Technology Fit Model

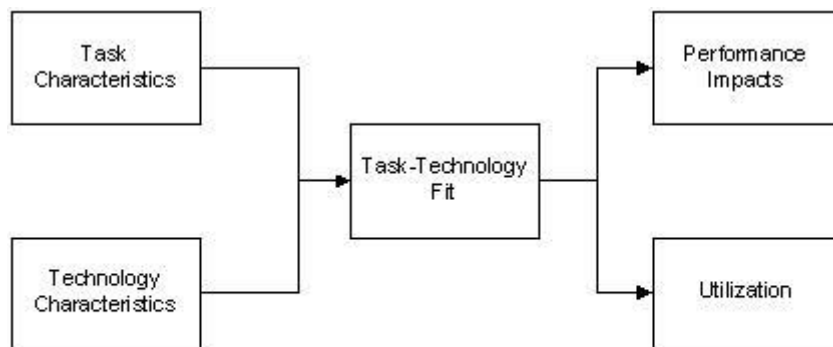

Source: Goodhue and Thompson, (1995)

Source: Goodhue and Thompson (1995)

2.2.3 Work System Theory

Work system theory (WST) consists of three components, namely, the work system, the work system framework and the work system lifecycle. A work system is a system in which participants perform work using technology, information and other resources to produce outputs for customers (Alter, 2013). The work system framework is a static view, while the work system lifecycle model is a dynamic view of how the work system changes over time due to planned and unplanned change requests (Alter, 2013). Examples of work systems include an information system through its processes and activities, it's able to process information. A project is another example of a work system that comes into existence to produce a specific product/service and then ceases to exist. Other examples include, a service system, a supply chain system, and an e-commerce website.

The work system theory (WST) is relevant as it's able to explain the integration between factors involved in the process of value creation in a particular work system, in this case a project, in order to promote sustainability and lasting performance. This calls for (project) managers to engage in adaptive and proactive behavior to ensure the performance of the system (project) they are charged with.

2.3 Social Media Tools in Project Management

The most widely used social media tools in project management are LinkedIn and instant messaging tools (Harrin, 2011). Podcasts and webinars are good as training tools, especially for project managers who want to sharpen their project management skills. During project

delivery, tools such as Wiki, blogs and RSS are most appropriate (Merwe, 2012). Blogs are good for sharing project information to project virtual teams, while Wikis and RSS are good for subscribing to feeds relevant to a specific project. Instant messaging tools, such WhatsApp are good for real-time communication due to their instant delivery of messages. Other tools available for project managers include, *Yammer*, *Wrike*, *Zoho* and *Msurvey*. *Msurvey* is a social media tool for assessing market penetration of a product/service after a project launch.

2.4 Project Management Performance Measures

The traditional definition of a successful project is one that has been delivered as per the budget, in time and as per the intended scope. Amongst the project success definition frameworks brought forward include the Logical Framework Model (Baccarini, 1999) and the Multidimensional Universal Framework (Aaron J. Shenhar, 1997).

In his research, Bacarrani (1999) uses the logical framework model to define project success. Project management success, which includes output and input project objectives, and project product success, which includes goals and purposed project objectives, form the two arms of project success defined by Baccarini (1999).

Aaron(1997) proposes a multidimensional universal framework of defining project success and suggests that management conceive project success as using four distinct dimensions, namely *project efficiency* (short-term, looks at how efficiently the project was managed, within the traditional confines of project success), *impact on customer* (the primary objective of the project is the impact is has on customer requirements and real needs), *business success* (profit making or otherwise), *preparing for the future* (lessons learnt and how the organizations adapts to plan for the future)

The two approaches overlap but the underlying definition of project success is when the project clients are happy with the results of the project. For this research paper, we are to employ the traditional definition to explain the relationship between project success and social media tools.

2.5 Social Media Tools and Project Performance

Klynstra (2012) explains in his study how social media can help project managers address communication related issues in project management to ensure effective communication, and by extension better project performance. Twitter comes in tops with real-time delivery of news and information, with indexing of topics by use of tags. To build project communities,

Facebook, Yammer or Google+ tools are suggested. Facebook brings a timeline-like project information sharing capabilities, great for tracking project activities in a timeline manner. For an iterative project methodology, the timeline can reveal a wealth of information during review, thus improving the outcome of the project phase in question. Yammer provides similar functionality but it focuses on the company. For big projects, where a lot of information is shared and involves more than normal collaboration, Yammer is preferred. To deliver engaging project materials, tools such as YouTube and Podcasts are suggested. These are particularly useful for distributed teams where personal connections can be created despite the distance. In a study by Harrin (2011) she described the different social media tools that can be employed in project management and provided for alternative approaches to project communication, collaboration and networking opportunities, critical for efficient project delivery. In her article, Linkyvd Merwe (2012) states that blogs as social media tools can be used to distribute project information to virtual teams, while Wiki's and Really Simple Syndication (RSS) can be used to subscribe to project feeds or to information that will help develop project managers. She concludes by saying, with proper strategies and policies in place, project managers should adopt appropriate social media tools, which will enhance project delivery. Project managers can deliver projects successfully if they communicate effectively with their stakeholders (Egg Van, 2013).

Social media tools can assist project managers share knowledge and have better project visibility. Social media tools can also assist the project manager identify, organize and deploy project teams. Social media enhances collaboration across project teams and with remote users. Additionally, social media tools provide real-time information to project teams, which enhances the ability of project managers to make quick decisions given the direction the project is taking and availability of information. Finally, social media tools help reduce traveling costs and assists document best practices and project learnings (Merwe, 2012). Google Docs, Wiki, and Blogs, are useful for collaboration work, and sharing knowledge and information (Egg Van, 2013). Yammer is good for sharing information and for forming tighter teamwork among employees. Feeds recollect, share and maintain information. In situations where questions-and-answer-like communication is desirable, Formspring is good. Podcasts are good for audio recordings, such as audio training sessions for project managers and project teams.

2.6 Challenges for Project Managers

From the traditional definition of project success, where a project is deemed successful upon delivery as per plan, then a project that fails is one that fails to meet the time, budget and quality targets. Blanas (2011) points out that high levels of team collaboration may not correlate with team performance given that task characteristics – task novelty, complexity and uncertainty - may influence the relationship of team members. Given that social networks are cross-functional and non-hierarchical, the collaborative and non-hierarchical management of projects distributed across company borders or into several organizations, poses a challenge for project managers.

Junquiera (2010) states that projects can and should benefit from the opportunities for interaction provided by social media (tools). This free dynamic exchange of project ideas will serve the project's interest and project managers should embrace it. However, he cautions and states that the rising technological awareness has potential for misuse, unless standards are followed. Gago (2012) discusses major challenges project managers face when dealing with enterprise level social networks such as security, structural rigidity, low customer involvement, stifling creativity and productivity concerns. Speculations are rife that while social media tools have addressed the project team, they have been less helpful to the project manager. Very little focus has been on the methods and tools to support the project manager's decision making (Jansson & Riikonen, 2009).

Other quarters argue that social media tools are not as helpful to project manager especially in managing core project management processes, despite enabling participation and automation (Trilog Group, 2012). The ProjectPlace (2012) paper warns that unstructured and uncontrolled use of social networking could lead to anyone starting to use them freely, thereby bypassing regulations put in place by the organization. The paper further explains that such social media platforms are better suited for public relations and marketing channels and hence cannot be applied to other business areas. In some cases, it has been advised that implementing social media tools in project management is not just a technology challenge but also a cultural too (Merwe, 2012). Harrin (2016) states that without senior management involvement, good business case, IT concerns regarding security issues, and blurred line between official and personal data online as barriers to the realization of benefits of social media and collaboration tools.

2.7 Literature Review and Research Gap

The lack of guidelines to guide project managers on how to implement and use social media tools in project management to achieve better project delivery was cited by Herbert and Nory (2012). This implies that such tools are being used under test-case environments. More research needs to be carried out to determine the effect on the implementation of social media tools in project management against gender and culture as moderators (Khalifa, 2010). To improve the practice of project management, it is suggested that more research is required to determine the models to be used to setup appropriate social media networks (Wynne, 2015). In her research, Harrin (2011) sought to determine whether social media tools were essential to project managers. Documented best practices are required to guide project management practitioners in managing projects by use of social media tools (Silvius, 2016). In his research on globally distributed teams, Ilan (2005) suggested for further research on knowledge sharing, collaboration and social ties amongst teams working on global projects.

2.8 Conceptual Framework

The research sought to characterize the social media tools used in project management and how they affect the dynamics of the project team to result in better project delivery.

Figure 2.8: Conceptual Framework

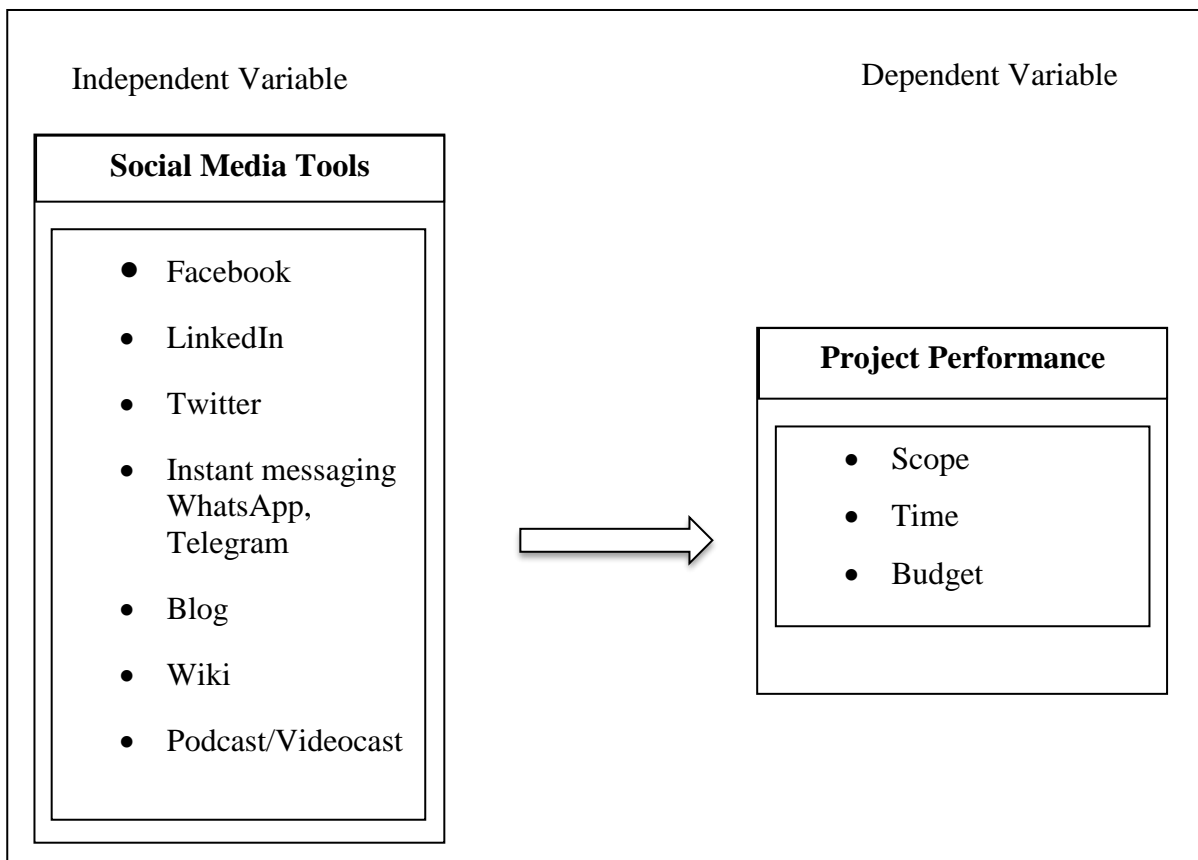

Source: Kizito (2016)

From the above framework, it was concluded that social media tools play a greater role in ensuring better collaboration, communication, knowledge sharing and networking opportunities amongst the varied project stakeholders, such that the project scope is better managed, project budgets are adhered to and project schedules are not overrun. Through the use of such tools as WhatsApp, Blogs and Video podcasts, project delivery was enhanced, through real-time communication of project information, tighter collaboration of project teams and better sharing of project knowledge amongst project stakeholders. Figure 2.8: Conceptual Framework.

CHAPTER 3 RESEARCH METHODOLOGY

3.1 Introduction

The methodology of study is discussed in this chapter. The case study approach was chosen to investigate the dynamics of social media tools in improving project performance in the project management team at Safaricom limited. First, the research plan is discussed, then the sampling procedure, the means of data collection, and finally, the data analysis method.

3.2 Research Design

A plan on how data will be collected and investigated for relevance is defined as the research design (Babbie, 2013). It is the plan for getting from the research questions and objectives to the research conclusions (Rowley, 2002).

Amongst the research questions answered included how social media tools are contributing to better project performance; what challenges are faced by the project management office team in using social media tools in project management, and finally, what factors influence the project management team in their decision to use the stated social media tools in project management. This research sort to define and ascertain the specific social media tools used in project management. In addition, how social media tools affect project management team's communication and collaboration in such a way that it improves the project's performance levels. The analysis unit for this study was the project management team within Safaricom limited. Pattern matching and explanation building were used to link the collected data to the above mentioned propositions and to determine the casual links, if any, between social media tools and project performance. Analytical generalization and internal validity were used as the criteria for interpreting the study findings.

3.3 Case Study Selection

The technical project management office team at Safaricom comprises of 15 team members, of which 8 are project managers, 4 project coordinators, 2 project analysts and one project administrator. Other project managers and the related project teams came from the given business unit as owners of the project being implemented. The sample population was selected using purposive sampling to determine the experts in the area being studied. The survey ran for a month starting October 2016. Respondents were invited to participate through email.

3.4 Data Collection

This study sought to characterize the social media tools used by the project management team of Safaricom limited in project management. In addition, it sought to determine the impact of the application of these tools in project performance and the related challenges faced in their adoption in project management. This study makes several speculations, such as social media tools application in project management affects project's team communication and collaboration in such a way that it improves the project's performance levels. It also results in better stakeholders' involvement, which translates into improved project teams' dynamics in areas such as managing project scope, budgets and scheduling.

The data collection instruments used included questionnaires and interviews. Questionnaires for project managers and team members were provided addressing aspects like specific social media tools used in the project for communication, collaboration, building relationships and trust. The research instruments were administered to a sample population of 22 potential respondents.

Respondents were asked to select from the list provided the social media tools they commonly use in project management. These tools were listed as Facebook, LinkedIn, Twitter, Instant messaging, Blogs, Wikis, Podcasts, Video casts, *Yammer*, *Wrike* and *Zoho*. They were further required to state whether the usage was high, medium, low or not applicable. Additionally, respondents were required to demonstrate to what extent social media tools were important to them. Amongst the available options included communication efficiency, collaboration with team members, collaboration with client, networking, cost saving and knowledge sharing. Selection of multiple options was accepted. The respondents were also required to match the available social media tools to the type of project at hand and also the type of project deliverable to gauge on whether the tools used vary from one project (type) or project product (type) to the other.

In addition, respondents were asked to bring out the perceived benefits of using social media tools in project management by agreeing or disagreeing to provided statements. Each of the statements was measured on a scale varying from 5 (strongly agree) to 1 (strongly disagree) Likert scale. Finally, respondents were to bring out the challenges they face in using social media tools in project management by agreeing or disagreeing to provided statements. Each of the statements was measured on a scale varying from 5 (strongly agree) to 1 (strongly disagree).

Each of the questionnaire section had an open-ended question part that was used for the telephone interview.

3.4.1 Data Validation and Reliability

The data collection instruments (questionnaire and interviews) were verified by subjecting them to a pilot run through experienced project managers and project implementers, who agreed that the tools in use were appropriate in measuring the research objectives.

3.5 Data Analysis

This section of the study involved examining, tabulating and categorizing the collected evidence to assess whether the evidence supports the initial study propositions or not (Yin, 1994). Qualitative analysis techniques, where thematic and content analysis, pattern matching and explanation building were used to analyze the collected data using constructed data categories. Thematic content analysis focused on pinpointing, examining, and recording patterns against the demographic data collected for the case study. The generated list of social media tools used in project management was analyzed to determine the underlying theme. To formulate the link between project performance and social media tools, pattern matching and explanation building was carried out with the view of uncovering any operational links worth mentioning.

CHAPTER 4 DATA ANALYSIS AND FINDINGS

4.1 Introduction

The study sought to characterize the social media tools used by the project management team of Safaricom limited in project management. Data was gathered using interviews and questionnaires. The research findings are presented based on the objectives of the study.

4.2 Response Rate

Out of the 22 questionnaires distributed, 17 were duly filled and returned, representing a response rate of 77%. In addition, two telephone interviews were carried out with experienced project managers in an attempt to understand how they manage projects using social media tools. A good response rate should be 50% or more (Mugenda, 2003). Therefore, this response rate is considered to be adequate in forming conclusions and generalization of the population under study. Table 4.2 below.

Table 4.2: Data Collection Response Rate

Response	Frequency	Percent
Returned	17	77%
Unreturned	5	23%
Total	22	100%

Source: Research Findings

4.3 Demographic Information

This section is arranged based on the objectives of the study.

4.3.1 Respondent Profile

The respondents were broadly split between men and women. As per Table 4.3.1, 60% of the respondents can be found in the 36 – 40 age group. Most of the respondents of the research study are very young in the field of project management: between 1 to 3 years. Additionally, most respondents were part of a project team and not necessarily project managers, possibly due to the fact that there was a project management office responsible for the management and implementation of projects, thus fewer project managers. It is also interesting to note that a good percentage of the respondents are new to using social media tools in project management, with 80% having used them for three or so years. The seasoned project managers have used them for a longer period.

Table 4.3.1: Respondent Profile

Gender	Percent
Male	77%
Female	23%
Age	
< 25 years	20%
26 – 30 years	20%
36 – 40 years	60%
Experience	
1 – 3 years	40%
4 – 5 years	20%
6 – 10 years	20%
10 > years	20%
Project Role	
Project Management	40%
Program Management	20%
Project/Program Support	80%
Change Management	40%
Tools Usage Period	
1 – 3 years	80%
4 – 6 years	20%

Source: Research Findings

4.3.2 Using Social Media Tools

The component was measured the respondents, level of usage of the varied social media tools in a business, project management and personal setting.

4.3.2.1 Business Use

To measure this component, the respondents were to indicate the level of use of the provided social media tools in the business setting. Table 4.3.2.1 indicates that all the respondents indicated a high usage of instant messaging tools, such as WhatsApp in business communication. The reason for this is because WhatsApp communication is instant and replies are easy to forth come. This trend is repeated when analyzing social media tools usage in project work and personal use. 60% of the respondents indicated a low Facebook social media tool use in business. The implication of this is that there were internal efforts to foster communities of common interests for business purposes. 50% of the respondents indicated an average usage of Blogs in a business setup. This implies that 50% of the respondents used blogs

to share ideas on the varied business challenges and opportunities faced by their peers, hence a conscious effort to improve on the quality of deliverables in their business areas.

Table 4.3.2.1: Social Media Tools extent of use in business

Social Media Tool	High	Medium	Low	Not Applicable
Facebook	40%	0%	60%	0%
LinkedIn	25%	25%	25%	25%
Twitter	25%	25%	25%	25%
Instant Messaging (e.g. WhatsApp, Telegram)	100%	0%	0%	0%
Blog	25%	50%	25%	0%
Wiki	25%	0%	50%	25%
Podcast	0%	0%	33%	67%
Video podcast	0%	50%	0%	50%
Yammer	0%	0%	10%	20%
Wrike	0%	0%	10%	20%
Zoho	0%	0%	10%	20%

Source: Research Findings

4.3.2.2 Project Management

Respondents were to indicate the level of usage of the provided social media tools in the project setting. Table 4.3.2.2 indicates that all the respondents indicated a high usage of instant messaging tools, such as WhatsApp in project management. The reason for this is because WhatsApp is very practical in getting teams to work together. 50 % of the respondents indicated an average use of Blogs and video podcasts in the project management setting. This is in line with the nature of the tools: Blogs provide for sharing of experiences and ideas given a specified field of interest, while Video podcasts are good in providing training sessions. The implication for this is that there is a concerted effort by the respondents not only to improve on their project management skills through training, but also to consult with their peers in getting answers to project management challenges. This in turn translates into better project delivery and performance in general. 50% of the respondents had no practical experience in social media tools use in project management. This implies that very little effort has been put in place to forge communities of interest in Facebook regarding social media.

Table 4.3.2.2: Social Media Tools extent of use in project management

Social Media Tool	High	Medium	Low	Not Applicable
Facebook	25%	0%	25%	50%
LinkedIn	0%	10%	50%	0%
Twitter	25%	25%	50%	0%
Instant Messaging (e.g. WhatsApp, Telegram)	100%	0%	0%	0%
Blog	0%	50%	50%	0%
Wiki	0%	25%	50%	25%
Podcast	0%	0%	75%	25%
Video podcast	0%	50%	25%	25%
Yammer	0%	0%	75%	25%
Wrike	0%	0%	75%	25%
Zoho	0%	0%	75%	25%

Source: Research Findings

4.3.2.3 Personal use

Respondents were to indicate the level of usage of the various social media tools in a personal setting. Table 4.3.2.3 indicates that 50% of the respondents use Facebook for personal use, which is higher than WhatsApp at only 30%. It is interesting to note here that there is a very low usage of most of the provided social media tools, indicating that most of the respondents were, not only familiar with all the tools under test, but were using them in other areas of their personal lives. This implies that given a chance, they would easily make use of them in either the project management setting or business setting.

Table 4.3.2.3: Social media tools use for individuals

Social Media Tools	High	Medium	Low	Not Applicable
Facebook	50%	25%	0%	0%
LinkedIn	0%	0%	50%	0%
Twitter	25%	0%	50%	0%
Instant Messaging (e.g. WhatsApp, Telegram)	30%	0%	0%	0%
Blog	0%	25%	50%	0%
Wiki	0%	25%	50%	0%
Podcast	0%	0%	25%	25%
Video podcast	0%	25%	0%	50%
Yammer	0%	0%	25%	25%
Wrike	0%	0%	25%	25%
Zoho	0%	0%	25%	25%

Source: Research Findings

4.3.3 Extent of use of social media tools in project management

Here the respondents were asked to select the social media tool used in a given project type and project product type in project management. For a given project type and project product type in project management, respondents were to indicate the social media tools used. Results in Figure 4.3.3 indicate that WhatsApp is used in all the project management activities irrespective of the project type and/or project product type. The implication of these is that WhatsApp is proving to be a versatile tool for project managers and their teams. Blogs, Wikis, and Facebook social media tools also featured as per the respondents, indicating that there are certain variations that are worth investigating.

Table 4.3.3: Extent of use of social media tools in project management

Project Type/Project Product Type	Facebook	Twitter	Instant Messaging, e.g. WhatsApp	Blog	Wiki	Yammer	Wrike	Zoho	Not Applicable
Administrative Project (example, installing a new accounting system or Customer Relationship Management system (CRM), confirming project schedule)	25%	0%	50%	25%	0%	0%	0%	0%	0%
Construction Project (example, set up of new data center or base station)	0%	0%	100%	0%	0%	0%	0%	0%	0%
Software Development Project (example, a mobile/online app)	0%	25%	50%	0%	25%	0%	0%	0%	0%
Design of Plans (example, architectural or engineering plans, e.g. new network roll-out)	0%	0%	25%	25%	25%	0%	0%	0%	25%
Equipment or System Installation (example, Internet installation or data center collocation)	0%	0%	75%	0%	0%	0%	0%	0%	25%
Event or Relocation (example, marketing or moving into a new building)	75%	0%	25%	0%	0%	0%	0%	0%	0%
Maintenance of Process Industries (example, Infrastructure or service upgrade)	25%	0%	50%	0%	25%	0%	0%	0%	0%
New Product Development (example, a new product or service)	0%	75%	25%	0%	0%	0%	0%	0%	0%
Research (example, a feasibility study, market research)	25%	0%	25%	0%	25%	0%	0%	0%	25%

Source: Research Findings

4.3.4 Primary social media tools use in project management

The component was measured by asking the respondents to select any one or all of the indicated extent of usage of social media tools in project management. Here, respondents were to indicate the extent of social media tools use in project management. Results in Figure 4.3.4 indicate that communication efficiency, internal team collaboration and knowledge sharing scored highly in relation to why social media tools are used in project management. All respondents had similar trends regarding the reasons of using social media tools in project management, meaning they shared similar perceptions in the use of the tools in project management.

Figure 4.3.4: Primary social media tools use in project management

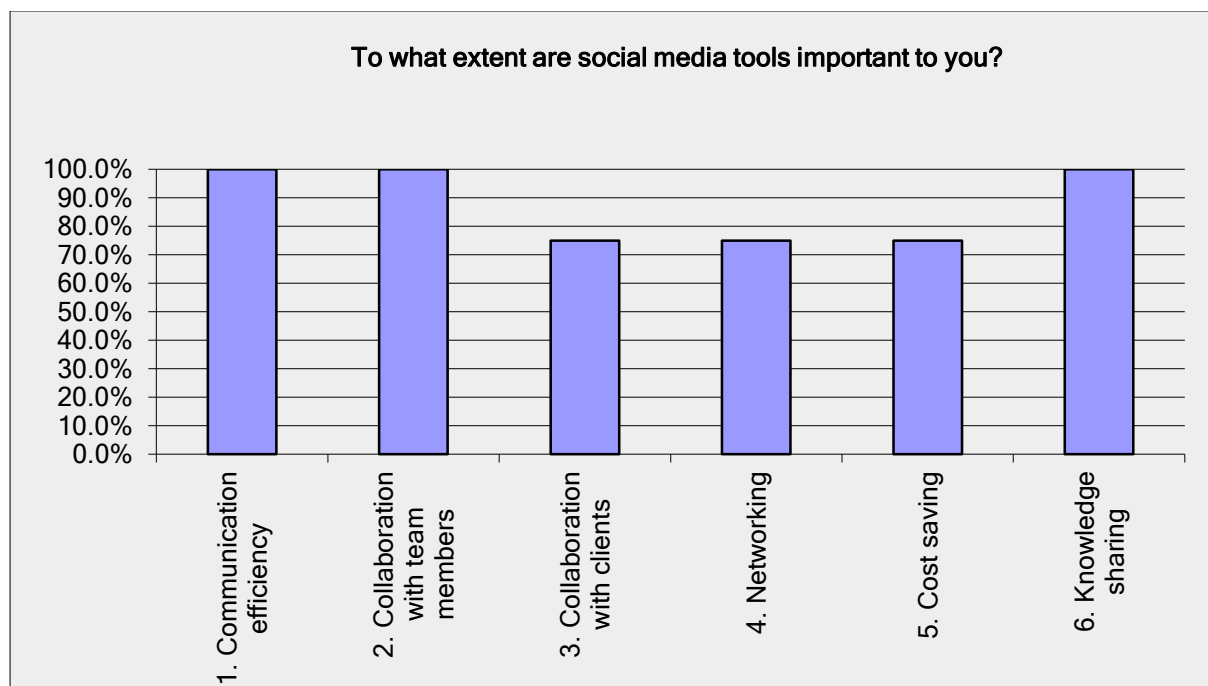

Source: Research Findings

4.3.5 Perception of social media tools use in project management

The component was measured by determining five items which were rated on the Likert scale. The respondents were unanimous in stating that there were relative advantages in using social media tools in project management. Figure 4.3.5 indicates that best practice communities came in second at 95% implying that collaboration was seen as an essential aspect in project management brought about by using social media tools. 90% of the respondents agreed that they have more fun managing projects using social media, implying that it is something they would look forward, thus increasing the chances of the success of the project at hand.

Additionally, 85% of the respondents agreed that social media tools exposed them to new ways of managing projects. Such a perception would result in process improvement hence better project delivery.

Figure 4.3.5: Perception of social media tools use in project management

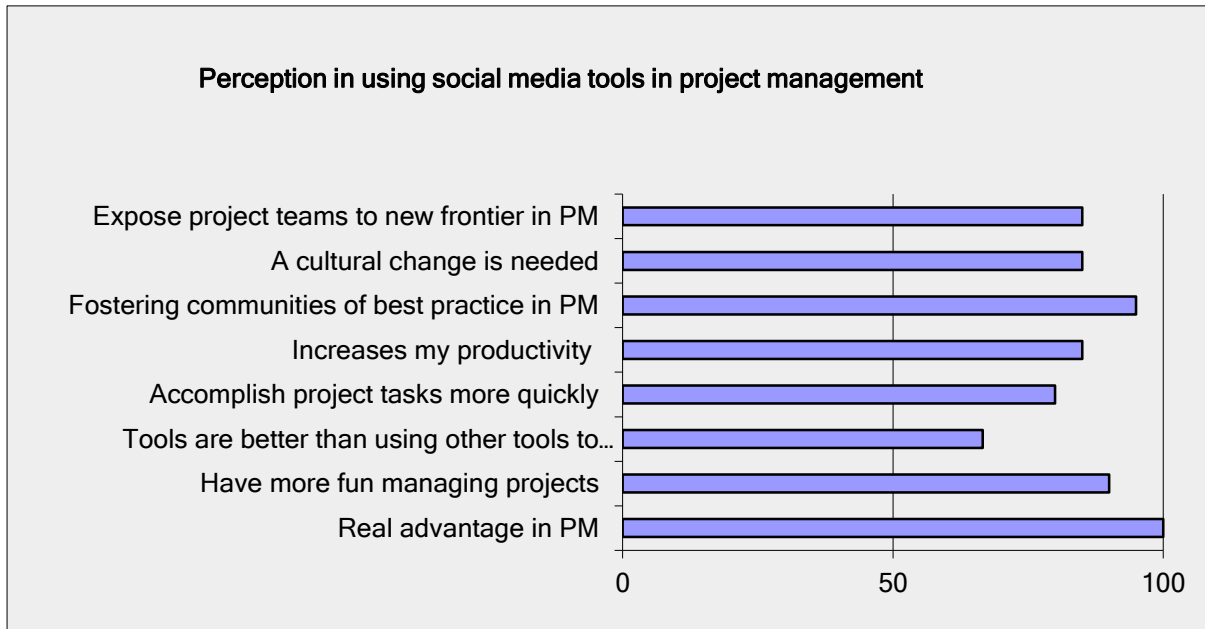

Source: Research Findings

4.3.6 Adoption of social media tools at work

The component was measured by determining whether they agreed with the stated adoption statement or not. The varied response indicated that despite the widespread use of the tools, such adoption was not centrally sanctioned by the organization. From Figure 4.3.6, it was interesting to note that the organization had not curtailed their use either. 70% of the respondents indicated that social media tools had not only been adopted in project management, but the entire organization. 50% of the respondents indicated that the tools had been adopted but not officially, implying that there were no clear guidelines on the use of such tools, but their use had been accepted given the related advantage in the working place. In addition, 50% of the respondents indicated that the tools had been adopted across the organization in managing projects. This percentage implied that the tools had been adopted across the organization, not only in managing projects, but also in managing other business functions/activities, such as marketing, internal collaboration and administration.

Figure 4.3.6: Adoption of social media tools at work in managing projects

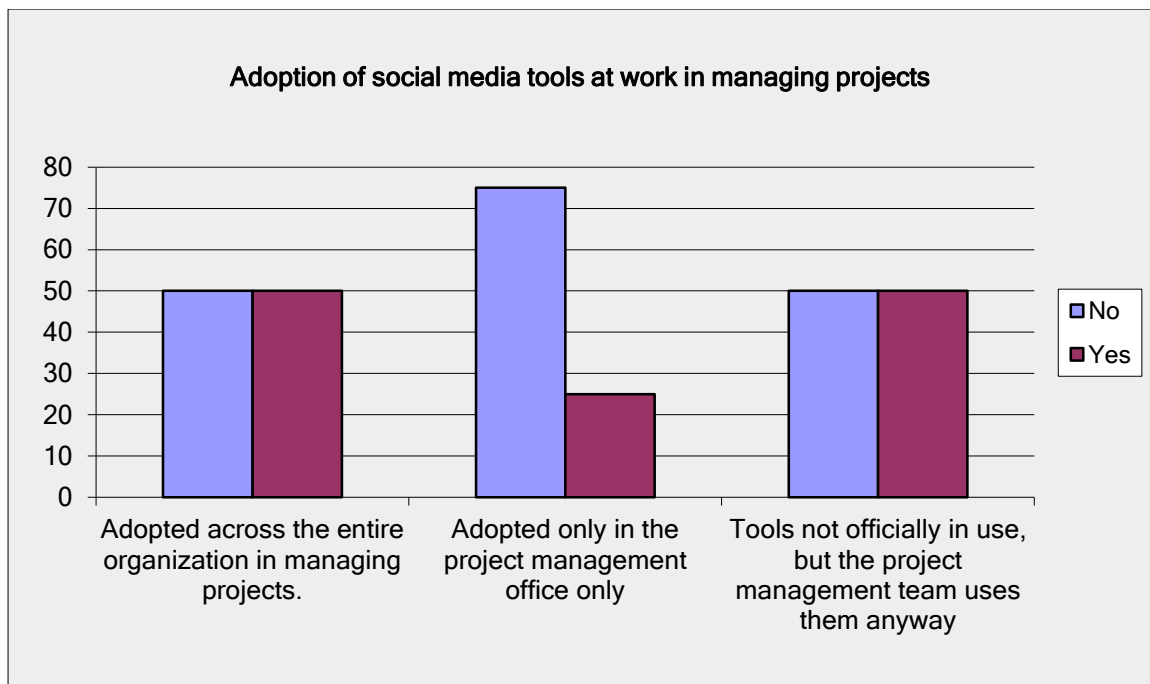

Source: Research Findings

4.3.7 Social Media Tools Adoption Challenges

The component was measured by determining five items which were rated as either, strongly agree, agree, neutral, disagree or strongly disagree of the Likert scale. The respondents were asked to respond to provided statements regarding the challenges involved in adopting social media tools in project management. All respondents disagreed with the notion that social media tools are just another technology and has no effect on new ways of working. This implies that, social media tools use in project management has revolutionized the way they were managing projects which had a bearing on project performance. From Figure 4.3.7, 90% of the respondents indicated that their IT department and leaders were wary of the new technology, possibly due to the lack of policy guidelines from the management on the use of such tools and also the related security implications, especially to the IT team. 85% of the respondents agreed that company culture was the biggest contributor to resistant to change in using the new tools in project management. This implied that a positive company culture would go a long way in ensuring the adoption of social media tools not only in project management, but also in other facets of managing the business. Only 20% of the respondents felt it is not necessary to have executive support in adopting social media tools in project management. This is an interesting perception given the autonomy with which these tools are available for use. This implies that

the executive is better off providing policy guidelines rather than fight employees in using such tools.

Figure 4.3.7: Social Media Tools adoption challenges

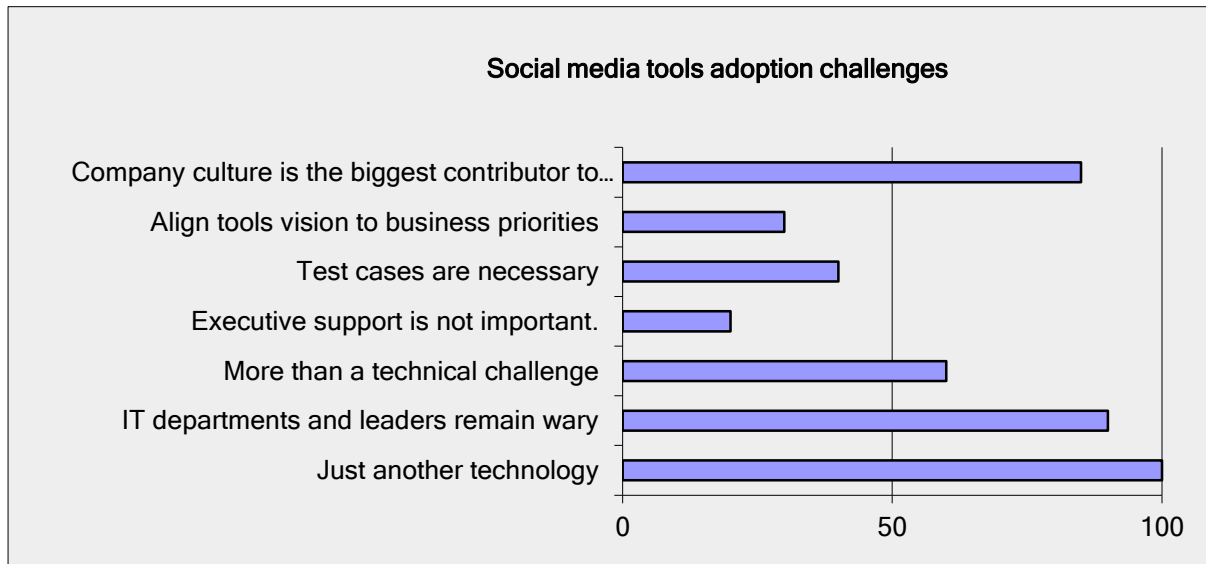

Source: Research Findings

4.4 Discussion on Findings

This discussion is informed by the research study objectives. The findings indicate that three social media tools are prominently used by the project management team at Safaricom Ltd. These are WhatsApp, Blogs and Video podcasts, Table 4.3.2.1, compared to the ten listed by Harrin (2011). WhatsApp comes at 100% high usage by all the respondents as it is instant and replies are quick and direct. It also has support for messaging of images and videos, both of which are important in deriving feedback, more so in the project management setting. Harrin (2011) in her research, concluded that the most widely used (social media) tools are LinkedIn and instant messaging (chat) within the context of the business settings. In addition, WhatsApp is very practical in getting teams to work together, Blogs are good for sharing ideas amongst teams of common interests. This is in line with the project team working on a certain task and shared experiences would greatly improve on the quality of project.

With applications such as Blogs, Twitter, Facebook, project teams are better placed at dissemination of information and carrying out research. These tools carry more content and through sharing can reach a wide net of people. They are good also for gauging the sentiments of stakeholders in projects, especially when testing a new product or making changes to

existing products and services. This effects the delivery of a project positively. The respondents also pointed at using Video podcasts in project management. Video podcasts are good at offering online training sessions. For the project management team, this meant that they are more than willing to go an extra mile to improve on their project management skills, this in turn would translate into better project delivery and performance.

In regards to extent of social media tools use in project management, communication efficiency, collaboration with teammates and knowledge sharing were indicated as the reason for using the tools in project management (Figure 4.3.4). This is in line with Harrin (2011) findings and Klynstra (2012) where the primary benefits of using social media tools in project was documented. This brings a wealth of advantages to project teams. For instance, with collaboration of global teams, project managers can adapt learnings from other markets and localize them for effectiveness, thus improving the performance of projects. Communication is key to successful delivery of a project (Egg Van, 2013).

In regards to the challenges experienced, 100% disagreed with the assertion that social media tools are just another technology and not something that enables new ways of working (Figure 4.3.7). Klynstra (2012) agrees with this trend when he warns project managers that change is in the air. 90% of the respondents agreed that IT departments and the leadership are wary of the new technological trends. Harrin (2016) agrees with this when she asserts that the wariness of the adoption of the tools in project management is partly due to a lack of overall strategy and senior management involvement. 85% of the respondents indicated that company culture is the biggest contributor to resistance to change in using social media tools in project management. This is in line with Linkyvd Merwe (2012) who proposes that a cultural change is also needed for a successful social initiative.

As a way to mitigate against the mentioned challenges, project managers are advised to phase out the roll out of new innovative tools. Some social media tools require change management strategies, some require to be phased for easier adoption, whilst others require open testing across a wide network of users before adoption into law.

CHAPTER 5 SUMMARY, CONCLUSION AND RECOMMENDATIONS

5.1 Introduction

The summary of key findings, conclusions and recommendations of the study are provided in this chapter. These are aligned to the specific objectives of the research study.

5.2 Summary

The current study aimed at characterizing the social media tools employed at Safaricom limited in the management of projects. From the study findings, several tools have been used with the express aim of improving communication, collaboration and knowledge sharing amongst the project management team. These tools include WhatsApp, Blogs and Video podcasts amongst others. WhatsApp was lauded for quick information relay to working teams requiring immediate attention. Blogs, Twitter, Facebook social media tools were in use for dissemination of information and research. All these were in place to ensure better quality in project performance.

The project also sought to establish the impact of application of social media tools in project management. Results show that the social media tools in place improved communication, collaboration with teammates and encouraged knowledge sharing. This plied real time communication capabilities where responses were required immediately. Knowledge sharing also allowed teams to adopt accordingly as the project progressed to mitigate against raised problems and/or take advantage of the available opportunities to ensure the delivery of the project. Other benefits of using social media tools in project management include savings on roll out and implementation costs as various projects can share communication platforms. In addition, social media tools greatly enhanced collaboration of teams. This allowed for incorporate multi-disciplinary teams from various departments thus cutting out departmental approval to make decisions. Such removal of red tape ensures high turn-around of project tasks/activities which in turn improves on project outcome.

The research also sought to define the obstacles to overcome in implementing social media tools in project management. From the results, it was noted that IT departments and senior management remained wary of the new ways of working. In addition, company culture was noted as the biggest contributor to resistance to change in using the new tools in project management. Social media tools have serious cultural changes in the business arena and more so in project management. Such changes include high levels of responsibility in all team

players, has cut out red tape, and more importantly, resulted quick response to project issues/opportunities.

5.3 Conclusion

The following conclusions can be from the research findings and the study objectives of the research study:

Technological innovation is a key driver to project performance. Technologies such as instant messaging, blogs, and video podcasts were found to be very effective in delivering projects successfully. Additionally, a cultural change was required to allow for the effective implementation of the tools, not only in project management, but in the business ecosystem as a whole. A conscious effort by the project implementation team, must be made for the successful adoption of the tools in project management.

5.4 Recommendations

The following recommendations have been arrived at based on the study results, findings and conclusions:

To ensure that the organization executives support the adoption and implementation of social media tools in project management, digital media teams should be introduced in the organization to work within the project management office and communication departments. As a project manager, to ensure that social media strategy is aligned to the business priorities, challenges and culture, they should ensure that social media strategy stems from the business strategy. Social media is one of the platforms that help the business meet its objectives.

As the project manager, new social media tools can be introduced from various work streams as the requirements deem fit. If the implementation of the tools addresses certain needs within the project cycle then they are adopted for use.

The project manager can mitigate against social media tools problem areas and harness its potential in project management through change management strategies. Some tools require to be phased for easier adoption whilst others require open testing across a wide network of users before adoption into policy.

5.5 Research Study Limitations

The study was conducted in a single department in one company, whose operating environment may differ from the rest of the company. In addition, some of the respondents refused to take

part in the study, citing confidentiality issues and fearing to be misquoted, which would result into being reprimanded by the company. Social media as a business tool is just gaining traction, thus some of the tools under study might have been new to the respondents. An awareness of the tools under study is crucial across the respondents for a fair generalization of sample group to be representative of the entire population.

5.6 Areas for Further Study

A study on the factors affecting social media tools use in project management should be carried out to develop more insight on the adoption trends in order to help organizations and project managers in particular, to consider so as to not only effectively implement such tools, but also to reap full benefits in using such tools in project management.

Comparative studies for communication service providers similar to Safaricom limited should be conducted as far as the effect of technological innovations on project management and performance is concerned.

References

- Aaron J. Shenhar, O. L. (1997). Mapping The Dimensions of Project Success. *Project Management Journal* 28, 2.
- Alter, S. (2013). Work System Theory: Overview of Core Concepts, Extensions, and Challenges for the Future. *Journal of the Association for Information Systems*, (14.2), 72-121.
- AtTask Inc. (2009). *Project Management + Social Networking = User-Driven Product Improvements*. Retrieved from <http://www.workfront.com/>:
<http://www.workfront.com/resources/pressrelease/project-management-social-networking-user-driven-product-improvements/>
- Babbie, B. E. (2013). *THE BASICS OF SOCIAL RESEARCH*. Cengage Learning; 6 edition.
- Baccarini, D. (1999). The Logical Framework Method for Defining Project Success. *Project Management Journal*.
- Benbasat, G. C. (1996). Diffusion and Adoption of Information Technology. In K. K.-H. (eds.), *Integrating Diffusion of Innovations and Theory of Reasoned Action Models to Predict Utilization of Information Technology by End-Users* (pp. 132 - 146). London: Chapman and Hall.
- Bergeron, L. R. (2008). Project Management Information Systems: An Empirical Study of their Impact on Project Managers and Project Success. *International Journal of Project Management* Vol. 26, 213 - 220.
- Boyd, S. (2009, April 7). *Social media and social tools defined*. Retrieved from SocialMedia.biz: <http://socialmedia.biz/2009/04/07/social-media-and-social-tools-defined/>
- Burger, R. (2014, October 6th). *How Social Media Can Improve Project Productivity*. Retrieved from <http://blog.capterra.com>: <http://blog.capterra.com/social-media-can-improve-project-productivity/>

- Business Daily. (2016, August). *Safaricom sets new record as market value hits Sh630bn*. Retrieved from Money Markets: <http://www.businessdailyafrica.com/Safaricom-sets-new-record-as-market-value-hits-Sh630bn/539552-2658306-145c56z/index.html>
- Davis, F. (1989). Percieved Usefulness, Percieved Ease of Use and User Acceptance of Information Technology. *MIS Quartely* 13, 319-340.
- Egg Van. (2013, Dcember). *Social Media for Project Success*. Retrieved from <http://eggvan.com/>: <http://eggvan.com/social-media-for-project-success/>
- Filev. (2010, June 3). *Project Management 2.0 - The Ultimate Benefits of the New Approach to Project Management*. Retrieved from <http://www.slideshare.net/>: <http://www.slideshare.net/Samuel90/project-management-20-4397688>
- G. Blanas, S. K. (2011). Social Networking Aspects of Project Management Teams for Effective Value Propositions. *Management of International Business and Economics Systems Conference* (pp. 372 - 382). <http://mibes.teilar.gr/proceedings/2011/oral/28.pdf>. Retrieved from <http://mibes.teilar.gr>: <http://mibes.teilar.gr>
- Gago, B. (2012). *Top 10 Challenges Enterprise Social Network Project Managers Face*. Retrieved from <http://www.tibbr.com/>: <http://www.tibbr.com/blog/topics/enterprise-2-0/top-10-challenges-enterprise-social-network-project-managers-face/>
- Gedpro. (2011, January 11). *Communication in the XXI Cemtuary: How web 2.0 affects project management*. Retrieved from Slideshare: <http://www.slideshare.net/gedpro/how-web-20-affects-project-management>
- Goodhue, D. a. (1995). Task-Technology Fit and Individual Performance. *MIS Quarterly*, (19: 2).
- Harrin, E. (2011). Social Media in a Project Environment, 2011 Survey Results.
- Harrin, E. (2016). Barriers to Social Media Adoption on Projects. In D. G. Silvius, *Project Management: Concepts, Methodologies, Tools, and Applications* (pp. 106-124). UK: Otobos Consultants Ltd.

- Ilan, J. K. (2005). Social ties, knowledge sharing and successful collaboration in globally distributed system development projects. *European Journal of Information System*, 37 - 48.
- IPLA. (2016). *Facts and Figures*. Retrieved from International Project Leadership Academy: http://calteam.com/WTPF/?page_id=1445
- Jansson, K. O., & Riikonen, M. U. (2009). *Social and Collaborative Internet Based Project Management*. Retrieved from <http://www.vtt.fi/>: http://www.vtt.fi/inf/julkaisut/muut/2009/38_Kim_Jansson.pdf
- Jemain, A. A.-O. (2007). Multistage median ranked set sampling fro estimating the population median. *Journal of Mathematics and Statistics*, vol 3, 58.
- Jones, H. R. (2012). Developing a Model for Social Media in Project Management Communications. *International Journal of Business and Social Science*, Vol 3, No. 3, 33 - 36.
- Junqueira, G. (2010). *The Social Media Standard for Project Management*. Retrieved from <http://www.projectsmart.co.uk/>: <http://www.projectsmart.co.uk/the-social-media-standard-for-project-management.html>
- Kahura, M. N. (2013). The Role of Project Management Information Systems towards the Success of a Project: The Case of Construction Projects in Nairobi Kenya. *International Journal of Academic Research in Business and Social Siences*.
- Khalifa, K. N. (2010). *A Research Framework on Social Networking Sites Usage: Critical Review and Theoretical Extension*. Retrieved from Springer Link: http://link.springer.com/chapter/10.1007%2F978-3-642-16283-1_21
- Kietzmann, J. H. (2011). Social Media? Get serious! Understanding the functional building blocks of social media. *Business Horizons*, pp. 241 - 251.
- Klynstra, M. (2012, August 21). *Social Media Meets Project Management*. Retrieved from <http://www.geneca.com/>: <http://www.geneca.com/social-media-meets-project-management/>
- Mafaz, S. M. (2012). *Contribution of Social Networking Tools in Project Management*. Retrieved from <https://www.academia.edu/>:

https://www.academia.edu/10917534/Contribution_of_Social_Networking_Tools_in_Project_Management

Merwe, L. (2012, August 20). *Can Social Media Drive Project Success*. Retrieved from

<http://www.virtualprojectconsulting.com>:

<http://www.virtualprojectconsulting.com/can-social-media-drive-project-success/>

Mugenda, O. M. (2003). *Research Methods: Quantitative and Qualitative Approaches (2nd ed.)*. Nairobi: Acts.

Papacharissi, Z. (2009). The Virtual Geographies of Social Networks: A Comparative Analysis of Facebook, LinkedIn and ASmallWorld. *New Media & Society, II (1&2)*, 199 - 220.

Perry, M. (2015, March 18). *Effective Project Management with Social Media Communications*. Retrieved from IntelliSyn: <http://www.intellisyn.com/wp-content/uploads/2016/03/IntelliSyn-Social-Media-Networking-18-3-15.pdf>

Pinkerton, W. (2003). *Project management : achieving project bottom-line success*. New York: McGraw-Hill.

PMI. (2008). Retrieved from A Guide to the Project Management Body of Knowledge (PMBOK GUIDE):

http://www.works.gov.bh/English/ourstrategy/Project%20Management/Documents/Other%20PM%20Resources/PMBOKGuideFourthEdition_protected.pdf

PMI. (2016). *What is Project Management?* Retrieved from Project Management Institute: <https://www.pmi.org/about/learn-about-pmi/what-is-project-management>

Premkumar, G., & Roberts, M. (1999). *Adoption of new information technologies in rural small businesses*. OMEGA.

ProjectPlace. (2012). *Social Project Management - Teamwork in the age of Web 2.0 & Social Media Interaction*. Retrieved from <http://www.collaboration.weconnect.com/>: http://www.collaboration.weconnect.com/uploads/229/dokumente/Social_Project_Management_Projectplace.pdf

R, H., & B., N. (2012). Developing a Model for Social Media in Project Management Communication. *International Journal of Business and Social Sciences*.

- Riaga, O. (2015). *Safaricom Numbers 2016 – How big is Safaricom?* Retrieved from <http://www.kachwanya.com>: <http://www.kachwanya.com/2016/05/23/safaricom-numbers-2016-how-big-is-safaricom/>
- Roberts, T. (n.d.). *Social Media: Delivering for Project Management?* Retrieved from <http://www.projectmanagementguide.org/>:
<http://www.projectmanagementguide.org/social-media-delivering-for-project-management>
- Rogers, E. &. (1996). Diffusion of Innovations. In I. M. (Eds.), *An Integrated Approach to Communication Theory and Research* (pp. Ch. 26, 409-420). New Jersey: Lawrence Erlbaum Associates.
- Rowley, P. J. (2002). Retrieved from http://www.psyking.net/HTMLObj-3843/using_case_study_in_research.pdf
- Safaricom. (2015). *Employees*. Retrieved from Safaricom Sustainability Report 2015: https://www.safaricom.co.ke/sustainabilityreport_2015/public/uploads/Employees.pdf
- Safaricom. (2016). *About Safaricom*. Retrieved from <http://www.safaricom.co.ke/>:
<http://www.safaricom.co.ke/about-us/about-safaricom>
- Schettini, F. (2011, March 10). *Social Media: A Growing Factor in Project Success*. Retrieved from <http://www.cioinsight.com>:
<http://www.cioinsight.com/print/c/a/Expert-Voices/Social-Media-a-Growing-Factor-in-Project-Success-806642>
- Silvius, D. G. (2016). Social Project Management. *PMI World Journal*.
- Sponselee, M. (2006). Effects of Social Media on Project Management. The Netherlands.
- Statista. (2016). *Statistics and facts about Social Networks*. Retrieved August 17, 2016, from The Statistics Portal: <http://www.statista.com/topics/1164/social-networks/>
- Tribalcafe. (2016). *WHAT IS A SOCIAL MEDIA STRATEGY DEFINITION AND THOUGHTS*. Retrieved from TRIBALCAFE: <https://www.tribalcafe.co.uk/what-is-social-media-strategy-definition/>

- Trilog Group. (2012). *Social Project Management: Engaging the Social Network to Deliver Project Success*. Retrieved from <http://www.triloggroup.com/>:
http://www.triloggroup.com//portal/website/content/SocialPM_WP.pdf
- V. Venkatesh, F. D. (2000). A Theoretical Extension of the Technology Acceptance Model: Four Longitudinal Field Studies. *Management Science* 46, 186 - 204.
- Wikipedia. (2015). *PRINCE2*. Retrieved from Wikipedia:
<http://pt.wikipedia.org/wiki/PRINCE2>
- Wintera, M., Smith, C., Morris, P., & Cicmil, & S. (2006). Directions for Future Research in Project Management: The Main findings of a UK Government-funded research network. *International Journal of Project Management*, 24(8), 638 - 649.
- Wynne, A. J. (2015). A conceptual model: impact of usage of social media tools to enhance project management. *European Journal of Management Studies*.
- Yin, R. K. (1994). *Case study research: Design and methods*. Newbury Park, CA: Sage.
- Youker, R. (2002, February). *Max's Project Management Wisdom*. Retrieved from
<http://www.maxwideman.com>:
<http://www.maxwideman.com/guests/typology/projects.htm>

Appendix 1

The survey is being conducted for the research regarding social media tools and project performance: the case of Safaricom Ltd. The data collected will be used to assess what social media tools were deemed most helpful in project management. Your participation will greatly help to obtain the results.

Section A: Demographic Information

Please respond appropriately by encircling (O) where applicable:

<p>i. Gender</p> <p>1. Male ()</p> <p>2. Female ()</p>	<p>ii. Age</p> <p>1. 25 or less ()</p> <p>2. 26 - 30 ()</p> <p>3. 31 - 35 ()</p> <p>4. 36 - 40 ()</p> <p>5. 41 – 45 ()</p> <p>6. 46 – 50 ()</p> <p>7. Over 50 ()</p>
<p>iii. Experience in Project Management/implementation/delivery (In general, not only in present company)</p> <p>1. 1 year or less ()</p> <p>2. 1 – 3 years ()</p> <p>3. 4 – 5 years ()</p> <p>4. 6 – 10 years()</p> <p>5. Over 10 years ()</p>	<p>iv. Experience in present company.</p> <p>1. 1 year or less ()</p> <p>2. 1 – 2 years ()</p> <p>3. 3 – 5 years ()</p> <p>4. 6 – 10 years()</p> <p>5. Over 10 years ()</p>
<p>v. Project Role</p> <p>1. Project Management ()</p> <p>2. Program Management ()</p> <p>3. Project/Program Support (Project Team) ()</p> <p>4. Change Management ()</p> <p>5. Any other (Specify)</p>	<p>vi. How long have you used, or have been using social media tools in project management?</p> <p>1. Have not used any tool ()</p> <p>2. Less than a year ()</p> <p>3. 1- 3 years ()</p> <p>4. 4 - 6 years ()</p> <p>5. 7 – 10 years ()</p> <p>6. Over 10 years ()</p>

Section B

1. Social Media Tool(s) Usage

In the table below, please indicate the level to which you use each of the following social media tool(s) for each usage area by encircling () or tick (√) where applicable: High (H), Medium (M), or Low (L).

Table 1: Social Media Tools extent of use

Social Media Tools	Level of use (indicate H, M or L)									Not Applicable	Don't know what this is
	Business			Project Work			Personal				
Facebook	H	M	L	H	M	L	H	M	L		
LinkedIn	H	M	L	H	M	L	H	M	L		
Twitter	H	M	L	H	M	L	H	M	L		
Instant Messaging (e.g. WhatsApp)	H	M	L	H	M	L	H	M	L		
Blog	H	M	L	H	M	L	H	M	L		
Wiki	H	M	L	H	M	L	H	M	L		
Podcast	H	M	L	H	M	L	H	M	L		
Video podcast	H	M	L	H	M	L	H	M	L		
Other Social network (specify)											

Adopted from: Harrin (2011)

2. Other Tools

Item	Project Management Task/Area	Tool	Comment

i. What social media tool(s) would you recommend and why?

ii. To what extent are social media tools important to you? Please tick (√) where applicable. Multiple options are accepted.

<input type="checkbox"/>	Communication efficiency
<input type="checkbox"/>	Collaboration with team members
<input type="checkbox"/>	Collaboration with clients
<input type="checkbox"/>	Networking
<input type="checkbox"/>	Cost saving
<input type="checkbox"/>	Knowledge sharing

Section C: Major Types of Projects Based on Product of Project

In the table below, please provide the primary social media tool(s) used for each type of project by responding appropriately by encircling () according to level of use: High (H), Medium (M); Low (L); and Not Applicable (NA) where applicable.

Table 2: Project Type and Project Product Type

Project Type		Project Product (Examples)	Social Media tool(s) used, (primary)	Level of use (indicate H, M, L or NA)
1.	Administrative	installing a new accounting system or Customer Relationship Management system (CRM), confirming project schedule		H M L NA
2.	Construction	a datacenter or base station		H M L NA
3.	Software Development	a mobile/online app		H M L NA
4.	Design of Plans	architectural or engineering plans, e.g. new network rollout		H M L NA
5.	Equipment or System Installation	Internet installation or data center collocation		H M L NA
6.	Event or Relocation	Marketing or a move into a new building		H M L NA
7.	Maintenance of Process Industries	Infrastructure or service upgrade		H M L NA
8.	New Product Development	a new product or service		H M L NA
9.	Research	a feasibility study		H M L NA
10.	Other			H M L NA
11.	Other			H M L NA

Adopted from: Youker (2002)

Section D

1. Social media use in project management

Please rate how much you agree with the following statements (√) by selecting one of the following: 5: Strongly Agree (SA), 4: Agree (A), 3: Neutral (N), 2: Disagree (D), and 1: Strongly Disagree (SD)

Item	Description	SA	A	N	D	SD
1.	Social media tools offer me real advantages over the way I usually manage projects					
2.	I have more fun managing projects because of using social media tools.					
3.	Social media tools are better than using other tools to manage projects					
4.	I find social media tools useful in my job					
5.	I accomplish tasks more quickly using social media tools					
6.	Using social media tools increase my productivity and performance					
7.	Social media tools provide an excellent vehicle for fostering communities of best practice					
8.	A cultural change, which enables new ways of working, is needed for social media tools initiatives to be successful					
9.	Social media tools expose project managers/teams to a framework of experience, collaboration and knowledge-sharing					

i. How do social media tools assist in knowledge management in project management?

ii. What cultural change has social media brought about in project management?

iii. How do social media tools expose project managers and their teams to new experiences, collaboration and knowledge sharing?

2. Benefits of social media tools in project management

In the table below, please tick (√) where applicable:

Financial benefits	Yes	No
Savings on meeting costs		
Savings on telephone costs		
Savings on recruitment costs		
No financial benefits realized		
Efficiency benefits	Yes	No
Improved collaboration		
Improved team morale		
Improved communication		
No efficiency benefits realized		

iii. Please list the financial benefits not listed above.

iv. Please list the efficiency benefits not listed above.

v. Briefly explain how social media tools are used in team collaboration.

vi. It is agreed that social media tools use results in efficient communication. How is this so?

Section E: Challenges in using social media tools in project management

Please rate how much you agree with the following statements (√) by selecting one of the following: 5: Strongly Agree (SA), 4: Agree (A), 3: Neutral (N), 2: Disagree (D), and 1: Strongly Disagree (SD)

Item	Description	SA	A	N	D	SD
1.	Social media is just another technology and not something that enables new ways of working					
2.	IT departments and leaders remain wary in the use of social media tools and yet users see them as productivity tools.					
3.	Adopting and implementing social media tools is more than a technical challenge.					
4.	Support from senior management is not important in the implementation of social media tools in project management.					
5.	It is not necessary to start with test cases to prove the value of social tools in project management					
6.	It is not necessary to align the vision for enterprise social to the current business priorities, challenges and culture.					
7.	Company culture is the biggest contributor to resistance to change in using new tools in project management					

- i. How can organization executives support the adoption and implementation of social media tools in project management?**

- ii. As a project manager, how do you ensure that the social media strategy is aligned to business priorities, challenges and culture?**

- iii. As the project manager, how do you introduce new social media tools to the team, organization?**

- iv. How would you mitigate against social media tools problem areas and harness its potential in project management?**

Tool(s) Adoption

In the table below, please tick (√) where applicable:

Have tools been officially adopted?	Yes	No
Tool(s) been adopted across entire organization		
Tool(s) been adopted only in department		
Tool(s) not officially in use, but respondent uses them anyway		

Adopted from: Harrin (2011)

i. Please briefly explain any challenge(s) not listed above?

ii. What recommendation(s) would you provide to mitigate against the above mentioned challenge(s)