



**UNIVERSITY OF NAIROBI**

**SCHOOL OF COMPUTING & INFORMATICS**

**TOWARDS AN INTERNET OF THINGS ARCHITECTURE FOR  
AIR QUALITY MONITORING SYSTEM IN KENYA**

**BY**

**VICTOR OMONDI OBURU**

**(P54/73366/2014)**

**SUPERVISOR**

**CHRISTOPHER MOTURI**

**A project report submitted in partial fulfillment of the requirements for the award of  
Master of Science in Information Technology Management of the University of Nairobi.**

**OCTOBER 2016**

# DECLARATION

## STUDENT

I declare that this research project is my original work and has not been presented in any other university or academic institution for an academic award.

**NAME: VICTOR OMONDI OBURU**

**REG: P54/73366/2014**

Signature: \_\_\_\_\_

Date: \_\_\_\_\_

## SUPERVISOR

This research project has been submitted in partial fulfillment of the requirement of the Master of Science Degree in Information Technology Management of the University of Nairobi with my approval as the University supervisor.

Signed: \_\_\_\_\_

Date: \_\_\_\_\_

Christopher A. Moturi

School of Computing and Informatics, University of Nairobi

## **ACKNOWLEDGEMENT**

To the greatest extent, I want to give thanks to the almighty for giving me good health of the body, mind and spirit throughout the whole process of this research. I would also like to express my ardent gratitude to my supervisor Mr. Christopher Moturi for his greatest help and time he availed me for consultation and providing me with very important guidance throughout this research. A lot of appreciation also goes to the entire panel three members: Samuel Ruhiu, Dan Orwa and Peter Waiganjo for their great guidance and time they dedicated to this research.

A huge warm thanks also goes to my parents who supported me throughout the project. I also want to take this opportunity to thank my classmates, colleagues at work for the support they availed me towards my successful completion of this project.

## **ABSTRACT**

The proliferation of smart objects capable of communicating and actuating in a network has created the Internet of Things (IoT) which is made up of sensors and actuators which blend seamlessly with the environment around us collect data from the environment and allow the sharing of information across platforms. This has enabled cheaper and more scalable means of gathering, processing and presenting air quality data that is not only useful to the environmental authorities but also to the citizens. This research presents the IoT enabling technologies, architectures and how they have been used in developing air quality monitoring systems. An architectural framework based on these enabling technologies, architectures and the best practices from several cases previous cases was designed. Finally an air quality monitoring system that is based on this architecture was developed and tested. The research concludes that the benefits that can be realized by air quality monitoring systems based on this architecture include: sensing accuracy, large area coverage and monitoring, minimal human interaction through remote sensing and monitoring, ability to integrate these systems to the existing systems through the use of already implemented technologies that are regarded as the enablers of IoT and effective dissemination of air quality information.

**Keywords:** Internet of Things; air pollution; air quality monitoring; sensors; wireless sensor networks; actuators; architecture.

# TABLE OF CONTENTS

DECLARATION .....	i
ACKNOWLEDGEMENT .....	ii
ABSTRACT.....	iii
TABLE OF CONTENTS.....	iv
LIST OF FIGURES .....	vi
LIST OF ABBREVIATION.....	viii
CHAPTER ONE .....	1
INTRODUCTION .....	1
1.1. Background .....	1
1.2. Statement of the problem .....	2
1.3. Research Objectives .....	2
1.4. Justification of the project.....	3
CHAPTER TWO .....	4
2. LITERATURE REVIEW .....	4
2.1. Introduction .....	4
2.2. Internet of Things.....	4
2.3. Enabling Technologies.....	5
2.4. IoT Architectures.....	9
2.5. IoT and Air quality monitoring .....	12
2.6. The proposed approach .....	22
CHAPTER THREE .....	25
3. RESEARCH METHODOLOGY .....	25
3.1. Research design.....	25

3.2.	Designing the air quality architectural model .....	26
3.3.	Designing the air quality monitoring system .....	28
3.4.	Data collection.....	31
3.5.	Data analysis .....	33
CHAPTER FOUR.....		34
4.	FINDINGS AND PROTOTYPE DESIGN .....	34
4.1.	Introduction .....	34
4.2.	Air quality monitoring methods currently being used in Kenya.....	34
4.3.	Locations of the equipment and tools used for air quality monitoring. ....	38
4.4.	Cost of the tools and equipment's in terms of purchase, operation and maintenance ...	38
4.5.	How the air quality data disseminated to the public. ....	38
4.6.	Frequency with which these air quality information is availed to the public .....	39
4.7.	Results from the Development Kit Prototype .....	40
4.8.	Interpretation of the results .....	45
CHAPTER FIVE .....		47
5.	SUMMARY, CONCLUSIONS AND RECOMMENDATIONS .....	47
5.1.	Introduction .....	47
5.2.	Evaluation of Research Objectives .....	47
5.3.	Summary of Findings .....	48
5.4.	Conclusions .....	49
5.5.	Limitation of the Study and Suggestions for Future Research.....	49
5.6.	Recommendations .....	50
BIBLIOGRAPHY.....		51

# LIST OF FIGURES

Figure 1: Diagram by (Patrick & Peter, 2009)depicting the IoT. ....	4
Figure 2: IoT elements by (Al-Fuqaha, 2015) .....	8
Figure 3: IoT Architectures by (Miao, Ting-Jie, Fei-Yang, Jing, & Hui-Ying, 2010), (Zhihong, et al., 2011). ....	9
Figure 4: IoT arhitecture by (Gomez et al., 2010) .....	11
Figure 5: Overall architecture of the IIS based on IoT by (Shifeng, et al., 2014). ....	12
Figure 6: Vehicular Pollution and Status Monitoring by (Rajalakshmi, Karthick, & Valarmathy, 2015) .....	14
Figure 7: Arduino UNO Board .....	15
Figure 8 GSM gas sensor .....	16
Figure 9 CO2 Sensor.....	16
Figure 10: Real time air quality monitoring by (Rajalakshmi, Karthick, & Valarmathy, 2015)..	17
Figure 11: Static Sensor Network (Rajalakshmi, Karthick, & Valarmathy, 2015) .....	19
Figure 12 Community Sensor Network (CSN) (Rajalakshmi, Karthick, & Valarmathy, 2015)..	20
Figure 13Vehicle Sensor Network (VSN) (Rajalakshmi, Karthick, & Valarmathy, 2015) .....	21
Figure 14 System architecture adopted from (Rajalakshmi, Karthick, & Valarmathy, 2015) .....	26
Figure 15: System Overview .....	28
Figure 16: Electrical System.....	29
Figure 17: Sensor connection to Arduino .....	30
Figure 18: Development Kit Prototype.....	32
Figure 19: Ozonesonde sounding system .....	34
Figure 20: Generated data during flight.....	35
Figure 22 Results from the ozone analyser (Zablon, et al., 2015). ....	35
Figure 21: Surface ozone analyser (Zablon, et al., 2015). ....	36

Figure 23 Dobson and its sample data set (Zablon, et al., 2015).....	36
Figure 24: UNEP Air Quality Monitoring System (DEWA).....	37
Figure 25 Connecting MQ-2 gas sensor to Arduino and breadboard .....	40
Figure 26: Air quality data between block S and N.....	41
Figure 27 Results from UNEP's air quality monitoring system between block N and S .....	42
Figure 28: Sensor data readings at the delegates parking area .....	43
Figure 29 Air Quality data by UNEP's Air Quality Monitoring System .....	43
Figure 30 MQ-7 Sensor data readings at Eastern Car Park in UN complex.....	44
Figure 31 Air quality data from UNEP's Air quality monitoring system in the Eastern car park area.....	45
Figure 32: Air quality data form the months of May – August (DEWA).....	46



## LIST OF ABBREVIATION

**3GPP:** 3rd Generation Partnership Project

**AG:** Application gateway

**APP:** application software for different platforms and tasks

**6LoWPAN/IEEE:** Internet Protocol version 6 over Low power Wireless Personal Area Networks

**CoAP/UDP:** Constrained Application Protocol/User Datagram Protocol

**DaaS:** Data as a Service

**EMCA:** Environmental Management and Coordination Acts

**EPC:** Electronic Product Codes

**ETSI:** European Telecommunications Standards Institute ETSI

**EXI:** Efficient XML Interchange

**ETL:** Extraction–transformation–loading

**GSM:** Global System for Mobile communications

**HTTP / TCP:** Hyper Text Transfer Protocol Transmission Control Protocol

**IaaS:** Infrastructure as a Service

**IoT:** Internet Of Things

**IP:** Internet Protocol

**JDBC:** Java database connectivity

**M2M:** Machine to Machine

**MTC:** Machine-Type Communications

**NFC:** Near Field Communication

**OLAP:** on-line analytical processing

**OWL:** Web Ontology Language

**PaaS:** Platform as a Service

**RESTful:** representational state transfer

**RDF:** Resource Description Framework

**RFID:** Radio-frequency identification

**RODB:** Real-time operational database

**ROLAP:** relational OLAP

**RTOS:** Real-Time Operating Systems

**SaaS:** Software as a Service

**SAN:** Sensors Area Network

**SBC:** Single Board Computers

**SIG:** Special Interest Group

**SOA:** Service Oriented Architectures

**TCP:** Transmission Control Protocol

**UMTS:** Universal Mobile Telecommunications System

**WSN:** Wireless Sensor Networks

# CHAPTER ONE

## INTRODUCTION

### 1.1. Background

Internet of Things is a contemporary communication archetype that predicts a near future where the “things” hereby referred to as smart objects we interact with on a daily basis will be equipped with microcontrollers, digital communication appliances such as transceivers, and the most suited protocol stacks that will give these smart objects the ability to communicate with one another and with the users thereby making these objects become an integral part of the Internet (Luigi, Antonio, & Giacomo, 2010).

Ubiquitous sensing enables the smart objects measure, deduce and understand environmental elements ranging from the natural environments to the manmade urban environments. The proliferation of these smart objects combined with sensors and actuators has created the IoT concept and has brought the ability to easily obtain data from the environment such as the air quality as well as the ability to share the obtained information across multiple homogeneous and heterogeneous platforms and thereby leading to the development of a common operating picture (Jayavardhana, Rajkumar, Slaven, & Marimuthu, 2013).

The continuous development of the IoT concept aims at making the internet more immersive and pervasive thereby enabling devices such as sensors, actuators, displays, actuators etc. to easily communicate with each other and be easily accessed and controlled remotely. The IoT concept will therefore support the continuous improvement and development of applications that will make use of the large amount and variety of information generated by such objects. This will thereby lead to the efficient provision of services to the citizens, organizations and public administration. (Paolo, Giuseppe, Antonio, & Luca, 2013).

Attempts have been made to monitor urban air quality. This has been through the installation of air non mobile air quality monitoring stations in selected parts of the urban areas by the environmental authorities. These fixed monitoring stations measures the air pollution elements within certain proximity. The monitoring stations however requires careful placement in order to be effective. This is however not possible in most cases as there are continuous changes in urban arrangement and development as well as budget constraints that most of the times prevents

relocating and addition of new monitoring stations to the existing network of the monitoring stations. (Salvatore, Giuseppe, Gloria, Daniele, & Salvator, 2014).

The continuous developments in the field of IoT have therefore made it possible to obtain air quality data through the use of cheap and scalable air quality monitoring systems that employ IoT architectures and appropriate technologies. Among the successfully developed air quality monitoring systems based on IoT in research projects such as (Shifeng, et al., 2014), (Srinivas D. , et al., 2013), (Jiachen, Jianxiong, Zhihan, & Houbing, 2015)

This research therefore aims at taking advantage of the research that has been done by others in building air quality monitoring systems based on IoT and proposes an architecture that can be used for building an air quality monitoring system in Kenya that uses appropriate enabling technologies that are readily available and affordable.

## **1.2. Statement of the problem**

Ideally every city should have air quality monitoring and control. This can help counter the increase in air pollution in the large urban areas that is continuously leading to sufficiently great effects on human health and environment.

The high cost of acquiring, maintaining and adding more air quality monitoring systems limits the number monitoring stations. This therefore implies that air quality cannot be efficiently obtained. The data obtained is also not a full representation of the accurate air condition of the whole part of the country but simply an approximation. To overcome these problems it is necessary to adopt more pervasive monitoring systems.

## **1.3. Research Objectives**

This study had four objectives:

1. To explore how IoT has been used in developing various systems for environmental monitoring with a detailed study on air quality monitoring.
2. To identify the various IoT enabling technologies and architectures used for environmental monitoring with an emphasis on air quality monitoring.
3. To investigate the current air quality monitoring systems in Kenya.
4. To propose IoT architecture for air quality monitoring and develop an air quality monitoring system prototype built on the proposed architecture.

#### **1.4. Justification of the project**

This project is justified as it aims at coming up with an IoT architecture that can be used for developing an efficient air quality monitoring system that is scalable, low-cost, portable and can obtain air quality data with a wide coverage with minimal or no human interaction.

The system will also ensure the easy access to the air quality information to the citizens as well as the environmental authorities to ensure that timely actions can be taken to maintain good ambient and occupational air quality standards as set by the EMCA.

Air quality monitoring system with efficient and scalable platforms that monitors varied locations by heterogeneous sensing infrastructure and remittance of real-time air quality information have been developed and used in the developed countries (Deepali & Satbir, 2013). By using the readily available enabling technologies and borrowing from these test beds, realizing an IoT enabled air quality monitoring system is therefore feasible in Kenya.

# CHAPTER TWO

## LITERATURE REVIEW

### 2.1. Introduction

In this section, the works done by other researchers and scholars on IoT as well as the areas of application and, including air pollution monitoring and control were examined. It began by defining and giving an overview of IoT. This was followed by a comprehensive study on the enabling technologies and architectures of IoT. A survey on the areas of application of IoT in different sectors with examples of the specific applications was also be carried out.

### 2.2. Internet of Things

Guillemin & Friess (2009) defines the IoT as a universal network infrastructure that links physical and virtual “things” i.e. smart objects by using the communication and the data capture capabilities of these objects. This universal network infrastructure consists of already established internet and network evolution. This will therefore give the objects identification, sensing, communication capabilities thereby enhancing a high degree of self-governing data collection, data transfer and network connectivity and interoperability by these objects. (Patrick & Peter, 2009).



Figure 1: Diagram by (Patrick & Peter, 2009) depicting the IoT.

IoT is therefore a paradigm where the smart object or things are equipped with tools for identification, sensing, networking and the information processing. This will therefore allow the objects to connect to one another and transfer information among them through the internet and other devices. (Jayavardhana, Rajkumar, Slaven, & Marimuthu, 2013).

Other concepts leading to the successful development of the IoT include the ability of the devices to send their data to the cloud through cloud computing. This has ensured that data can be captured anywhere by the smart object and be stored in the cloud thereby enabling the users to retrieve and access the data from anywhere thereby creating a smart, ubiquitous and always-connected systems.

With the use of objects that's have unique identification and that can be given unique addresses as well as virtual representation in an Internet oriented structure, these smart objects such as the sensors or the actuators can provide the information from their surroundings and well as information about them and also be able to relay these information in real-time.

The IoT is also characterized by pervasive “omnipresent” and ubiquitous computing concepts (Charith, Arkady, Peter, & Dimitrios, 2014). These paradigms are further enhanced by the use of large scale embedded sensors and actuators. With these objects having unique addresses and connected to the internet, this allows the objects to send the information about them to the internet and therefore be accessed easily and remotely by users. Since these objects are also able to sense their surroundings and relay the information across different platforms, they have become useful tools for solving the technological complexities and thereby enabling certain information about the environment be obtained automatically with minimal or no human interaction. (Bhole, 2015).

### **2.3. Enabling Technologies**

The IoT enables the participating objects link with each other and share information across among them. IoT therefore transforms these objects from being traditional i.e. being un-able to communicate with others to being smart i.e. being able to link and communicate with other object. This is achieved through the use of the concepts such as ubiquitous and pervasive computing. The use of embedded sensors with the enabling technologies such as networks, internet protocols and applications further provides an avenue for implementing the IoT. (Al-Fuqaha, 2015)

In this section, several research works that covers different aspects of the IoT technologies were examined. Among the examined work include an overview of the works done by the researches (Luigi, Antonio, & Giacomo, 2010) who overviewed the main communication technologies including the wired, wireless the elements of wireless sensor networks.

Generally, the IoT enabling technologies i.e. the building blocks can be broadly grouped into IoT elements. Understanding these building blocks is therefore as it aids in the understanding how IoT functions. (Al-Fuqaha, 2015).

The IoT enabling technologies are presented in the below sections as six main blocks. These building blocks are vital for delivering the functionalities of IoT.

*a) Identification technologies*

This involves giving the objects unique identities to ensure that they can be monitored independently and provide data uniquely. There are many techniques used in IoT to identify object and these include: EPC and ubiquitous codes (Koshizuka & Sakamura, 2010).

Providing the unique identity to these smart objects/thing is useful in identifying these objects within the network of multiple objects. This can be achieved by the use of IP addresses such as (IPv4, IPv6 or 6LoWPAN) which can be public or private and the use of identification (ID) codes.

*b) Sensing technologies*

This is the ability of the smart objects to obtain data from their environment/surroundings and send these data to a central storage such as a data warehouse, database, or cloud. Sensing is achieved by employing the use of The IoT sensors such as smart sensors, actuators and wearable sensing devices. IoT products such as Arduino, Raspberry PI, and BeagleBone Black are built based on these sensors in addition to built-in TCP/IP and security functionalities. The sensors must therefore be connected to a central data server to allow the data be accessible by users. (Al-Fuqaha, 2015)

*c) Communication technologies*

These technologies include RFID, NFC and UWB that connects the heterogeneous participating IoT in an integrated manner. The ideal communication among the participating objects involves

the use of low power methods techniques in the communication links. The protocols used in these technologies include wireless fidelity, bluetooth among others. More recently developed protocols include the low-rate wireless personal area networks (IEEE 802.15.4)

The technologies that enables communication is further discussed as below:

1. RFID technology uses M2M concept where a tag acts as one machine and a reader acts as another machine. The tag can simply be a chip for providing a unique identity. The reader on the other hand sends a signal to the tag querying information and once it receives the information through reflection, it sends the information to a database. The tags used in this technology can be active or dormant. The active tags are powered by batteries while the dormant ones are not powered.

2. NFC: This communication protocol is useful where high frequency band of upto 13.56 MHz is needed and the data rate is over 424 kilobits per second. The distance between the active readers and the passive tags should not exceed 10cm. (Al-Fuqaha, 2015).

3. The UWB communication technology supports communications that requires short distances and has low power demand and a high band-width (Zhang-Cheng & Jia-Sheng, 2011)

#### *d) Computation technologies*

Computation is composed of processing units such, software applications and various hardware platforms. These components are Processing units: These includes as microcontrollers such as Arduino, Raspberry PI, Beagle Bone; microprocessors, SOCs, FPGA's, software (Operating systemseg TinyOS, LiteOS) and hardware.

2. Hardware platforms include, FriendlyARM, Intel Galileo, , Gadgeteer, , Cubieboard, , WiSense, Mulle, and T-Mote Sky.

#### *e) Services*

IoT enabling services can be grouped Identity-related, Information Aggregation, Collaborative-Aware and Ubiquitous Services (Xing, Wang, & Li, 2010) (Matthew & Simon, 2011). The Identity-related are used for identifying the IoT objects, Information Aggregation Services are



used for combining all the collected data from the sensors. They also provide a summary of the data before it is processed and sent the application interfaces. Collaborative-Aware Services are used for collecting data collectively from the participating sensors. Ubiquitous Services on the other hand provides the ability to collect data from anywhere and at any time and also to be able to send data to anyone irrespective of their locations. It makes the services be omnipresent.

f) *Semantics*

Semantic can be seen as the ability of the IoT nodes to obtain processed information in a smart manner. The nodes therefore act as human beings and are thus able to obtain and provide data that has meaning. (Payam, Wei, Cory, & Kerry, 2012). These capabilities are enhanced by the use of Semantic Web technologies (John, Takuki, Peintner, & Rumen, 2011) and EXI. These

IoT elements have been summarized in a diagram (Al-Fuqaha, 2015) and are shown in figure 2:

IoT Elements		Samples
Identification	Naming	EPC, uCode
	Addressing	IPv4, IPv6
Sensing		Smart Sensors, Wearable sensing devices, Embedded sensors, Actuators, RFID tag
Communication		RFID, NFC, UWB, Bluetooth, BLE, IEEE 802.15.4, Z-Wave, WiFi, WiFiDirect, , LTE-A
Computation	Hardware	SmartThings, Arduino, Phidgets, Intel Galileo, Raspberry Pi, Gadgeteer, BeagleBone, Cubieboard, Smart Phones
	Software	OS (Contiki, TinyOS, LiteOS, Riot OS, Android); Cloud (Nimbits, Hadoop, etc.)
Service		Identity-related (shipping), Information Aggregation (smart grid), Collaborative-Aware (smart home), Ubiquitous (smart city)
Semantic		RDF, OWL, EXI

Figure 2: IoT elements by (Al-Fuqaha, 2015)

## 2.4. IoT Architectures

IoT architecture aims at interconnecting multitude of heterogeneous smart objects through the internet. This can be realized through the use of flexible architectures that are modelled using different layers. (Al-Fuqaha, 2015)

Out of all the already proposed layered architectures, an agreement has not been reached on the most acceptable reference model. (Luis, et al., 2014). Meanwhile, there are some projects like IoT-A (Ángel, Álvaro, Rubén, & Roberto, 2014) that have designed some commonly used architectures as shown in figure 3 with the most common one being the 3-layer architecture (Khan et al., 2012), (Zhihong, et al., 2011), (Miao, Ting-Jie, Fei-Yang, Jing, & Hui-Ying, 2010) The architectures are discussed as below:

### 2.4.1. Architectures based on layered models

Fig. 3 illustrates architectures by (Miao, Ting-Jie, Fei-Yang, Jing, & Hui-Ying, 2010), (Zhihong, et al., 2011). An overview of the enabling technologies and the IoT elements used in all the layers of these IoT architectures are discussed in the section below:

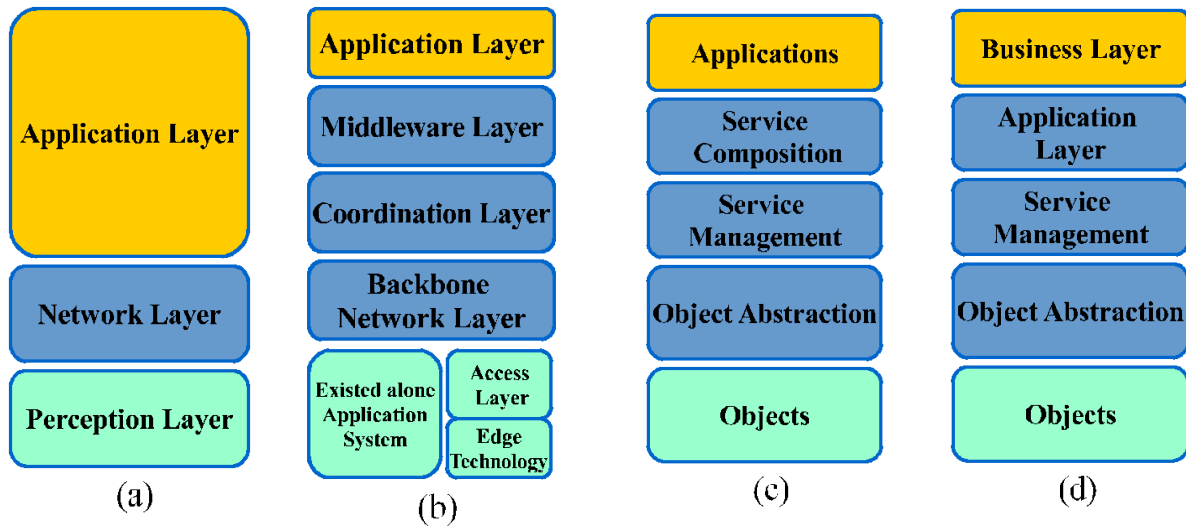

Figure 3: IoT Architectures by (Miao, Ting-Jie, Fei-Yang, Jing, & Hui-Ying, 2010), (Zhihong, et al., 2011).

**a) Perception layer**

This is the layer where the smart objects such as the sensors and actuators reside in. It is also known as the objects layer. The objects in this layer therefore carry out functions such as collecting and processing information from the surrounding environment as well as sending these information to a central server. A configuration of the heterogeneous objects in this layer can be achieved through the use of a standard plug and play technique. (Miao, Ting-Jie, Fei-Yang, Jing, & Hui-Ying, 2010), (Zhihong, et al., 2011).

**b) Object Abstraction Layer**

This is the layer that transports the data from the perception layer to the middle-ware layer in a secure manner. The data is sent to this layer with the aid of communication technologies e.g. 3G, infrared, RFID, Wi-Fi, ZigBee, GSM and Bluetooth. (Miao, Ting-Jie, Fei-Yang, Jing, & Hui-Ying, 2010), (Zhihong, et al., 2011).

**c) Middleware Layer**

This layer matches different services to different requesters based on the requester's identification. It allows the application programmers work with non-similar/heterogeneous objects without being limited by the hardware platforms. The layer also carries out information processing, decision making as well as the delivery of the needed services remotely over the communication network (Miao, Ting-Jie, Fei-Yang, Jing, & Hui-Ying, 2010), (Zhihong, et al., 2011).

**d) Application Layer**

This is the layer that allows the users to access all the services they need form the IoT system through an interface. (Miao, Ting-Jie, Fei-Yang, Jing, & Hui-Ying, 2010), (Zhihong, et al., 2011)

**e) Business Layer**

This is the layer responsible for the overall management of the whole system. The elements managed includes the all the object and communication activities as well as all the involved services. This layer also visualizes the data from the application layer to clients in an understandable manner through the use of tools such as graphs, UML diagrams, flowcharts and other visualization tools(Miao, Ting-Jie, Fei-Yang, Jing, & Hui-Ying, 2010), (Zhihong, et al., 2011).

## 2.4.2. Architecture by (Ángel, Álvaro, Rubén, & Roberto, 2014)

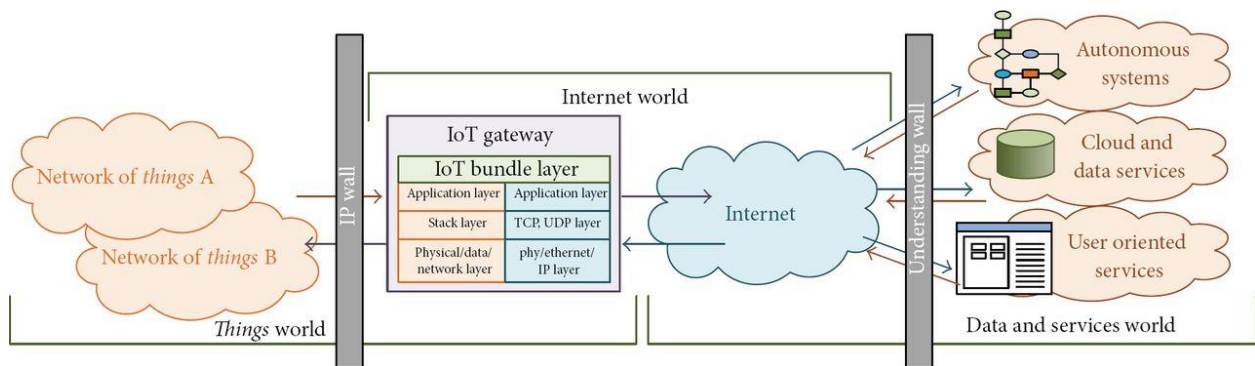

Figure 4: IoT architecture by (Gomez et al., 2010)

Most IoT implementations follow an architecture that contains different worlds each of them with their own characteristics; Figure 4 shows an example (Kim, Kaspar, Gomez, & Bormann, 2012) (Gomez et al., 2010). They argue that the things world relates to micro-electromechanical systems, smart sensors, simple HMI's, and so forth, which relate to one another in networks of things and ubiquitously interacts with their surroundings.

## 2.5. IoT and Air quality monitoring

### 2.5.1. IoT based IIS for Regional Environmental Monitoring and Management

This research was carried out by (Shifeng, et al., 2014) . In this study, the researchers implemented an Integrated System based on the architecture as shown in figure 5.

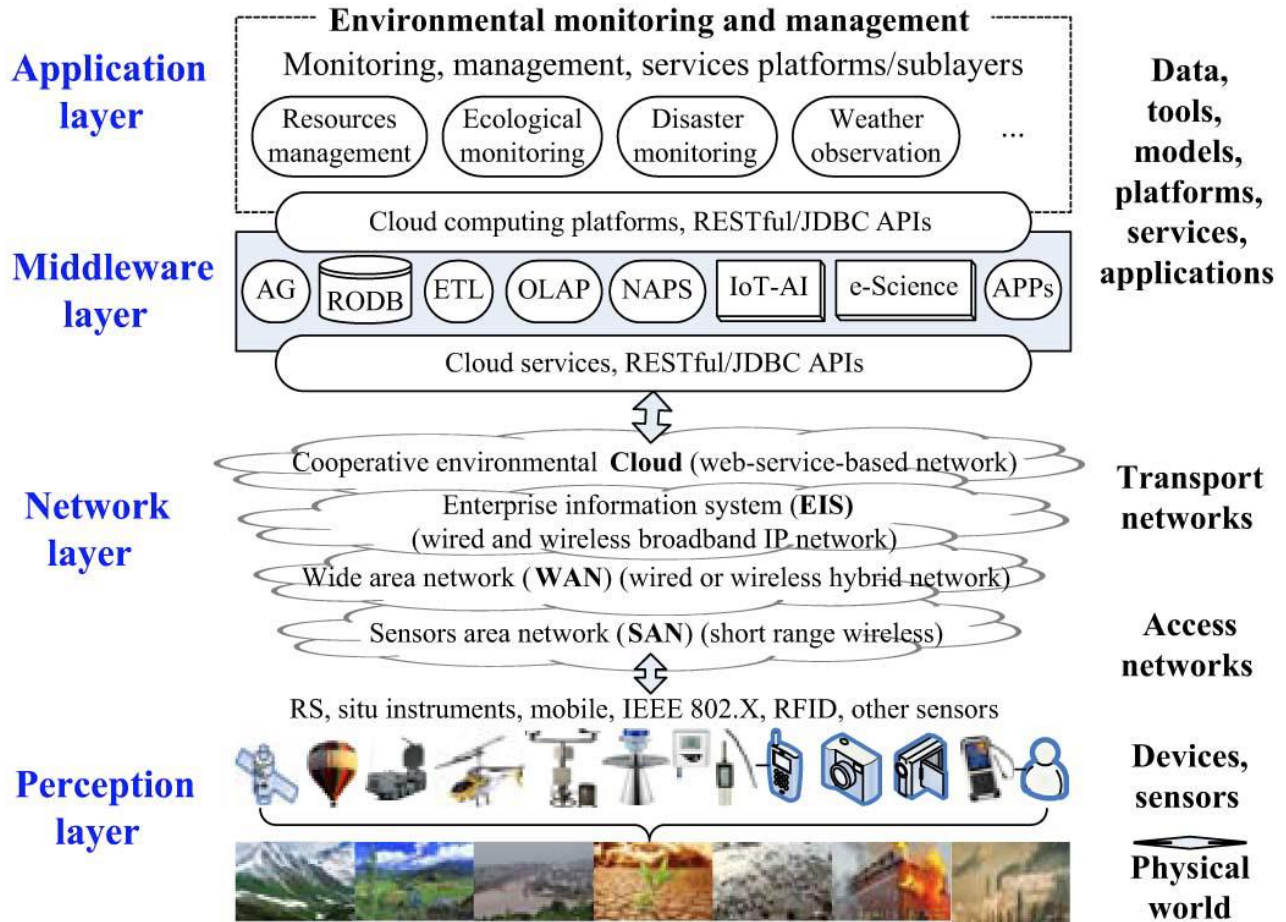

Figure 5: Overall architecture of the IIS based on IoT by (Shifeng, et al., 2014).

The prototype of this system was built on an architecture based on a four layered model as shown in figure 5. The section below explains how this architecture works:

## **A. Perception Layer**

This is the layer that carries out environmental data monitoring and management. It begins by collecting real time data by the use of multiple sensors and remote sensing platform. The remote sensing platforms use satellites, radar or even air crafts. Situ instruments are also used to obtain the ecological, hydrological, and meteorological factors. The layer uses communication methods such 3G, Bluetooth, ZigBee, Wi-Fi and RFID, and other sensors (Shifeng, et al., 2014).

## **B. Network Layer**

This is the layer that allows for data and information transmission. It interconnects different platforms and all the systems involved through the use of access and transport networks.

Access networks are also viewed as wireless networks and are made up of 2G, SAN, 3G, WiFi, and ZigBee which supports the connection of the smart objects such as the sensors, microcontrollers, actuators devices and the users participating in environmental monitoring and management.

Transport networks on the other hand consist of Wide Area Networks that can either be wired, wireless or hybrid. They are subsystems of EIS with wired and wireless broadband Internet Protocol network and EISs could be connected to the cooperative environmental cloud with web service based global network (Shifeng, et al., 2014).

## **C. Middleware Layer**

This is the layer that consists of sub layers used for data, software, models and platforms management and also acts as the interconnection between the network layer and the application layer.

RODB also resides in this layer and is used for efficiently managing large amounts of data collected by the sensors and other devices. The database also stores and manages models, knowledge, and other related information. (Shifeng, et al., 2014).

## **D. Application Layer**

This is the top most layer and consists of application support platforms, cloud computing platforms, e-science platforms and other platforms. This layer provides an interface for visualizing and accessing the data and other information obtained from the sensors and other objects. The Application layer uses displays such as LCD and web site for the access to information.

## 2.5.2. Vehicular Pollution and Status Monitoring Using RFID

In this research work, (Rajalakshmi, Karthick, & Valarmathy, 2015) explored the use of IoT in monitoring vehicular pollution using RFID. The system is build based on architecture as below:

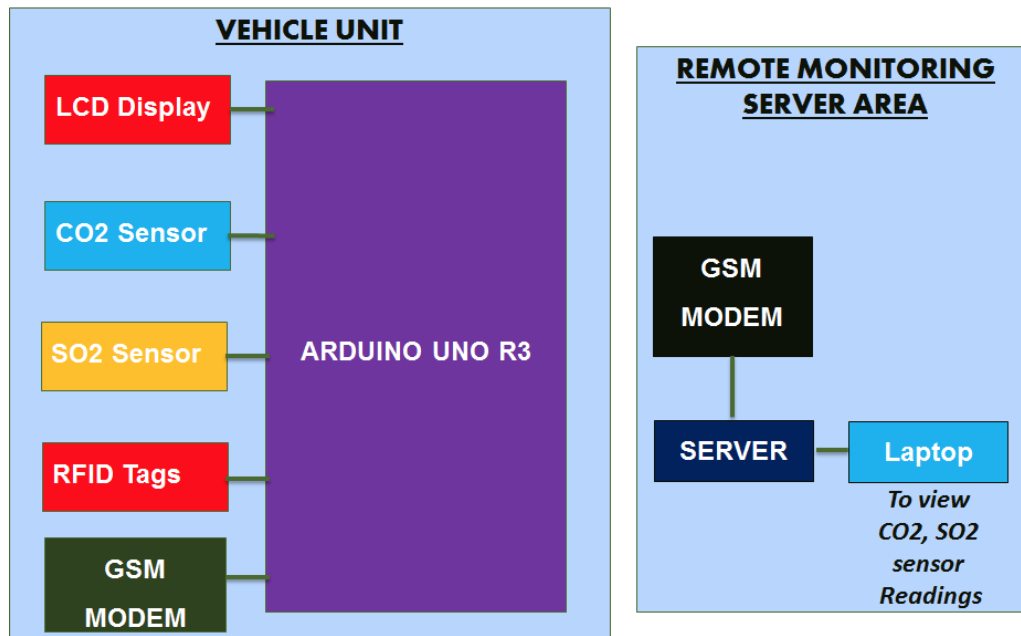

Figure 6: Vehicular Pollution and Status Monitoring by (Rajalakshmi, Karthick, & Valarmathy, 2015)

The architecture is divided into two parts i.e. the first part is the vehicular unit and the second part is the remote monitoring unit. The element contained in each section is as shown in figure 6. (Rajalakshmi, Karthick, & Valarmathy, 2015).

### A. Embedded System Platform

The main elements of this system includes embedded system platform on Arduino Board with ATmega 328 and GSM modem.

### B. Arduino Uno R3 Board

The project used Arduino Uno R3 as the microcontroller and is shown in figure 7.



*Figure 7: Arduino UNO Board*

The Arduino board provides a set of digital and analog I/O pins that can be interfaced to various extension boards such as the breadboard and other related circuits. The board has several interfaces such as the serial communication interfaces, connection and data transfer interface such as the USB which can be used for transferring data to and from a computer as well as for loading programs from PCs and programming the module.

The board is programmed through an IDE and supports several programming languages such as C/C++, java and python based on the project one is undertaking. (Rajalakshmi, Karthick, & Valarmathy, 2015).

### **C. GSM Modem**

The work of GSM modem is for sending data in form of short messaging, making and receiving calls. The modem is connected to the microcontroller through the standard RS232 serial interface that allows it to be easily connected to the computer.

It is also a plug and plays device that if controlled through AT commands via a computer or other through other displays such as LCD. The GSM modem also has SIM300 module to control its operations. This module also carries out functions such as power regulation, holding the SIM card and external antenna to enhance the network. (Rajalakshmi, Karthick, & Valarmathy, 2015).



## GSM Modem



*Figure 8 GSM gas sensor*

### **D. CO2 sensors**

This sensor is easy to use and can be easily incorporated in a small portable unit. It has sensitive layers built on polymer. This gas sensor has the advantage of using low power consumption and can easily fit into microelectronic-based systems. (Rajalakshmi, Karthick, & Valarmathy, 2015)



*Figure 9 CO2 Sensor*

### **E. GAS sensors**

The gas sensors used in this research are the MQ gas sensors. They are also simple to use and are cheap but effective and useful for sensing gases in the air. There are several types of gas that detects specific gases such as Nitrogen Dioxide, Carbon Monoxide, Methane, Sulphur Dioxide, LPG, CNG, smoke and Alcohol. (Rajalakshmi, Karthick, & Valarmathy, 2015).

### 2.5.3. Air Quality Monitoring based on Mobile Sensing

In this study, (Srinivas, et al., 2013) developed an air quality monitoring system capable of providing real time data. The areas of air quality monitoring included metropolitan areas. In this study, vehicular-based approach was used where the IoT devices mounted in mobile vehicles was used for measuring fine-grained air quality in real-time. The system used two cheap but effective data farming models: The first one was deployed in public transportation and the second one was implemented as a personal sensing model thereby allowing people walking around to collect data via the devices they possess.

These are described as below:

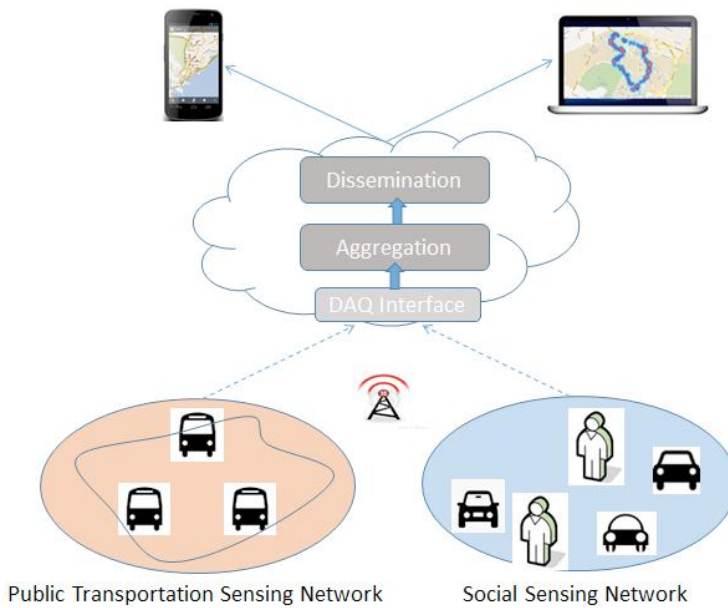

Figure 10: Real time air quality monitoring by (Rajalakshmi, Karthick, & Valarmathy, 2015)

#### i. Movable sensing Model

This is the mobile sensing that is deployed on the public transportation. The public transport used can be buses, taxis and trains. These public transportation provides the capability of obtaining data from varied as well as fixed locations. They therefore measure data from reliable routes and at frequently during their operations. In this mobile sensing model, a custom made Mobile Sensing Box (MSB) was used. This box is equipped with a microcontroller board and a series of gas connections to the microcontroller board. The box also has a GPS receiver connected in

periphery as well as a GSM modem. The box receives its power from the battery used by the vehicle. (Srinivas D. , et al., 2013).

In this research, two gas detectors were used. The detectors therefore detected carbon monoxide and particulate matter concentrations. (Srinivas D. , et al., 2013)

## **ii. Personal Sensing Model**

This model is aided by the help of drivers who are referred to as “air quality-aware drivers”, they install the personal sensing devices in their cars and connected the PSD to their smartphones via a Bluetooth. This therefore allows the drivers to set up and measure air quality data for themselves. They can also come together and participate in community sensing. The pollution data they collect is geo-tagged to locations. The data is sent to the central storage server via a cellular network where it is processed and made accessible. (Srinivas D. , et al., 2013).

#### 2.5.4. Air pollution monitoring based on WSN

In relation to this study, (Jiachen, Jianxiong, Zhihan, & Houbing, 2015) carried out a Comprehensive out a study by implementing and comparing air pollution monitoring systems build by WSN. The three types of Sensor networks that were studied are: these, three types of sensor networks were studied namely: Static Sensor Network (SSN), Community Sensor Network (CSN) and Vehicle Sensor Network (VSN).

##### i. SSN

Static Sensor Networks makes use of sensing nodes that are mounted on streetlight distributed across a geographical area. Some sensor nodes are also mounted on traffic poles or on the walls and billboards. see Figure 8.

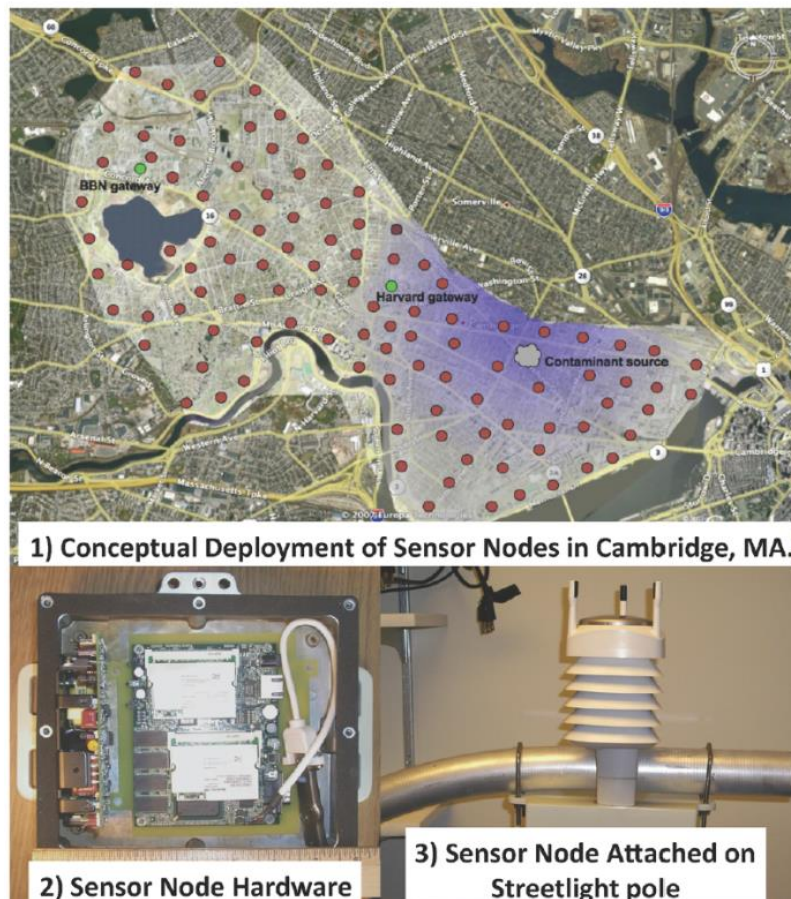

Figure 11: Static Sensor Network (Rajalakshmi, Karthick, & Valarmathy, 2015)

The scalability of this system can be enhanced through the utilization of low-cost sensors, the number of these sensors will therefore be much larger than the number of sensor nodes in the conventional monitoring systems. The authorized and processed air quality information is made available to the public through web pages, websites, mobile Apps. (Jiachen, Jianxiong, Zhihan, & Houbing, 2015).

**ii. CSN**

This is also known as Participatory Sensing systems where the sensor nodes are typically carried by people (see Figure 9). This sensing model also utilizes low-cost portable ambient sensors and the ubiquitous smart devices. The participating community of users is able to collect, analyze and share their local air pollution data. (Jiachen, Jianxiong, Zhihan, & Houbing, 2015). The data is also made available to other users through websites, mobile application etc.

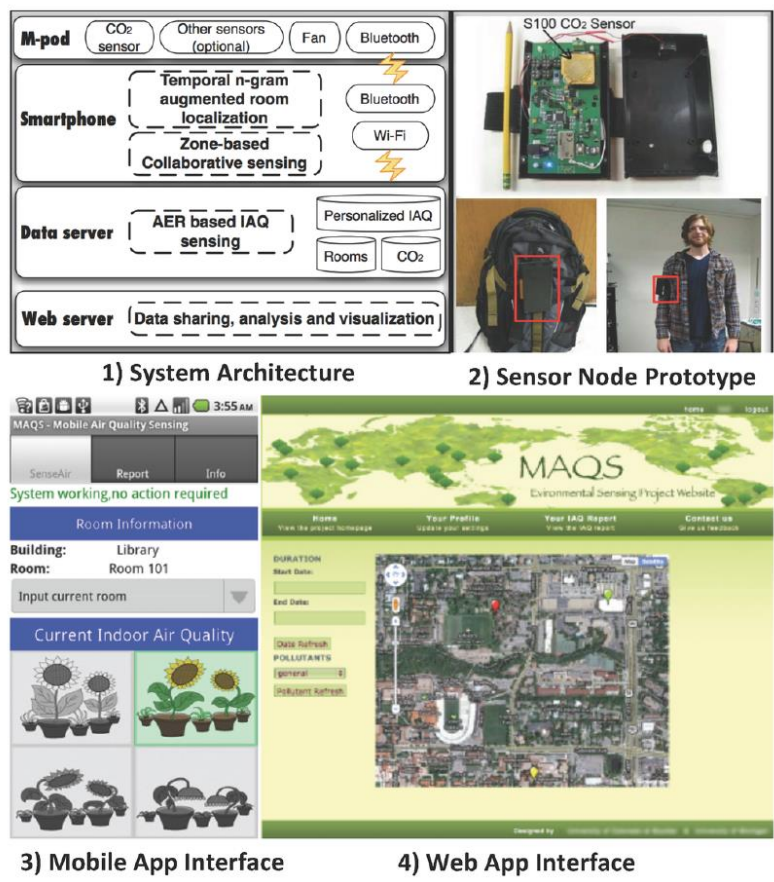

Figure 12 Community Sensor Network (CSN) (Rajalakshmi, Karthick, & Valarmathy, 2015)

iii. VSN

In this model, Sensor are mounted onto the public transportation such as buses or taxis (see Figure 10). The system utilizes low-cost portable ambient-sensors and makes use of the mobility of the vehicles. A single sensor is capable of collecting data from a large area of Geographic coverage (Jiachen, Jianxiong, Zhihan, & Houbing, 2015).The data is also made available to other users through websites, mobile application etc.

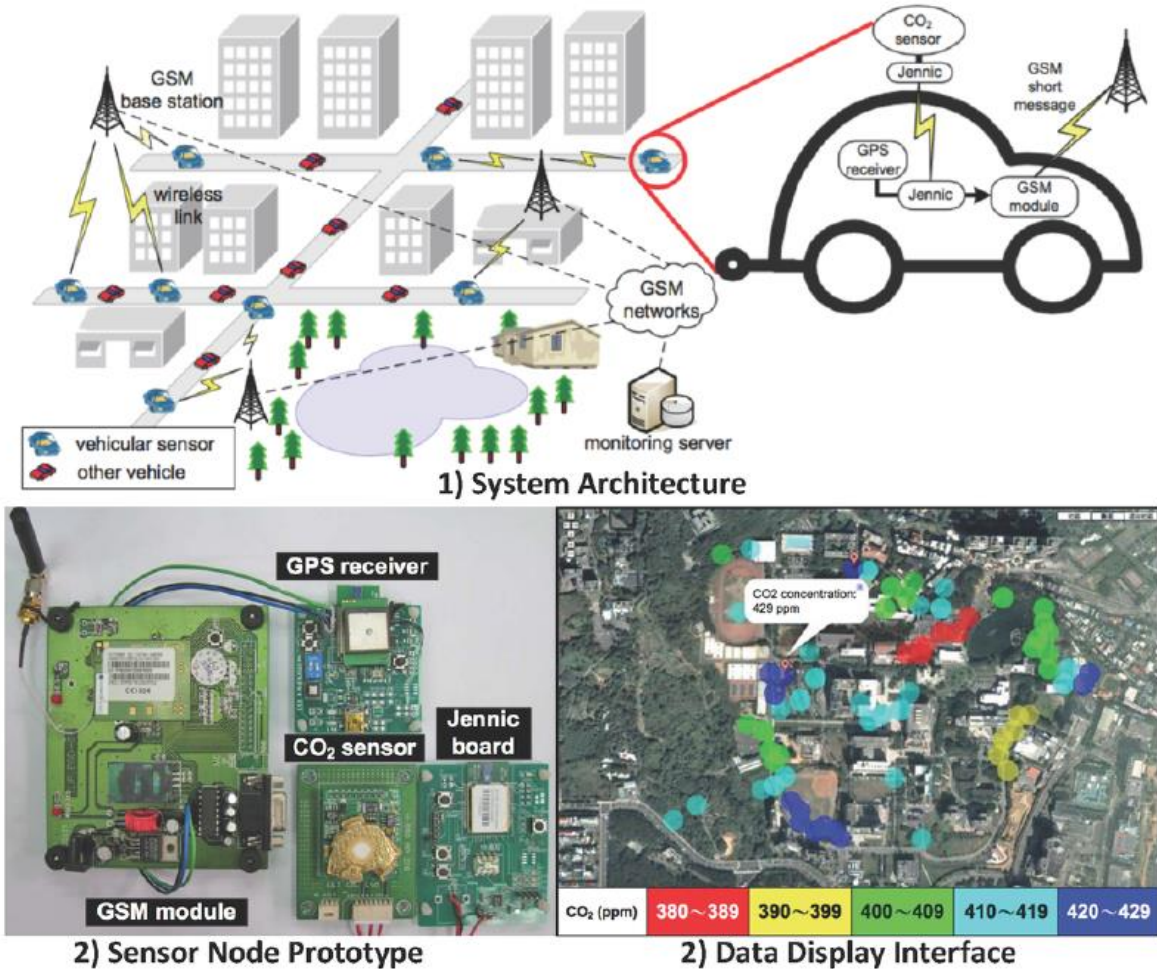

Figure 13 Vehicle Sensor Network (VSN) (Rajalakshmi, Karthick, & Valarmathy, 2015)

## 2.6. The proposed approach

In this section, architecture was proposed. The general reference framework model for the design of an IoT enabled air quality monitoring architecture was then discussed into detail. The specific characteristics of an IoT enabled air quality monitoring system, and the services that may drive its adoption of urban IoT by the local governments were also examined.

The research also carried out an overview of web based technologies and how their design can be used in achieving IoT communication services. Further, related protocols and technologies were also studied as well as discussing their suitability for the air quality monitoring systems in Kenya.

From the analysis of the examples of the enabling technologies and architectures in the above sections, it clearly emerged that most IoT based systems are built on centralized architectures. The smart objects and the heterogeneous set of peripheral devices are therefore deployed over a wide area to collect different types of data that are then delivered through the most suitable and readily available communication technologies to a central storage area for data storage and processing.

The proposed system architecture in this study was based upon previous work on environmental monitoring system described in (Zhihong, et al., 2011). The architecture was based on the IoT enabled Environmental Monitoring System and WSN.

Modifications have been done on the original architecture for the purpose of testing this model, for example sophisticated servers have been replaced by a laptop that will be used for the experimental purpose but at the same time is expected to give accurate results as will be in the case of real server environment.

This architecture also proposes to carry out the experiment in a layered approach mainly

- server-end layer (server layer)
- communication and data storage layer and
- Sensing and connectivity layer (mote layer) as implemented in (Ghobakhlou, Zandi, & Sallis, 2011).

Below is the proposed architecture:

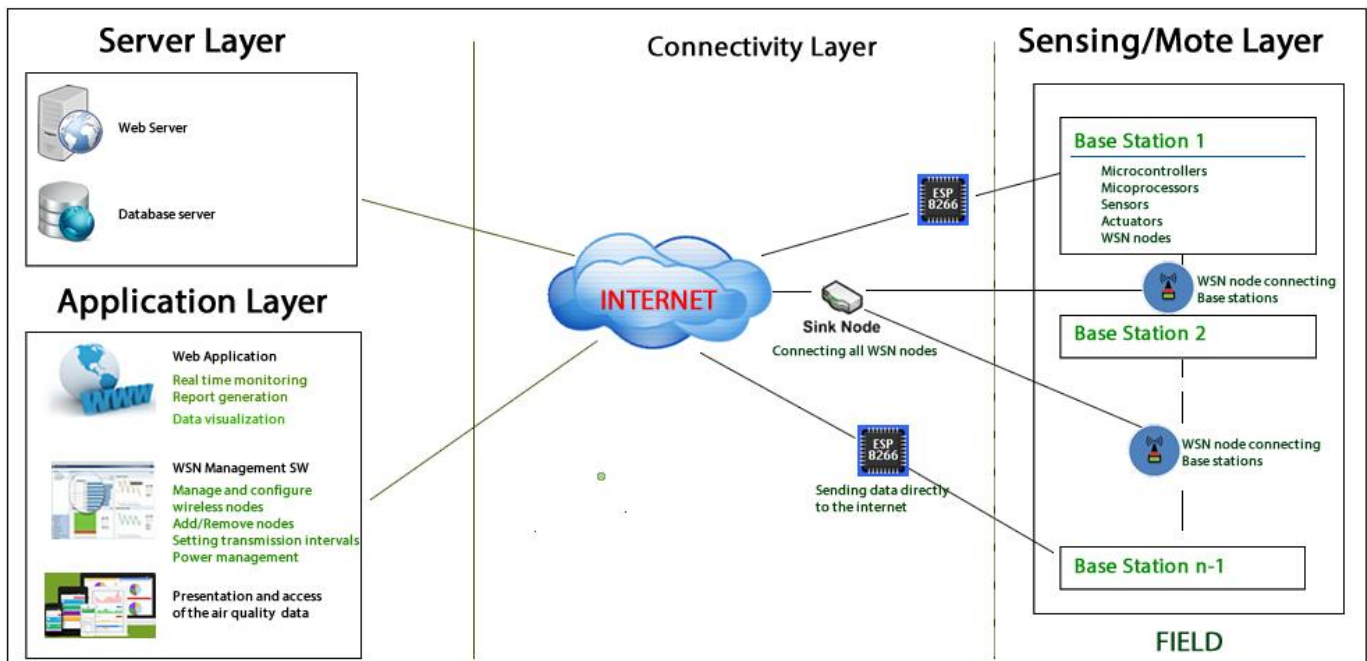

*Fig: Proposed IoT architecture for implementing the air quality monitoring system in Nairobi County.*

The system based on this architecture consists of Nodes/Mote layer that is composed of objects for collecting environmental data. These objects are integrated as base stations containing sensors, microcontrollers, and other devices such as the WSN nodes. The base stations are then mounted on structures such as buildings, billboards and street light poles. The communication node enables the data to be transmitted to other WSN nodes. All these data is converged to a sink node that can send the data collectively or individually to a central server via WSN gateway unit. This air quality monitoring system shall make it possible to collect air pollution parameters such as Carbon monoxide levels, Methane, LPG, Smoke, Cyanide Gas and Alcohol. These layers are reviewed as below:



### **A. Sensing and connectivity layer**

This is the layer where the IoT wireless sensor nodes assembled into a base station will be placed. The base stations will be mounted on different structures such as street light poles that are geographically distributed within and out of the city.

The nodes in these base stations will then be uniquely be identified and mapped to provide accurate context information of the node. The nodes are will be powered by though connection to the power source of the lighting used in the different objects they are mounted in such as the power for the billboards, street lights and the CCTV cameras.

### **B. Communication layer and data storage**

This is the layer that will ensure the transmission of data from the notes to the central storage as well as ensure that the data processed from the server end layer reaches the intended audience. In order to allow low-power transmission of data from the nodes to the server, constrained link layer technology such as 6LoWPAN will be used.

### **C. Database server**

The database server will be used for storing sensor data that has been collected. It will also allow a rapid access to the data as the data needs to be accessibly in a timely manner. This access can be achieved through HTTP-Constrained Application Protocols proxy server. The proxy server ensures that retrieving the needed data is obtained from proper source. Once the data is stored in a database, it can be easily accessed through the web programming tools. The processed data will then be processed and stored in the database that is accessible through web interfaces. The information can also be used across different platforms by the use of api's . The information can be visualized in the form of graphs, charts and can then be accessed via web interfaces in form of open data formats.

### **D. Server-end layer**

This is the layer where servers will be hosted. The servers will include web servers, file servers and will be used for host databases and all the data from Arduino IDE as well as the contents of the sensor readings. In order to allow the data to be accessed to the public, a public IP address will be used to allow for remote access.

# **CHAPTER THREE**

## **RESEARCH METHODOLOGY**

### **3.1. Research design**

Research design is the overall plan a researcher chooses in order to integrate the different elements of a study in a coherent and logical way. This ensures that the research will effectively address the research problem. Research design therefore entails data collection, data measurement and data analysis, (Maxwell & Joseph, 2012). The design is closely associated with the framework of the study and guides planning for implementing the study.

This research work employed a case approach in achieving its objectives. Researcher (Yin, 1984) defined case study research method as an empirical inquiry that investigates a contemporary phenomenon within its real-life context; when the boundaries between phenomenon and context are not clearly evident; and in which multiple sources of evidence are used. (Zainal & Zaidah, 2007)

The case study approach involved an investigation of the current air quality monitoring systems used by the environmental authorities in Kenya in obtaining air quality data as well as studying different cases where IoT enabled air quality monitoring systems have been developed and are being used to obtain air quality data. The environmental authorities that were investigated included Kenya meteorological Department located in Ngong road, UNEP located in Gigiri and NEMA located in Mombasa road.

In regards to obtaining information about the air quality monitoring system implemented by NEMA and KMD, a case study was carried out at Dagoretti base station, a project that was collaboratively implemented by NEMA and KMD. In this study, Interviews, Observation document analysis and Questionnaires were used to collect data. The data provided information about the current air quality monitoring system that is currently used in Kenya to obtain air quality information.

Another case study was carried out on UNEP's air quality monitoring system. The study location was UN Complex in Gigiri. In this case study, data was collected through interviews, questionnaires and document analysis. Real time data was also obtained from the air quality

monitoring system from UNEP in order to provide vital data for comparison with the system prototype implemented in this research.

Finally, an air quality monitoring system prototype was developed. The system prototype was based on an architectural design proposed in this research. The data for this prototype was collected through an experimental design where the developed system prototype was run in different locations at UN complex in Gigiri as well as at the IBM research center in Catholic University. The data collected from these locations were recorded analyzed and compared to the data that were obtained by the other air quality monitoring systems.

### 3.2. Designing the air quality architectural model

After studying several architectural models used for designing IoT enabled air quality monitoring systems, a three-layer architectural model by (Ghobakhlou, Zandi, & Sallis, 2011) was seen as suitable and was therefore adopted for this research. Figure 14 shows the three layered architecture.

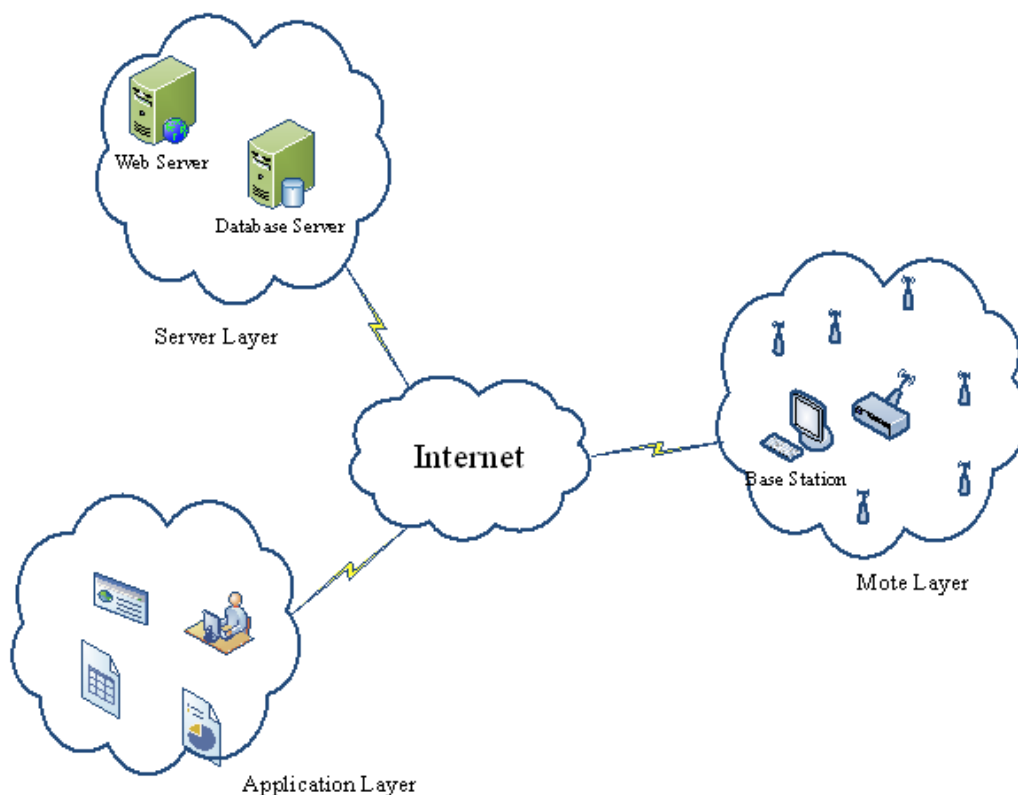

Figure 14 System architecture adopted from (Rajalakshmi, Karthick, & Valarmathy, 2015)

**Mote layer:**

This layer consists of a series of wireless sensor nodes, microcontrollers, gas sensors and all other tools assembled together into a Base Station. The base station is therefore a package of nodes and other devices such as a transmitter, a power supply and microcontroller. The microcontroller in this case is an Arduino board and it uses a bread board to interface with other elements being used in the study.

Each base station containing the nodes is then installed in different locations where the data will be obtained. They are therefore placed uniquely to be able to collect data from different areas. They are also carefully placed to ensure that the distance between the wireless sensors nodes used for transmitting the information to the next base station does not exceed the maximum radio frequency communication range. The system also uses energy optimized routing to optimize the communication of the nodes. (Ghobakhlou, Zandi, & Sallis, 2011)

**Server layer:**

This is the layer that stores all the sensor data. The data from the nodes in each base station are transmitted to the central storage server via the internet. The collected data can also be manually transferred to the server in case of a connection failure through the use of USB cables. The server is therefore able to receive and process data from the base stations, populate the WSN data and send the data to the application layer for visualization. (Ghobakhlou, Zandi, & Sallis, 2011)

**Application layer:**

This is the layer that is used for accessing the air quality data once it is processed and visualized. The application layer also allows the administrators access the wireless sensor network data remotely through the use of interfaces such as the web browsers. This provides the administrators with powerful tools for visualizing real-time wireless sensor network data as well as carrying out comparison of the data collected from other nodes. The application layer allows the administrators to access the base stations remotely and be able to modify sensor nodes' configurations. (Ghobakhlou, Zandi, & Sallis, 2011)

### 3.3. Designing the air quality monitoring system

#### A. System Overview Section

The overview of the system is described in figure 13. All environmental sensors act as input and connected to a micro-controller i.e. an Arduino Uno R3.

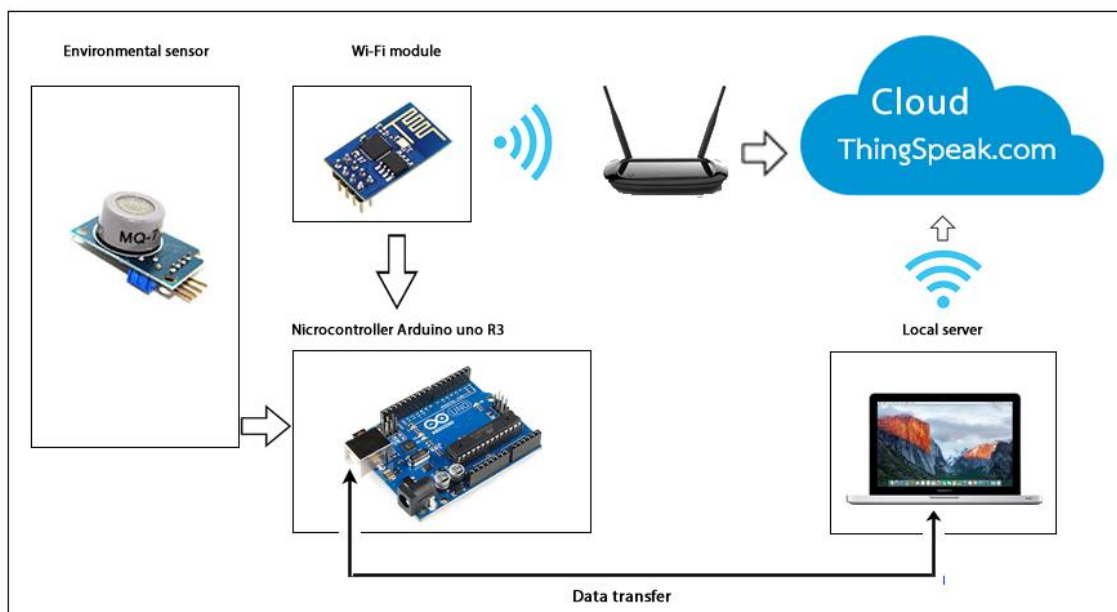

*Figure 15: System Overview*

The sensors are organized in a breadboard. The other tools used include a Wi-Fi module to connect to Wi-Fi to enable the data from the nodes to be sent to the web-server. The output of this system is visualized data that is sent to cloud and can be accessed via electronic gadgets such as personal computers, smart phones and other hand-held gadgets.

## B. Electrical Section

Electrical component of this prototype consists of seven gas sensors such as MQ 2, MQ 7 carbon monoxide sensor, a Wi-Fi module ESP8266, resistors, Linear regulator and LED's. The sensors are connected to the microcontroller i.e. Arduino Uno R3 via an expansion board (bread board).

By using the breadboard, all sensors and other nodes will get power identically and the voltage to these nodes will be 5V. However, it is not recommended to directly connect ESP8266 with Arduino because Arduino speaks in 5V and may result damaged in both sides. Therefore, 3.3 V linear regulator is used to decrease the power from Arduino. The schematic circuit is shown in figure 14. Figure 14 also shows how the gas sensors are connected to the microcontroller.

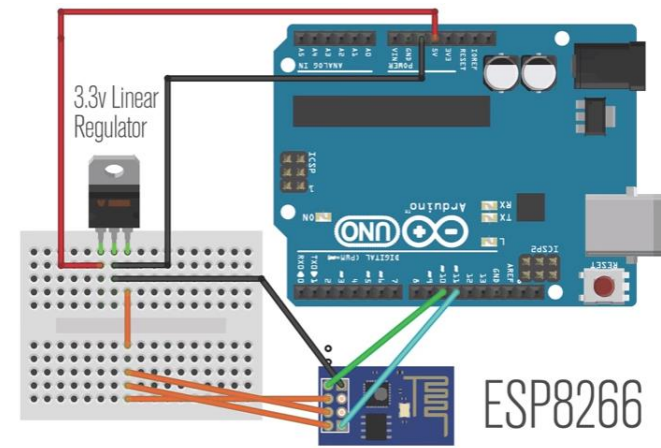

*Figure 16: Electrical System*

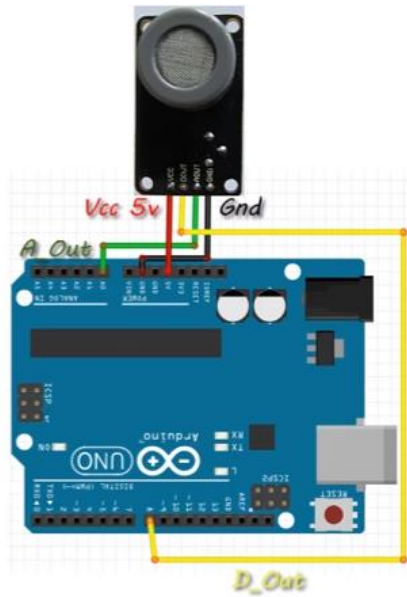

*Figure 17: Sensor connection to Arduino*

### **C. Software Section**

The softwares used in this system are mainly for communication between the nodes and the servers for data processing, visualization and data access. There are two communication methods that can be used in this research.

The first is the use of Serial0 for direct communication between Arduino and PC and the second method is the use of Serial1 for communication between Arduino and ESP8266 Wi-Fi module to transfer data to the server via web-server. In this research, thinspeak.com webservice was used for prototype purpose. Here are many open source systems that are readily available and can be developed to allow the nodes to send the sensor data directly to web-servers.

Another important function of this section is the ability to view the data from the sensors either before or after it has been processed into information. The data can be viewed locally in a

computer when the node is connected using a USB cable via Serial0 to the computer and the readings are viewed from the serial monitor of the Arduino IDE.

The data can also be viewed via a web server through the use of an IDE programme code that enables the data to be read from the node and sent to the web-server using the ESP8266 Wi-Fi module. In this case, the baud-rate of the module must be set e.g. at 115200 for Serial1 Serial0 can be set in any baud-rate. After baud-rate is set, the connection to Wi-Fi router must be set.

The Wi-Fi connection allows data transmission from the Arduino node directly to webservers using standard HTTP protocol. The communication between Arduino and ESP8266 can be tested using AT command. After the module is connected to Wi Fi, it will read all sensors data from analog input of Arduino. The data collected in Arduino must be converted to string hence it can be used to update data value on the web.

#### **D. Application layer**

In this prototype design, a web application is used to access the air quality data. The website used is [www.thingspeak.com](http://www.thingspeak.com). In this website, an account and a channel is created to get API key that is used for updating values from the nodes in visual form such as the use of graphs and charts. Communication between the board module and ThingSpeak is initiated by the use of AT command. The API's are generated in [thingspeak.com](http://thingspeak.com) and can be used in other interfaces such as mobile apps through the use of iframes.

Apart from sending the data to a free IoT webserver such as [thingspeak.com](http://thingspeak.com), the same data can also be sent to local database and webserver within the Local Area Network. The major difference is the IP address used, process of data acquisition and http request packet construction are remain the same.

### **3.4. Data collection**

In order to gain an insight of the current air quality monitoring systems in Kenya, data was collected by Questionnaire, Interviews and Analysis of documents. The responses from the interviews were then recorded and filled questionnaires given to the researcher. Narratives that were received after the data analysis was then used to confirm the findings. Data from the different cases were also collected through document analysis and documented under the findings session.



Data from the system prototype was also collected via an experimental approach. This was mainly to check the reliability of the prototype through comparison of the data with other tested systems and hence ascertain the suitability of the proposed architecture. Data taking by the prototype involved running the system in different locations and recording the readings of the air pollution data being tested. The node was therefore placed in selected areas and data was collected within an interval 5 minutes.

Figure 17 shows the prototype that was used in collecting the air quality data in the selected locations.

### **Development Kit Prototype**

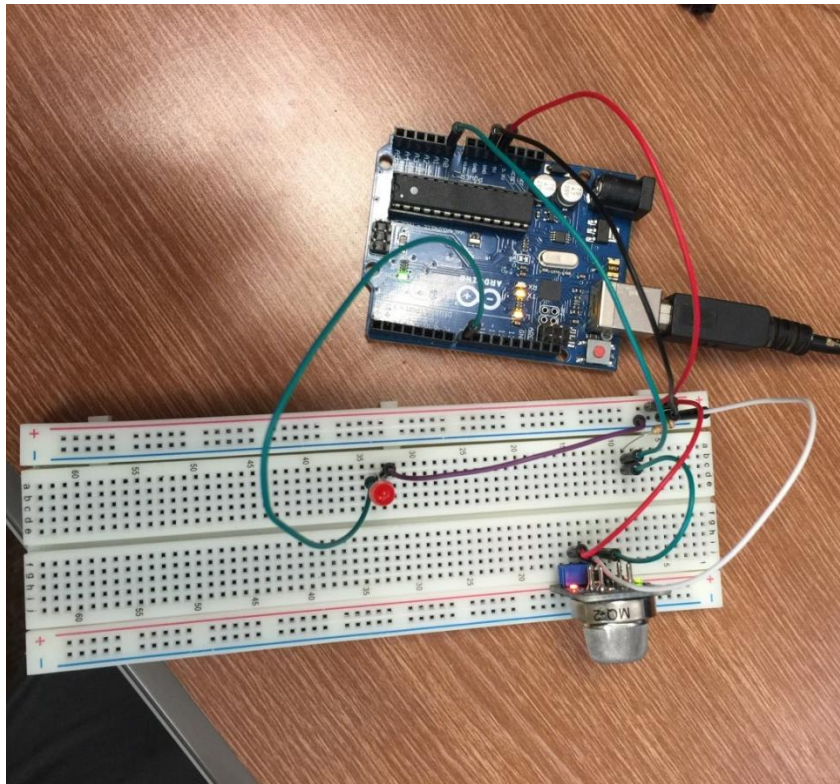

*Figure 18: Development Kit Prototype*

### **3.5. Data analysis**

Data analysis involves undertaking various steps that are outlined in a qualitative research. (Graneheim & Lundman, 2004). These steps include identifying a theme, verifying the identified theme through examination of the data and discussing these data with other researchers or the practitioners in the field of study. The last step involves categorization of the the theme as well as the documentation of relevant data of the theme.

In this research data analysis will began by first checking the consistency and completeness of the data from the questionnaires. The data was then analyzed using descriptive statistics such as frequencies, percentages, central tendencies and presenting the results in tables, bar graphs and pie charts. Documents were analyzed by Tesch's methodology. In a study by Tesch, data segmentation and categorization is described. This involves carrying out data contextualization and de-contextualization to obtain an understanding of the variables under study. It begins by reading and re-reading all the documents for familiarization by the researcher. Once this is done, the researcher will be well aware of the types of data involved in the study.

Thereafter, segments or meaning units were identified. Finally the experimental data from the system prototype developed were checked for validity through comparison with the data that were obtained in the same location by tested systems.

# CHAPTER FOUR

## FINDINGS AND PROTOTYPE DESIGN

### 4.1. Introduction

This chapter presents the findings of the study based on the objectives of this research. An IoT enabled air quality monitoring system architecture for Nairobi city was proposed. This architecture is carefully designed based on the test cases where such systems have been implemented and the technologies proposed are those that can readily be implemented in Nairobi city. The architecture is then tested using a system prototype. The findings of this research are presented in the following section.

### 4.2. Air quality monitoring methods currently being used in Kenya

#### 4.2.1. Ozonesonde sounding system:

This method measures ground level ozone, vertical profile of ozone, total column ozone, and various weather parameters. Initially the system was run on a manual ozonizer test unit model KTU-2A (KTU) monitoring instrument. The KTU system operated based on the Vaisala RS80 radiosonde and the Electrochemical Cell (ECC) ozonesonde. In the year 2010, the Vaisala RS80 was upgraded to a new Vaisala RS92 Figure 18 and 19 that is now in operation.

This system is used in preparation of the ozonesonde on the day of launch and conditioning 7 days before the launch.. It facilitates measuring; vertical profile ozone, upper air data, amount of voltage in the batteries and the electric current generated. (Zablon, et al., 2015).



*Figure 19: Ozonesonde sounding system*

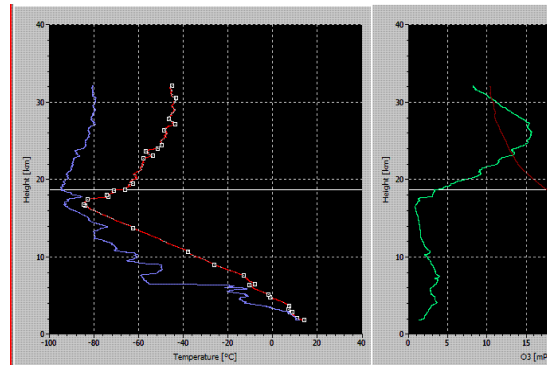

Figure 20: Generated data during flight

#### 4.2.2. Surface ozone analyser

The surface ozone analyser is Model 49i for sampling ground level ozone (Figure 3). The analyser uses the ultra-violet radiation based on photometric technology to detect the levels of ozone in the sample of air. The units for measurement in this case are in parts per billion (ppb).

The analyzer has two interfaces where photometers with both sample and reference air flows in and out at the same time. The Surface ozone data is measured and monitored continuously and the data is captured and recorded after every five minutes. The analyser in Nairobi, at Dagoretti, is in a laboratory room with a rain proof air inlet directed outside at a distance of 10m above the ground. (Zablon, et al., 2015).

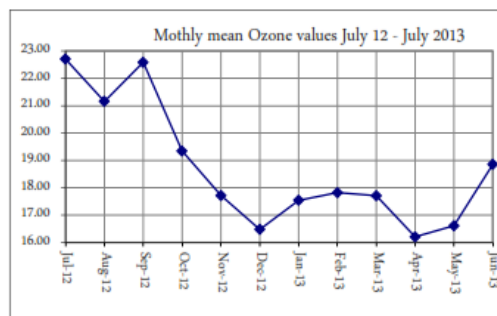

Figure 21 Results from the ozone analyser (Zablon, et al., 2015).



Figure 22: Surface ozone analyser (Zablon, et al., 2015).

#### 4.2.3. Dobson spectrophotometer – Column Ozone

In the Nairobi, station there is installed the Dobson Spectrophotometer No. 18 column ozone measuring instrument since 2005 (Figure 17). This instrument was initially at Chiromo campus at the University of Nairobi where WMO installed it in 1984 and was in operation until 1996.

A ground-based instrument that measures the total ozone present in the atmospheric column by estimating the ultraviolet radiation (UV-B and UV-C) which calculate how much ozone is present in the entire atmospheric column (Zablon, et al., 2015).

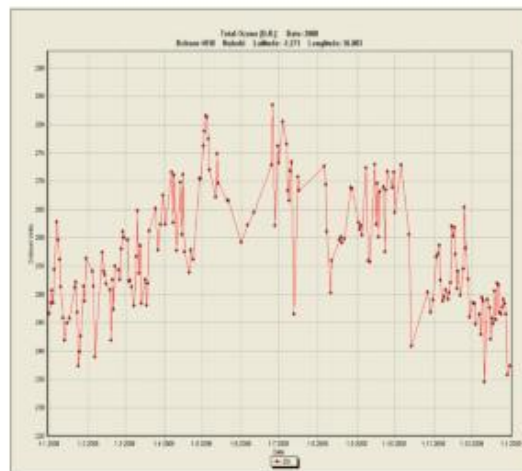

Figure 23 Dobson and its sample data set (Zablon, et al., 2015)

#### 4.2.4. UNEP Air Quality Monitoring System

The UNEP Air Quality monitoring system is composed of Optical Particle Counter for detecting PM1, 2.5 and 10 that carries out the collection of samples in an interval of 2 seconds. The unit also has two gas sensors that detect Sulphur dioxide and nitrogen dioxide. It also has Global Positioning System for mapping the data location to the devices. Also, the unit has temperature sensor, humidity sensor and a microcontroller, the microcontroller in this case is a Texas Beagle Bone data controller.

This system provides the ability to add more sensors such those that can detect ozone and Volatile Organic Compounds. The power source for this system is a 12 volts battery and can also be used for the mobile unit.

For data transmission, the unit uses 3G as the network and this is designed to operate as nodes within the network and therefore allow the inter-calibration. (UNEP Air Quality Monitoring System (2015, September 21). Retrieved from:

[http://uneplive.unep.org/media/docs/news\\_ticker/Air\\_Quality\\_Leaflet\\_Letter\\_size.pdf](http://uneplive.unep.org/media/docs/news_ticker/Air_Quality_Leaflet_Letter_size.pdf))

It should be noted that this air quality monitoring system can be deployed in distributed location owing to its rugged design. The system can also transmit real-time data meteorological stations, county offices and other national offices via wireless networks and telecommunication networks or data can also be obtained manually offline by connecting PC to the system.



*Figure 24: UNEP Air Quality Monitoring System (DEWA)*

### **4.3. Locations of the equipment and tools used for air quality monitoring.**

The instruments are located at the following sites; Dagoretti - Nairobi, Jomo Kenyatta International Airport, Chiromo campus - University of Nairobi, Mt Kenya GAW station and San Marco Equatorial Site.

The later station is now not operational and has remained dormant for a long time. Another key installation is the state of the art Mobile Air Monitoring Laboratory (MAML).

### **4.4. Cost of the tools and equipment's in terms of purchase, operation and maintenance**

From the data gathered from the records of the United Nations Environment Programme and the information obtained through a face to face interview, it was revealed that the cost of designing the air quality monitoring system by UNEP is approximately USD 1500 per unit. The unit is able to measure particulate matter and the main pollutants such as Sox, NOx, and Ozone. It is also able to provide details such as location. When the unit is calibrated, it is able to provide additional measurements such as temperature and humidity.

Compared to other air quality monitoring systems, the cost for the UNEP's is relatively low. The other typical national network systems cost approximately USD 100,000 – 200,000. This would be in contrast to the current systems high-precision instrumented station that costs approximately 250,000 US dollars.

### **4.5. How the air quality data disseminated to the public.**

The resultant data from the interview and open ended questionnaire to the environmental authorities generally revealed that the air quality information is not readily available to the public and is therefore only available upon request.

Other types of information such as weather forecast are readily available and are more emphasized than the air quality information. The information is only available in websites and mostly in the archives sections and is not regularly updated.

#### **4.6. Frequency with which these air quality information is availed to the public**

An open ended question, followed by a face to face interview to the environmental authority was asked to determine the frequency with which the air quality was disseminated to the public.

The findings revealed that the information about air quality is not readily available to the public domain and is therefore only available to health practitioners who take part in determining the level of air quality.

For those in need of the air quality information, they have to make an enquiry or get the data from the reports that are produced once in a while regarding air pollution and air quality.



## 4.7. Results from the Development Kit Prototype

### 4.7.1. MQ-2 Sensor Calibration Result

A schematic diagram as below was used for this experiment.

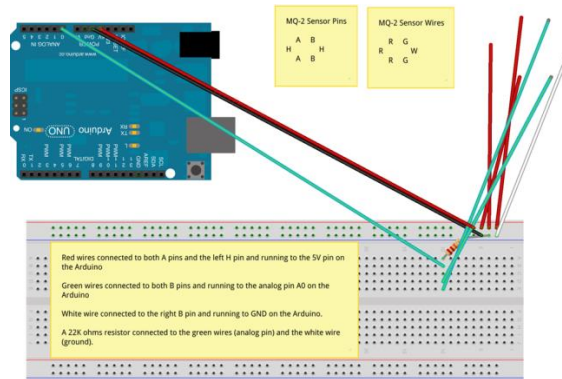

*Figure 25 Connecting MQ-2 gas sensor to Arduino and breadboard*

It is important to carry out the correct wiring connection.

The MQ sensor has pins grouped into three i.e. A pins, B pins and H pins. The A pins and the H pins must be connected to 5V.

The B pins must be connected to the analog input (A0).

The right H pin needs must be connected to the ground GND.

A load resistor between 2kOhm to 47kOhm can to be connected to both the analog input and the ground. In this case a 22kOhm resistor was used.

Test result of light sensor calibration is shown in figures 26, 28 and 30. The results were obtained from three different areas.

a) Sensor readings between blocks N and S at the UN Complex.

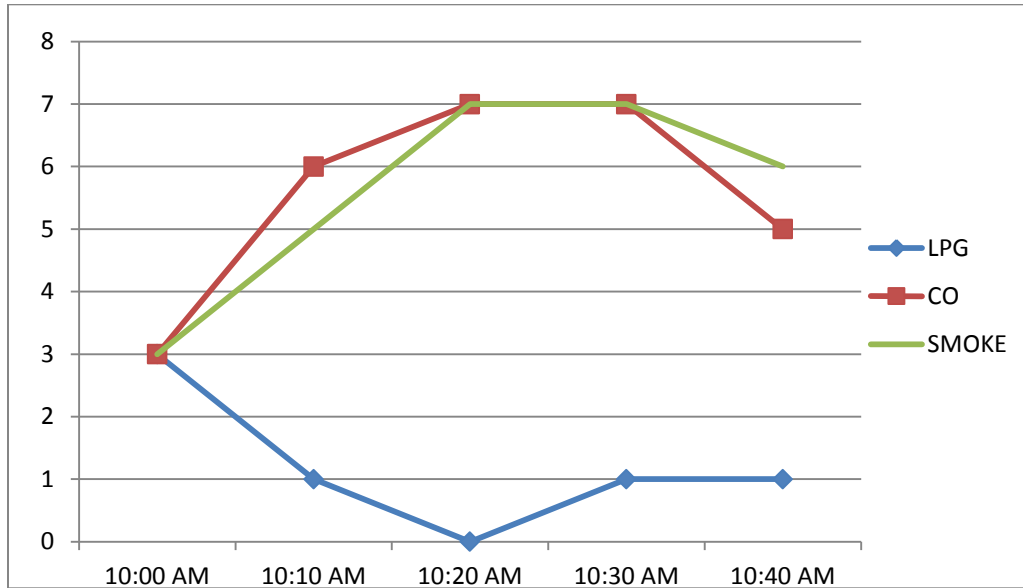

*Figure 26: Air quality data between block S and N*

The data obtained between these blocks shows that in this area, there was minimal level of carbon dioxide. However, due to the fact that there is a smoking zone, when the sensor was moved to this point, the readings of CO and smoke were seen to rise rapidly. The readings can be seen as accurate compared to the ones that were taken by the Air Quality monitoring system by UNEP.

The results from the UNEP's air quality monitoring system in the same location are as below:

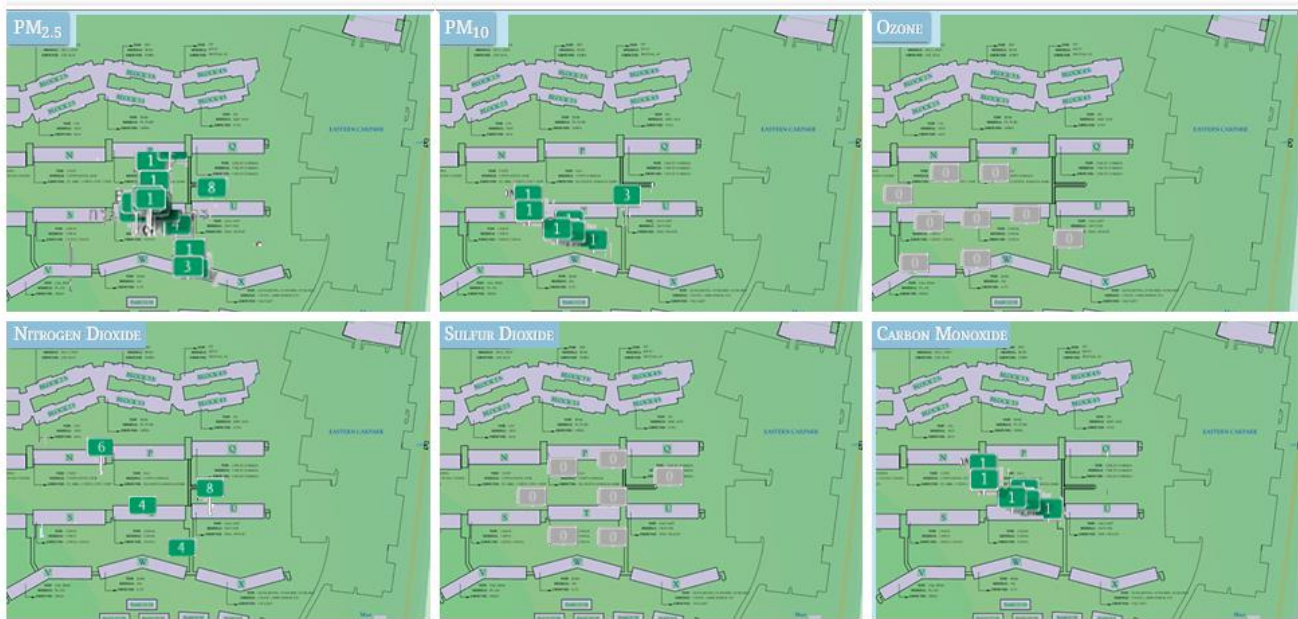

*Figure 27 Results from UNEP's air quality monitoring system between block N and S*

**b) Sensor readings between blocks N and S at the UN Complex.**

Further reading was taken in the delegates parking area at the UN complex and the data is as shown in figure 25.

The readings shows that the levels of CO is much more than the previous readings between blocks S and N. However the levels might not have been high due to the fact that there w less activity in this areas as the cars are parked long term with little movement of cars coming in and going out. The sensor also captured an increasing level of CO when the sensor was moved closer to a vehicle that was just parked.

These results can be seen as accurate as they were also compared to the readings from the UNEP's air quality monitoring system as shown in figure 26.

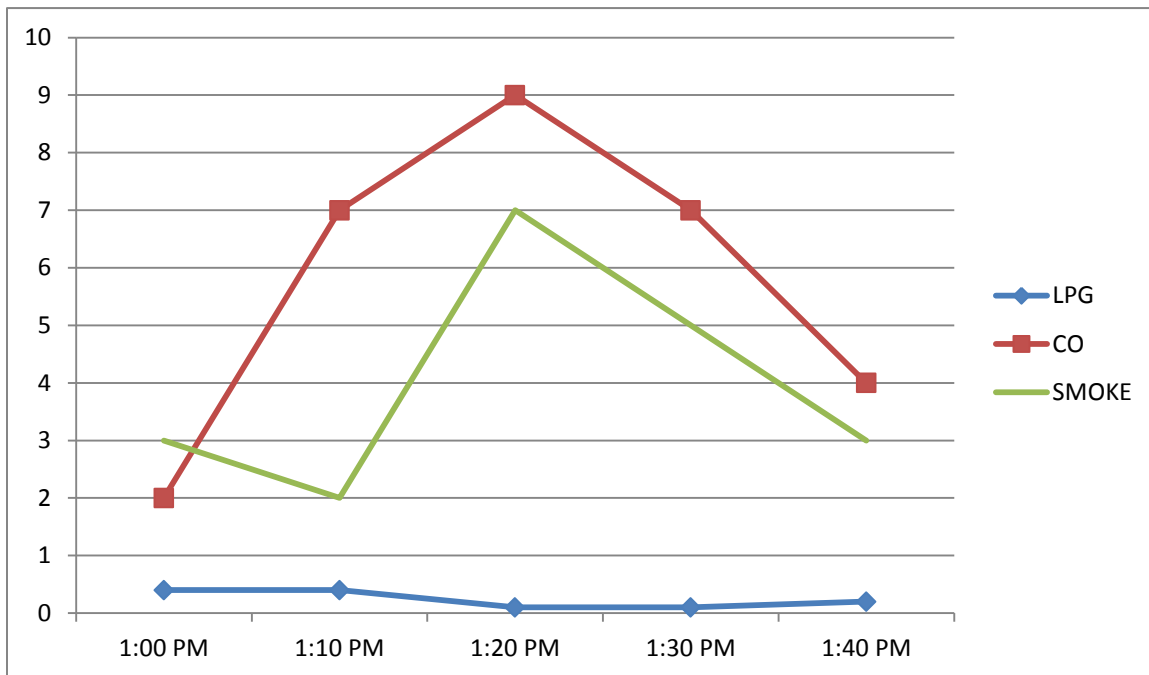

Figure 28: Sensor data readings at the delegates parking area

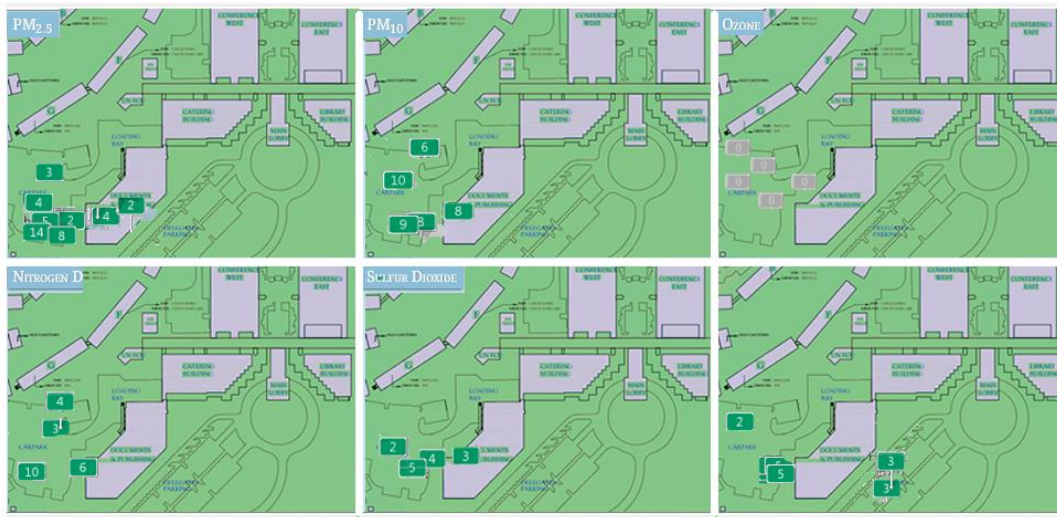
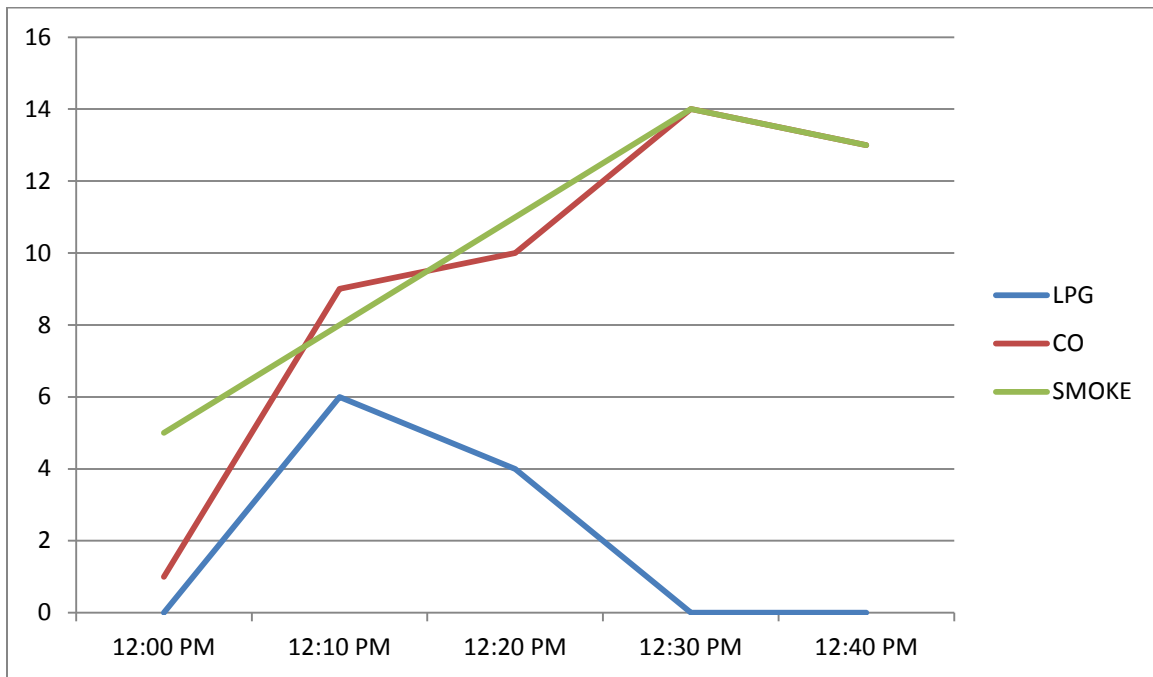

Figure 29 Air Quality data by UNEP's Air Quality Monitoring System

**c) Sensor data reading at Eastern car park**

Sensor data was taken from the Eastern car park at midday and the results is shown in figure 27 below:



*Figure 30 MQ-7 Sensor data readings at Eastern Car Park in UN complex*

The results show that there was a significant change in the CO levels as well as smoke levels. This can be attributed to the fact that this being the main car park area, there is a lot of activities in terms of vehicles coming and leaving. The CO levels are therefore high as there is more fumes from the exhaust of the cars.

The data was also compared to the readings from the UNEP'S air quality monitoring system. There was a very close resemblance and this can be shown in figure 28 below:



Figure 31 Air quality data from UNEP's Air quality monitoring system in the Eastern car park area

#### 4.8. Interpretation of the results

Table 1 below gives an explanation and guidelines of air quality as set by the Environment Protection Agency.

Air Quality Index (AQI) Values	Levels of Health Concern	Colors
<i>When the AQI is in this range:</i>	<i>...air quality conditions are:</i>	<i>...as symbolized by this color:</i>
0 to 50	Good	Green
51 to 100	Moderate	Yellow
101 to 150	Unhealthy for Sensitive Groups	Orange
151 to 200	Unhealthy	Red
201 to 300	Very Unhealthy	Purple
301 to 500	Hazardous	Maroon

Table 1: AQI Index

From the readings both done by the prototype developed in this research and those done by UNEP’s Air quality monitoring system, it is evident that the levels of carbon monoxide were consistent. The table above also shows that these levels are within the allowed limits i.e. “good” in terms of health concerns.

Even though the data from sensor readings of this prototype represents few minutes of readings, it can be concluded that the data is accurate as it closely matches the average readings that were taken by UNEP’s air quality monitoring system. This is as shown below:

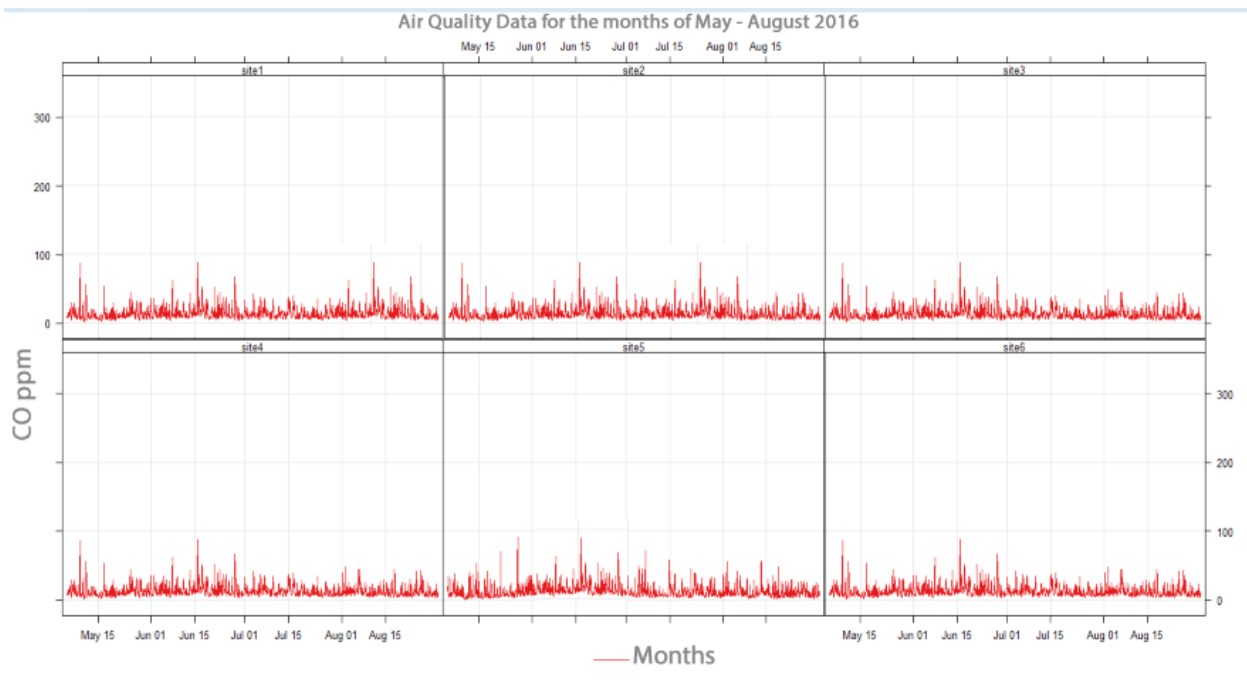

*Figure 32: Air quality data form the months of May – August (DEWA)*

The readings show that the level of CO on highest value is less than 100 ppm through all the months the data was taken. It can also be seen that on average, the readings is significantly low and ranges between 0 – 10 ppm.

## CHAPTER FIVE

### SUMMARY, CONCLUSIONS AND RECOMMENDATIONS

#### 5.1. Introduction

The chapter evaluates whether the objectives of the study have been met, assesses the value of the research, shows the limitations of the study and finally gives conclusions and recommendations.

#### 5.2. Evaluation of Research Objectives

**Objective one:** *To explore how Internet of Things has been used in developing various systems for environmental monitoring with a detailed study on air quality monitoring.*

The study began with explaining the meaning of IoT, then reviewed the enabling technologies and finally carried out an in depth study on architectures that have been used in environmental monitoring with an emphasis on air quality monitoring systems. These results are documented in the literature review section.

**Objective two:** *To study the various IoT enabling technologies and architectures used for environmental monitoring with an emphasis on air quality monitoring.*

The technologies were studied based on blocks i.e. the enabling technologies were grouped in bigger blocks than individual technologies studies in each relevant block. The architectures that have been used in developing IoT air quality monitoring systems were also studied and were used in developing the architectural framework for this study.

**Objective three:** *To study the current air quality monitoring systems in Kenya.*

An intensive study through face to face interviews, document analysis and questionnaires were used to meet this objective. The systems currently used for air quality monitoring in Kenya were therefore studied and documented under the findings in Chapter 4 of this research study.

**Objective four:** *To propose an IoT architecture for air quality monitoring and develop an air quality monitoring system prototype based on the proposed architecture.*



An architecture was developed based on IoT architectures that have previously been successfully implemented. The architecture implementation was tested by the use of a prototype and the results of air quality data has been documented in Chapter 4 of this research work.

### **5.3. Summary of Findings**

From the findings on the current air quality monitoring practices in Kenya it was evident that the methods were not satisfactory. This indicated that there was need for adoption of efficient air quality monitoring that is less costly but at the same time is able to monitor a large area and provide regular air quality information.

The study revealed that the various challenges faced by the environmental authorities in air quality monitoring were; poor coverage by weather stations, high cost of procuring, installation and maintenance of the monitoring systems, lack of technical knowledge required for installation, operation and maintenance of otherwise complex monitoring systems, insecurity of the instruments, ineffective information dissemination and non-user centered air quality information.

The also study also found out that IoT enabled air quality monitoring systems have already been developed and adopted in other developing countries and can therefore be developed in Kenya owing to the fact that Kenya has the facilities required.

In regards to the prototype design and implementation, the study found out that the air quality monitoring systems using the IoT can readily be implemented as the tools needed can be obtained at low cost and the enabling technologies are already in place in Kenya. The sensor nodes and the micro-controllers are readily available and are easily programmable. These systems can also be readily integrated into existing ICT facilities and therefore be able to use the facilities such as internet power and server storage.

It was also evident that the system is scalable and can therefore be scaled to cover large areas of the city to be able to obtain data from almost all parts of the city. The results from the sensor readings as compared to the systems developed showed that the prototype can give accurate results and therefore only needs few improvements in terms of procuring slightly more calibrated nodes that are equally not expensive compared to the current systems in use.

Finally, the study established that the possible solutions to improve current challenges of air quality monitoring by environmental authorities can be the adoption of the proposed and tested architectural framework for the air quality monitoring practices in Kenya.

#### **5.4. Conclusions**

In conclusion, the study established that the possible solutions to improve current challenges of air quality monitoring by environmental authorities can be done through the adoption of IoT system in the air quality monitoring practices in Kenya.

The air quality monitoring systems based on IoT will improve efficiency of air quality monitoring as the systems are scalable, low-cost, provide sensing accuracy, can be integrated to other ICT systems and can obtain air quality data with a wide coverage with minimal or no human interaction.

The air quality monitoring systems based on IoT will also make it possible to timely disseminate air quality data to all the citizens and the environmental authorities to appropriate actions.

#### **5.5. Limitation of the Study and Suggestions for Future Research**

In the process of conducting this study, it encountered a number of limitations some of which offer opportunities for future research.

The first limitation was identified during the prototype design in terms of the in-ability of the vendors to provide accurate information on the types of sensors they sell. It was evident that there are calibrated sensor nodes and the non-calibrated ones and the only difference is in terms of prices and when this is not put into consideration, the results can be very in-accurate. In this research, this was a major problem as it prolonged the duration of the research. The nodes that were initially purchased were the non-calibrated ones and acquiring the calibrated ones took time. For future research therefore, when one purchases the non-calibrated sensors, further action must be taken to calibrate them to be able to obtain accurate results.

The other limitation was in terms of the inability to obtain data from the respondents. Internet of things being a new concept, the respondents had very little knowledge on this area and therefore

provided little or no information. For future research, it will therefore be important to create awareness to the citizens on these technologies. This can be easily done as the large population is already using smart devices. Telecommunication companies can also readily disseminate the awareness of these technologies to their customers simply through the broadcast text messages by providing links on where information about IoT and its areas of application can be obtained.

Since the study is solely conducted in Nairobi County, the results may suffer from regional biases. Therefore the results need to be interpreted carefully and replicated in other Departments in other counties to improve their relevance.

The results of this study suggest new directions for future research. Researchers in the field of information system ought to put more emphasis on adoption and assimilation of Internet of Things as a technological innovation rather than administrative innovation.

## **5.6. Recommendations**

The study recommended that the possible solutions for environmental monitoring; creating labs for testing the technologies that make up the internet of things as this can be vital in building systems that can readily be used for air quality.

The environmental authorities should also create awareness on air quality as well as provide a proper channel for dissemination air quality information to the public. This will ensure proper planning as well as help in the implementations regarding control of air pollution.

## BIBLIOGRAPHY

- Al-Fuqaha, M. M. (2015). Internet of Things: A Survey on Enabling Technologies, Protocols, and Applications. *IEEE*, 2347-2375.
- Amitava, G., Rapeepat, R., Bishwarup, M., Nitin, M., & Tim, T. (2010). LTE-advanced: next-generation wireless broadband technology [Invited Paper]. *IEEE Wireless Communications* .
- Ángel, A., Álvaro, M., Rubén, B., & Roberto, C. (2014). Protocol and Architecture to Bring Things into Internet of Things. *International Journal of Distributed Sensor Networks*, 1-18.
- Bhole. (2015). A review of emerging technologies under Internet Of Things. *International Research Journal of Engineering and Technology (IRJET)*, 1612-1615.
- Charith, P., Arkady, Z., Peter, C., & Dimitrios, G. (2014). Context aware computing for the internet of things: A survey. *IEEE Communication Surveys and Tutorials*, 414-454.
- Deepali, V., & Satbir, J. (2013). SCALABLE, ROBUST AND REAL TIME COMMUNICATION ARCHITECTURE FOR WIRELESS SENSOR NETWORKS. *arxiv*, 1-6.
- Dharmendra, S., Vineet, T., Kumar, K., B, B., & S, A. (2015). Small and medium range wireless electronic notice board using Bluetooth and ZigBee. *India Conference (INDICON), 2015 Annual IEEE*.
- Dunkels, Gronvall, & Voigt. (2014). Contiki - a lightweight and flexible operating system for tiny networked sensors. *Local Computer Networks, 2004. 29th Annual IEEE International Conference on*, 455-462.
- Garth, C., & Farzam, V. (2014). Wireless sensor networks and LTE-A network convergence. *Local Computer Networks (LCN), 2013 IEEE 38th Conference on*.

- Ghobakhlou, A., Zandi, S., & Sallis, P. (2011). Development of environmental monitoring system with wireless sensor networks. *International Congress on Modelling and Simulation*.
- Graneheim, & Lundman. (2004). Qualitative content analysis in nursing research: concepts, procedures and measures to achieve trustworthiness. *academia.edu*.
- Jayavardhana, G., Rajkumar, B., Slaven, M., & Marimuthu, P. (2013). Internet of Things (IoT): A Vision, Architectural Elements, and Future Directions. *arXiv.org*, 1-19.
- Jiachen, Y., Jianxiong, Z., Z. L., & Houbing, S. (2015). A Real-Time Monitoring System of Industry Carbon Monoxide Based on Wireless Sensor Networks. *Multidisciplinary Digital Publishing Institute*.
- John, S., Takuki, K., Peintner, D., & Rumen, K. (2011). Efficient XML interchange (EXI) format 1.0. *W3C Proposed Recommendation 20*.
- Kim, E., Kaspar, E., Gomez, C., & Bormann, C. (2012). Problem Statement and Requirements for IPv6 over Low-Power Wireless Personal Area Network (6LoWPAN) Routing. *Internet Engineering Task Force (IETF)*, 1-32.
- Koshizuka, N., & Sakamura, K. (2010). Ubiquitous ID: standards for ubiquitous computing and the Internet of Things. *IEEE Pervasive Computing*, 98-101.
- Luigi, A., Antonio, I., & Giacomo, M. (2010). The Internet of Things: A survey. *elsevier*, 1-19.
- Luis, S., Luis, M., Jose, A., Galachea, Pablo, S., Juan, S., . . . Dennis, P. (2014). SmartSantander: IoT experimentation over a smart city testbed. *Science Direct*, 217–238.
- Matthew, G., & Simon, K. (2011). Internet of Things: Services and Applications Categorization. *Advances in Internet of Things*, 27-31.
- Maxwell, & Joseph. (2012). Qualitative research design: An interactive approach: An interactive approach. *Sage*.

- Miao, W., Ting-Jie, L., Fei-Yang, L., Jing, S., & Hui-Ying, D. (2010). Research on the architecture of Internet of Things. *Advanced Computer Theory and Engineering (ICACTE), 2010 3rd International Conference on.*
- Paolo, B., Giuseppe, C., Antonio, C., & Luca, F. (2013). Convergence of MANET and WSN in IoT Urban Scenarios. *IEEE SENSORS JOURNAL*, 3558-3567.
- Patrick, G., & Peter, F. (2009). Internet of things strategic research roadmap. *The Cluster of European Research Projects, Tech. Rep.*
- Payam, B., Wei, W., Cory, H., & Kerry, T. (2012). Semantics for the Internet of Things: Early Progress and Back to the Future. *International Journal on Semantic Web and Information Systems (IJSWIS) 8(1)*, 21.
- Peter, C., Tim, W., Raja, J., Wen, H., Philip, V., & Darren, M. (2010). Environmental Wireless Sensor Networks. *Proceedings of the IEEE*, 1903 - 1917.
- Rajalakshmi, A., Karthick, S., & Valarmathy, S. (2015). Vehicular Pollution and Status Monitoring Using RFID. *International Journal of Advanced Research in Science, Engineering and Technology.*
- Salvatore, G., Giuseppe, L.-R., Gloria, M., Daniele, P., & Salvator, V. (2014). Development of an IoT Environmental Monitoring Application with a Novel Middleware for Resource Constrained Devices. *Networking and Distributed Systems*, 1-6.
- Shifeng, F., Li, X., Yunqiang, Z., Jiaerheng, A., Jianwu, Y., & Jianwu, Y. (2014). An Integrated System for Regional Environmental Monitoring and Management Based on Internet of Things. *IEEE TRANSACTIONS ON INDUSTRIAL INFORMATICS*, 1596-1604.
- Srinivas, D., Parveen, S., Hongzhang, L., Ruilin, L., Liviu, I., & Badri, N. (2013). *ACM Digital library.*
- Srinivas, D., Parveen, S., Hongzhang, L., Ruilin, L., Liviu, I., & Badri, N. (2013). Real-time Air Quality Monitoring Through Mobile Sensing in Metropolitan Areas. *cs.rutgers.edu.*

Trochim, W. (2012).

Xing, X., Wang, J., & Li, M. (2010). Services and Key Technologies of the Internet of Things. *ZTE Communications*.

Zablon, S., Kennedy, T., Kennedy, O., Paul, N., John, N., Victo, O., . . . William, A. (2015). Ambient Air Quality Monitoring and Audit over Athi River Township, Kenya. *International Journal of Scientific Research in Environmental Sciences*.

Zainal, & Zaidah. (2007). Case study as a research method. *Jurnal Kemanusiaan*.

Zhang-Cheng, H., & Jia-Sheng, H. (2011). Ultrawideband filter technologies. *IEEE Microwave Magazine*, 56-68.

Zhihong, Y., Yingzhao, Y., Yu, Y., Yufeng, P., Xiaobo, W., & Wenji, L. (2011). Study and application on the architecture and key technologies for IOT. *Multimedia Technology (ICMT), 2011 International Conference on*.