



THE UNIVERSITY OF NAIROBI

**COLLEGE OF BIOLOGICAL AND PHYSICAL SCIENCES
SCHOOL OF COMPUTING AND INFORMATICS**

AUTO -TELEMATICS

**AN AUTO TELEMATICS SYSTEM FOR INSURANCE PREMIUM RATING &
PRICING**

IRODE PHILIP LUVUGA

**A RESEARCH PROJECT SUBMITTED TO THE SCHOOL OF COMPUTING AND
INFORMATICS IN PARTIAL FULFILLMENT OF THE REQUIREMENTS FOR THE
AWARD OF A MASTER OF SCIENCE DEGREE IN DISTRIBUTED COMPUTING
TECHNOLOGY OF UNIVERSITY OF NAIROBI**

NOVEMBER 2017

DECLARATION.

CANDIDATE.

I declare that this project is my original work and to the best of my knowledge, this work has not been submitted for any other award in any University.

Signature: _____

Date _____

Irode Philip Luvuga.

P53/72993/2014.

PROJECT SUPERVISOR.

This Project report has been submitted in partial fulfillment for the requirement for the award of a Master's Degree in Distributed Computing Technology at the University of Nairobi with my approval as the University Supervisor.

Signature: _____

Date _____

Dr. Elisha O Abade.
School of Computing and Informatics.
University of Nairobi.

DEDICATION.

This project is dedicated to my parents Mr. and Mrs. Luvuga, my immediate family; my wife Carol, sons Ansel and Ayden and not forgetting my beloved siblings.

Your faith in me, the push and unending love made this possible.

God bless all of you.

ACKNOWLEDGEMENT

I would first of all like to give thanks to the Almighty God for the gift of life, good health and seeing me through this and for providing the resources that have enabled me complete my studies in this programme. This study was made possible due to the dedication of my supervisor, support from my family, and encouragement from my friends. I would like to extend my heartfelt gratitude to my project guide and Supervisor Dr. Elisha Abade, the supervisory panel and the University of Nairobi; Dr. Kahonge Prof. Waema and the College of Physical & Biological Sciences for their trust in my work and regular guidance throughout this research project. I would like to acknowledge the significant impact and support in their continuous guidance and outstanding supervision, counsel, advice, support, patience and for continuously being available during the entire research period.

My sincere gratitude also goes to my immediate family, my wife Carol, and my two sons Ansel and Ayden and to my parents.

May the Almighty God bless all of you immensely.

ABSTRACT.

Insurance telematics is a new technology that has been poised to transform and change the way we buy and underwrite insurance by 2020. Insurance Premium is a major variable that determines if a client will buy or take up a policy cover or not. With the current stiff competition being felt in the Industry, the local insurance industry continues to suffer big losses due to unhealthy business practice of competitor undercutting among the insurers to attract more clients but exposing the underwriting companies to potential high risks. This in most cases means that the product is totally underpriced to the extent that it would be uneconomical and unsustainable in the long run for the insurance firms.

This research outlines a technology defined model that should be used to determine the ideal premium rate payable in the Motor Insurance industry in Nairobi county taking into account all the variables and the risk exposure of the policy holder. Insurable risk for a motor vehicle cannot be classified as a standard rate percentage item applicable uniformly without considering the distribution of risk in various geo-location regions and the drivers attributes.

The developed Systems prototype Model defines a scientifically insurable risk that gives the ideal premium cost comprising of the various real time risk factors taking into account all the variables, unlike the conventional model of underwriting which merely classifies all motor vehicle owners to a broad spectrum based on a written application form and previous records which might not be true. This solution seeks to price or adjust the payable insurance premium on the actual risk. The system model is able to determine the insurable risk based on the drivers attributes, and profile, location of the vehicle in relation to risk geo-locations map, monitoring the driving parameters of the vehicle by the driver, and the driving style. This enable the insurance company determines costs associated with the risk cover based on factual facts which are scientifically determined by the real risks.

This model provides accurate and reliable underwriting benchmark to be used to determine the insurable risk. The vehicles operations are monitored from the way it's being driven, location, and the drivers attributes.

Key Words— Auto Insurance Rating Model, Dynamic Traction Control, Global System for Mobile Communication, Pay-As-You- Drive (PAYD), Pay –How- You Drive (PHYD), Telematics

TABLE OF CONTENTS

Dedication	i
Acknowledgement	ii
Abstract	iv
Table of Contents.....	v
List Figures	viii
List Of Tables	ix
Acronyms	x
Definition Of Terms	xi
CHAPTER 1:	1
INTRODUCTION	1
1.0 Introduction	1
1.2. Problem Statement.	3
1.3. Research Objective.....	4
1.4. Research Questions.	4
1.5. Justification & Rationale of the Study.....	4
1.6. Scope and Limitations of this Research and Study.	5
1.7. Organization of the Report.	6
CHAPTER 2	7
REVIEW OF RELATED LITERATURE.	7
2.0 Introduction	7
2.1 An Understanding of Telematics.	7
2.2. Telematics Overview.....	8
2.3. Application and Adoption of Telematics.....	8
2.3.1 Telematics Road Motoring, Safety and Security.	9
2.3.2 Telematics in Informational Assisted Navigation.....	9
2.3.3 Telematics Customized Entertainment & Infotainment.	9
2.3.4 Telematics in Device Diagnostics.....	10
2.3.4.0 Automotive Telematics' System Design Architecture.....	10
2.3.4.1 The Main Components of a Telematics System.....	10
2.3.4.2 The Telematics Control Unit (TCU).....	10
2.3.4.3 Telematics Network Operating System.	11
2. 4 Telematics Insurance in Kenya.	12
2.5 How does Telematics Usage-Based Insurance Work.....	14
2.6 Literature Review.....	14
2.6.0 Related Work.....	15

2.6.1	Early Related Research Work - Early 1900.....	15
2.6.2	Related Work and Contributions After 2000	16
2.7	Types of USAGE Based Insurance.....	22
2.7.1	Pay-at-the-Pump (PATP).....	22
2.7.2	Pay-as-You-Drive (PAYD).....	22
2.7.3	Pay-How-You Drive (PHYD).....	22
2.8	Research Gaps in Insurance Telematics.....	22
2.8.1	Standardization of Vehicle Manufacturers' of Telematics Dongle.....	23
2.8.2	Lack of Industry regulatory for Data security violation & Laws.....	23
2.8.3	Technology Cost.....	24
2.8.4	Government Policies & Regulatory Regime.....	24
2.9.	Conceptual Framework.....	25
CHAPTER 3		26
RESEARCH METHODOLOGY.....		26
3.0	Research Design.....	26
3.1	Sample Size and Field Justification.....	26
3.2	Data Source & Tools.....	27
3.3	Sample Data Input, Manipulation, Verification and Validation	28
3.4	Prototype Development Design.....	28
3.5	Planning.....	29
3.5.1	Conceptualization.....	30
3.5.2	Functional Analysis.....	30
3.5.3	Design.....	30
3.5.4	Implementation.....	31
3.6	Why this Methodology.....	32
3.7	Functional DFD of the Implemented Logic.....	32
3.8.	Requirements Budget.....	33
3.9.	Project Schedule.....	33
CHAPTER 4		34
RESULTS, FINDINGS AND DISCUSSION.....		34
4.0.	Results – Preamble.....	34
4.1.	Nairobi County	35
4.2.	Administrative Boundaries and Infrastructure.....	36
4.3	Police Post & Motor-Vehicle Related Data.....	37
4.4.	Road Classification & Set-up.....	38
4.5.1	Relationship of the Mileage & and Risk Vector.....	40
4.5.2	Relationship of the Weekly Time of Day Travel & Risk Vector.....	40

4.5.3	Sample Geo-Location Clustering for Risk Vector Index and Profile	40
4.6	Insurance Industry Matrices and Factors.....	42
4.7	Feedback and Response Overview.....	43
4.7.1	Research Respondents.	43
4.7.2	Maturity of the Insurance Companies studied in relation to the Motor vehicle Industry.	43
4.7.3	Company offers Telematics based Insurance.....	44
4.8	Simulation Implementation.	48
4.9	Programming Language Choice.	49
4.10	Simulation Capabilities.	49
4.11	Matrix Functionality Testing.	49
4.12	Models Results & Objective Discussion.	51
CHAPTER 5	54
CONCLUSIONS AND RECOMMENDATIONS.	54
5.0	Introduction.	54
5.1	Summary.	54
5.2	Research Study Recommendations.	55
References.	56
Appendix 1	58
Appendix 2	61
Appendix 4	69
Appendix 5	70

TABLE OF FIGURES

Figure 1:	Illustration of Essential components of Telematics.....	8
Figure 2	.Automotive Telematics' System Design Architecture.	10
Figure 3.	The Main Components of a Telematics System.....	11
Figure 5.	Telematics Functional Overview integrated to the Insurance Back-end.....	12
Figure 6:	Conceptual Framework of the research.....	25
Figure 7:	A Map illustration of Nairobi County, the area of study.....	27
Figure 8:	The following phases will be for part of the development design methodology.	29
Figure 9:	Functional Analysis.....	30
Figure 10:	Implementation Design overview.	31
Figure 11:	Functional DFD of the Implemented Logic.....	32
Figure 12:	Administrative Boundaries of Nairobi County.....	35
Figure 13:	Population Dispersion of Nairobi County.....	36
Figure 14:	Police Stations & Roads Network in Nairobi County.....	39
Figure 15:	Relative Mileage & Township Distance.....	41
Figure 16:	Nairobi County's Insurance Premium.	42
Figure 17:	Motor-Insurance Maturity in Industry.....	43
Figure 18:	Motor-Insurance Model offered to Market.....	44
Figure 19:	Period Insurance Co. has been using telematics.....	45
Figure 20:	Premium Rate Analysis.....	47
Figure 21:	Sample Prototype Screen-Capture	50

LIST OF TABLES.

Table 1.	Summary of Project Budget.....	37
Table 2.	Project Dataset Table.....	38
Table 3	Table of County Administrative townships.....	40
Table 4.	Table of related Motor vehicle Table.....	41
Table 5.	Project Schedule Table.....	38
Table 6.	Table of relative Distance (in kms) form Nairobi CBD.....	38
Table 7.	Table of relationship between Risk & Mileage.....	38
Table 8.	Table of relationship between Risk & Time of Day Travel.....	38
Table 9.	Table of sample Go-location Clustering.....	38
Table 10.	Table of Research Respondents.....	38

ACRONYMS.

- PII – Personal Identifiable Information.
- SSL – Secure Socket Layer.
- GIS – Geographic Information System
- GPS – Geographic Position System.
- AKI – Association of Kenya Insurers.
- DTC – Dynamic Traction Control.
- TCU – Telematics Control Unit.
- ECU – Electronics Control Unit.
- CRM – Customer Relationship Management
- TNO – Telematics Network Operating
- PAYD – Pay As You Drive
- PHYD - Pay How You Drive
- CAN –Controller Area Network
- TPMS - Tire Pressure Monitoring Systems.
- IDS/IPS – Intrusion Detection System/ Intrusion Prevention System.
- IDPS – Intrusion Detection & Prevention System.
- OEM – Original Equipment Manufacturer.
- MITM - Main in the Middle
- OBD-II – On –Board Diagnostics II
- GSM – Global System for Mobile communication
- IP – Internet Protocol
- NAT – Network Address Translation.
- SSO – Single Sign on
- OTA – Over the Air

DEFINATION OF TERMS.

- Business Intelligence** - Business Intelligence is a technology driven processes of analyzing data and presenting actionable information to help business leaders and management decision makers to make informed decisions from the processed data.
- Infotainment-** This is a term mostly associated with content served in such as in-car entertainment systems as it's meant to be informative as well as entertaining in order to attract the end users attention.
- Insurance premium** – This refers to the amount of money that an individual pays an insurance company or insurance provider in order to be given cover against a risk.
- Actuarial -** This is a term related to actuary which is a mathematical statistical calculation especially in relation to life insurance.
- Personal Identifiable Information (PII)** - This in the sphere of security is any data that could potentially identify a specific individual by distinguishing him/her.
- GPS Transceiver-** This is a technology device used in GPS (Geographical Positioning systems) to pinpoint the exact locations to the nearest appropriate location.
- Accelerometers -** This refers to a device used in measuring motion acceleration force.
- Gyrometers Sensors** - This are technology devices used in motoring or any other installation to help n determining angular velocity orientation. This means the orientation of the device. In motoring they are used to determine cornering and directional orientation.
- Ubber -** A location based application that offers a platform for hiring taxis. It's primarily a taxi app.
- M-Pesa -** A mobile based application used for money transfer and related payment platform operated by a mobile phone service provider locally in Kenya.
- Cloud Computing -** A technology based service and practice of utilizing remotely hosted (Over the Internet)resources of servers, compute infrastructure to store, manager or even provide services to clients rather than having locally on premise servers.
- Tachograph -** This a device that is normally fitted in vehicles to automatically record the vehicles speeds and mileage together with various activities of the driver.

CHAPTER 1:

INTRODUCTION

1.0 Introduction

Vehicle Telematics is defined as the aspect of distribution, receipt and storing data and information on vehicles using information communication technology (ICT), (Elsevier; 2015). It is based on the capture of sensor, geo-location and personal data, storage and exchange of these data in order to provide intelligent decisions and remote services to motor vehicle users. This technology has transformed what used to be purely mechanical vehicles into electronically controlled transportation and mobile devices. Motor vehicle details are now transmitted over infrastructure networks to external third parties and to other third party value-added service providers. This data is then analyzed using powerful *business intelligence* tools to provide feedback information on various services depending on the industry i.e. in Insurance companies for risk assessment, *Infotainment* companies for content uploading, traffic and law enforcement for controls on traffic, weather details for metrological institutions and predictions etc.

Telematics data usage has been adopted in various forms in our everyday life. Telematics has been introduced in the insurance industry for underwriting decisions, risk vectors and exposure evaluation. We have also seen it been adopted in remote diagnostics, roadside accident and mechanical assistance, telemedicine, emergency response evacuation and even stolen vehicle retrieval in track and trace services. In Kenya, there is an emerging sense of discontent in the way *insurance premium* is calculated based on the *actuarial* mathematics. The current procedure is that the premium is based on a fixed percentile rate determined by the regulatory body (Insurance Regulatory Authority) IRA for a certain period of time (www.ira.go.ke; assessed on 26th May 2017). These rates apply across board in the whole country without any due consideration of other risk factors like geo-location, personal attributes, motoring experience, lifestyle of the insured and other variables, e.g. type of weather, road type, professional life of insured, residential area etc. Various researchers and thought leaders have argued that the current methods of determining risk are not optimal at all. This is so since it is based on very limited immeasurable variables e.g. years of experience in active driving, any related road or accident history, driver's age, the type of car/vehicle being driven (Athearm et al 1989, Litman, 2008).

The risk attributed to driving on Nairobi County's roads cannot be an outcome of an actuarial mathematical function. There is a need for a research to be conducted into the premium rating proposed by the regulatory body to support and substantiate the rating. There are inherent variables that are grossly overlooked based on the individuals involved in the driving and the locations they drive which should be considered in the final decision of coming up with the risk rating.

There is a large spread of risk that primarily depends on such variables. These would include;

- Location – Nairobi’s crime risk rating should be considered.
- Speed – The driving habit of the driver.
- Braking/ Cornering – Variables associated with the drivers’ habit.
- Distance – Distance covered by the insurer over a certain period.

It has been proved that some locations are more prone to road accidents, theft and car burglary (National Police service, Kenya Security Index Report 2015) than others. The same case has also been identified to specific Kenyan highways where it has been determined that some major roads are prone to fatal accidents and major losses compared to others (National Transport & Safety Authority, Final 2015 Road Safety Status Report 2015). It can also be noted that some cars are not always on the road in comparison to others, i.e. a professional executive who drives his car to the office and parks there for a whole day until 5.00pm when he leaves is totally different from a marketing executive who has to drive his car in various office locations meeting his clients and exposing himself to road related risks. Thus the risk exposures of the various scenarios depicted above are quite different. The individuals have a different exposure to the risk through driving. In an I-Lab Research Paper done in 2013 by J.Paefgen (Paefgen J, University of Allen; 2013), the authors states that indeed the inconsistency of Information between the insured and insurer is greatly addressed by Telematics. It is therefore quite apparent that a problem does exist in determining and satisfactorily providing both the Insurers’ and the clients’ with a scientific method of determining an ideal risk premium that is agreeable to both parties and which will address the challenges facing the Industry. The current fixed rate pricing of auto insurance is therefore inefficient and actuarially inaccurate since motorists in different risk classes are subjected to pay the same amount of premium rates regardless of the number of times or frequency they are on the road, their driving behavior, geo-location and how often they are on the road (Litman 2008). This coupled with the myriad of challenges in fraud, unethical competition and numerous claims require immediate attention. Thus, this research proposes a risk rating model and prototype system based on Telematics that takes into consideration causal data that is not factored into in the common conventional risk rating model as proposed and enforced by the regulatory body Insurance Regulatory Authority (IRA). These are;

- Geo-location.(Based on the security clustering of Nairobi County)
- Distance Driven in a given period (Mileage) for the insured car or motor vehicle.
- Time of day when driving.(Day or Night)

Indeed there are other variables but for the purpose of this research, we will dwell on the variables outlined above. We will provide a model prototype to demonstrate this. It is expected that the value of real driving behavior data from the Motor vehicle data, geo-location mobility data provides a more accurate model of reflecting true risk exposure for determining the premium rate to the customers that is proportionate to the risk and offers a business/ economic sense to the underwriter.

1.2. Problem Statement.

The Motor Insurance Industry in Kenya is one of the most strenuous areas to operate in. This challenging environment has seen over six insurance companies either become insolvent, enter into receivership or taken to court for legal redress (Daily Nation Newspaper, September 22, 2012). Key issues facing this industry are;

- i. Stiff competition resulting from unhealthy and unsustainable business practices.
- ii. Fraudulent claims.
- iii. High Premium charges.
- iv. Weak legislation.
- v. Slow insurance uptake and
- vi. Limited innovation in technology for client /customer aligned product development.

It is important to note that most of these problems can be significantly tackled by addressing a single pain point; Technology. Technology has been identified to bridge barriers and as a great competitive advantage (Porter, M.E; 1985) Stiff competition which has resulted to price undercutting and unhealthy non-sustainable prices can be exhaustively addressed by adopting and developing products that align to the users' needs using technology. This will ensure they are priced correctly; therefore addressing the high premiums challenges. This will also address the fraudulent claims since if the technology is adopted as proposed in this research; it includes an embedded dongle that will provide relevant information to validate any fraud related issues especially on theft of motor vehicle and real causes of accidents and the respective locations. There will also be enhanced compliance to regulator legislation since the technology adopted will enhance the regulators minimum requirements and industry standard as they will be embedded to the products e.g. speed limits on designated roads.

It is therefore quite apparent that a problem does exist in determining and satisfactorily providing both the insurers' and the clients' with a scientific method of determining an ideal risk premium that is agreeable to both parties and that will address the challenges facing the Industry. The current fixed rate pricing of auto insurance is inefficient and actuarially inaccurate since motorists in different risk classes are subjected to pay the same amount of premium rates regardless of the number of times or frequency they are on the road, their driving behavior, geo-location and how often they are on the road. (S.Hushjank et al; 2014). This coupled with the myriad of challenges in fraud, unethical competition and numerous claims require immediate attention.

This research project therefore proposes a Telematics system to be used in insurance risk & premium pricing in motor insurance based on real time data mining from the automobiles. It is expected that the value of real driving behavioral data from the Motor vehicle, geo-location mobility data provides a more accurate model of reflecting true risk exposure for determining the premium rate to the customers that is proportionate to the risk and offers a business/ economic sense to the underwriter.

1.3. Research Objective.

The objectives of this research is to create an insurance pricing system prototype that uses real time data derived from the functionality and mobility of the motor vehicle, its location and assign respective risk indices that accurately map the related risk to the insured for premium calculation and subsequent payment.

In Summary this is as outlined below.

1. Confirm and establish that the adoption of Telematics as an insurance pricing model can significantly reduce/impact the cost of premium in motor vehicle underwriting.
2. Confirm and establish that adoption of Telematics as an insurance pricing model can significantly reduce/ and avert the huge losses faced by insurance underwriters and fraud in the insurance Industry.
3. To analyze the output of the prototype and give findings and recommendations of implementation of such a real world system.

1.4. Research Questions.

The successful outcome of this research will be conducted in alignment to the following questions which will form the foundation of the data collection and analysis processes;

1. What Data is required in building a comprehensive Telematics Model in comparison to the data collected in a conventional motor insurance?
2. Can the implementation/adoption of Telematics model & GIS data clearly express the risk vectors of an auto/motor insurance policy?
3. By what percentage decrease/or Increase is the rate derived from Telematics different from the conventional rate?

1.5. Justification & Rationale of the Study.

The increasingly competitive business environment in the Insurance Industry has resulted in pressure to develop and utilize alternative delivery channels and new products (Pearson & Robinson, 2007). The survival and success of an organization occurs when the organization creates and maintains a match between its strategy and the environment it operates in and also a relationship of its internal capacity and its strategy (Grant, 2002). The integration of Telematics and GIS in Motor Premium Insurance rate calculation will dramatically shift and disrupt the Kenyan Insurance Industry. The Current market which boasts of 43 licensed Insurers (as of June 2017) compete for a limited market that is synonymous with low insurance uptake, poor attitude towards insurance and perceived credibility issues with regard to settlement of claims. There is limited product innovation which has less regard to the shifting clientele market and lifestyle dynamics and population. There is also an outcry on the premium rates which is as a

result of the industry's blind eye to research and to carry out market reviews to understand the dynamics and needs of the targeted markets.

Motor Industry insurance requires innovation of insurance products to counter competition (EY Report, Insurance Industry 2011). There is also need to adopt technology in order to reign in on fraudulent claims and losses being experienced by the underwriter's. Fraudulent and dishonest claims are a major contributor to the winding up of at least (6) six insurance companies in Kenya. This is not only an industry hazard but a risk to the Kenyan Economy. The other related issue is pricing. Pricing in Insurance premium calculation; is a meticulous task (EY Insurance Industry – Challenges, reforms and Realignment- 2011). Price needs to be determined with a focus on long term sustainability. In reference to the stiff competition and price undercutting practice, it has been linked to the winding up of some of the insurance companies in the country. Experts in the Industry's state that price as long term sustainability, is only achievable when 'price' is tagged to "return to equity".

This research will also inform the industry players and stakeholders that product innovation and adoption of technology based on real time risk vectors and calculation provides for a scientific basis of economically pricing premiums in motor insurance. Related cost of money has been fairly priced (premium) based on real self-risk and therefore allaying the negative perception on insurance, promoting improved driving safety and enhancing the customers claim experience. On the other hand, to the underwriting company, it ensures there is sustainable pricing of the risk (no undercutting) and the long-term sustainability of the business is ensured , reduces claim costs and minimizes operational losses ; enhanced customer uptake and acquisition, improved loyalty and retention and brand.

1.6. Scope and Limitations of this Research and Study.

This project will be limited to the review of insurance motor private underwriting data in a major insurance market leader in Nairobi County. The Telematics data and information related to the research will also be limited to Nairobi City County as a geo-location variable. We will also only base our variable in this research on Mileage, Geo-location and time of day. Electronic Odometer (cornering and jerks) data and acceleration and driving habits will not be covered. Some aspect of data sensitivity will have to be addressed considering that the details contained relate to *Personal Identifiable Information* which is protected. We will also rely to a great deal on the information available in the public domain on areas to do with risk rating based on the National Transport and Safety Authority (NTSA) & Crime watch authorities report from the National Police Service Commission. However, some data will be collected from the relevant authorities (police service) on accidents, traffic offences in relation to road mapping.

1.7. Organization of the Report.

The organization of this report is in five Chapters. Chapter One covers the background information, Problem Statement, Objectives of the research, Rationale of the study, Scope, Limitations of the study and the General Organization of the Report.

Chapter two covers literature review comprising of the Telematics technology overview and related works done, case studies and other researchers' contributions to the field. We have an overview of the area of study captured in Chapter Three under Framework and Methodology applied to enable conclusive research results.

In Chapter four we discuss the research findings and related opinions. In chapter five, we cover conclusion and recommendations' form the study.

CHAPTER 2

REVIEW OF RELATED LITERATURE.

2.0 Introduction

This chapter presents the literature review on Telematics technology, its usage in insurance referred to as usage based insurance (UBI), its earlier adoption and some of the industry progress made and the related challenges in its areas of adoption. We review and articulate its impact and benefits to the Industry, related concerns to its application and the adoption which is the main focus of this research.

2.1 An Understanding of Telematics.

According to Ptolomeus, Telematics refers to the integrated use of telecommunication and Information Technology, (ICT) in Motor vehicles” (Ptolomeus 2016). In reference to Searchnetworking.techtarget.com, Telematics refers to a combination of two words, “telecommunications” and “Informatics” to describe the integrated use of communications and information technology to transmit, store and receive information from telecommunication devices to remote objects over a network.(www.searcnetworking.tetarget.com/defination/telematic;) The term Telematics has in the long term been associated with Nora & Minc as a term they coined up in 1978.it is a term that is used a combination in motor vehicle related to the transfer of information, telecommunication and the data processing for instantaneous decision making. In today’s motoring world, telematics technology is now predominantly used to refer to information and communication technology within the road vehicles (Nijkamp et al 1996; Van der Laan et al 1997).

There are a number of applications of Telematics in our modern lifestyles. Telematics is being used in providing services such as real-time navigation assistance, road side assistance, lost vehicle recovery assistance and more recently, motor insurance. (Ptolemeus Consulting Group, 2012).With the recent advancement of embedded technologies, tracking systems, telecommunication and vehicular technologies; sending and receiving data and information from Motor vehicle has become a possibility (Handel P: Skog L Insurance Telematics, 2014). This Technology driven innovation is now making it possible for insurers to use the miniature motor vehicle devices to provide and develop market-rich personalized insurance products and rates based not only on regulatory defined rates but also utilizing demographic data and real actual customer related variable data.

2.2. Telematics Overview.

A Telematics system incorporates three main basic concepts and capabilities. These are;

- 1) Two-way communication capabilities on Wireless Networks.
- 2) Location aware/sensing technology (GIS/GPS) and
- 3) Computing Platform for System control, Data processing interface to automotive electronic systems.

Telematics being a primarily an automotive oriented technology; the key components are two way communication and location technology (GPS) transceiver. These are used in combination with computer hardware and related systems i.e. Accelerometers, Gyrometers & Sensors for data processing to create a fully functional Telematics system.

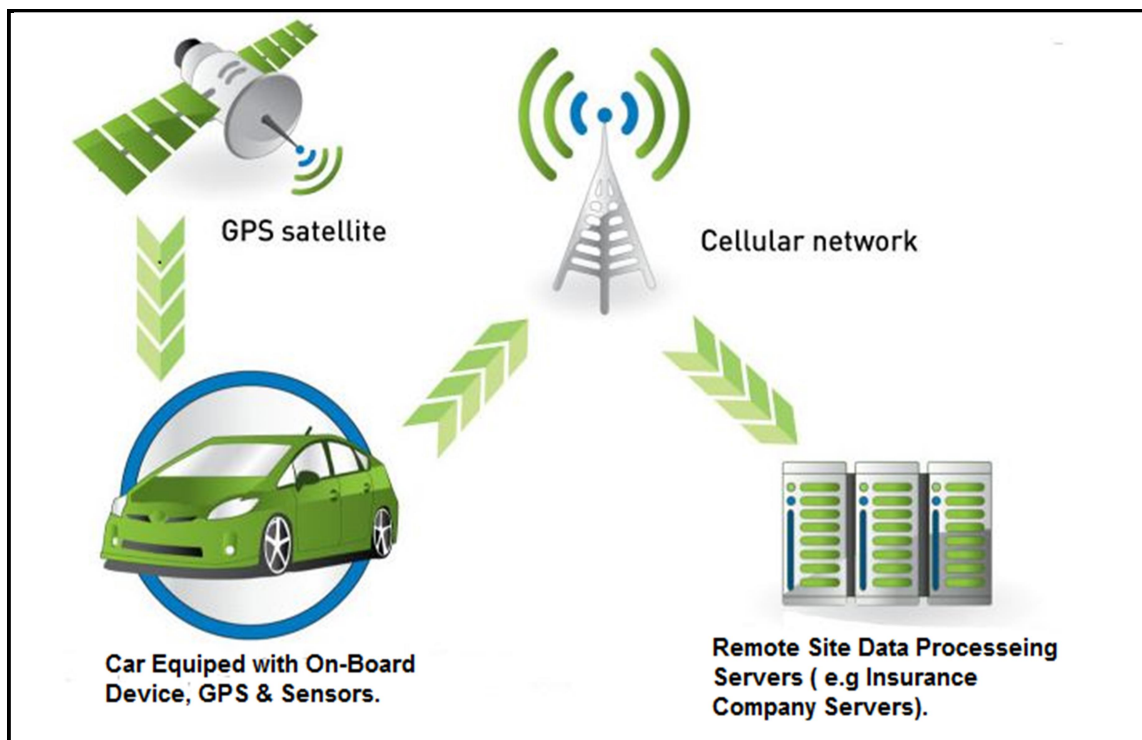

Figure 1: Illustration of Essential components of Telematics

(Source; <http://www.csio.com/assets/images/csio-telematics-english.jpg>)

2.3. Application and Adoption of Telematics.

All Organization are now been phased with the challenge of adopting technology in one way or the other in order to be competitive in the market. Change and innovation is often being mentioned as the very essence of our present day society. We have seen the adoption of digital technology in each industry in Kenya, Ubber for taxis in the transport sector, M-Pesa for digital money and banking, M-Kopa for credit and services, Ticket-Sasa for ticketing and so on. In the insurance industry in Kenya, we have started

seeing the adoption of Telematics as an alternative platform for risk rating and Premium calculation based on real time data from the insured and the active events and information generated from onboard computer dongles. Telematics usage is a potential game-changer for the insurance industry, especially for innovative auto-insurance in a market like Kenya where we have less than 5% penetration (Kenya Insurance Report. AKI, August 2016), and extremely high level of fraudulent related Insurance claims and payments. We have also seen various industries which are using Telematics services that can be broadly classified under;

- Road Motoring, Safety and Security.
- Informational Assisted Navigation.
- Customized Entertainment & Infotainment.
- Device Diagnostics.
- Medical Healthcare.

2.3.1 Telematics Road Motoring, Safety and Security.

Telematics has been widely adopted in the implementation and deployment of related motoring, safety and security services. These comprise of automatic accident and crash notification including emergency medical assistance and roadside rescue services. In security, Telematics has been adopted in tracking and recovery of stolen vehicles, Anti-theft alarm notification and remote door service unlocking and locking.

2.3.2 Telematics in Informational Assisted Navigation.

Telematics has also been adopted in the Information and Navigation industry and services. This has been used to provide access from Vehicles, Mobile devices to provide a variety geo-location based integrated services where a user can have access to his geo-location based specific information and content. Specific example in this category is a service like “turn –by turn navigation services”.

2.3.3 Telematics Customized Entertainment & Infotainment.

With the growth of internet bandwidth capacities, the industry has witnessed a steep growth in on-demand infotainment requests. This are direct on-demand requests by users for videos, music, Online radio, online live streaming content and even user are now able to customize and synchronize their contents with home entertainment system library. All these service are part of the applications that are being made possible by Telematics applications/adoption.

2.3.4 Telematics in Device Diagnostics.

Diagnosis is another area that has seen adoption of Telematics. Among the services in Diagnosis using Telematics are remote diagnosis, performance data collection and remote DTC scanning services. These include aspects like mileage covered since last location scan; time variance elapsed since last service update etc. This has been adopted mostly by tracking and haulage companies in monitoring their fleets.

2.3.4.0 Automotive Telematics' System Design Architecture.

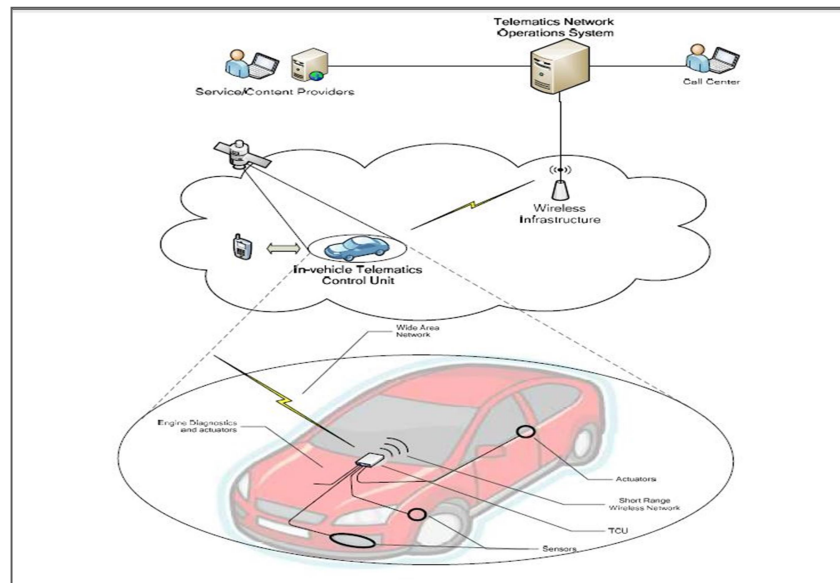

Figure 2 .Automotive Telematics' System Design Architecture.

Source: White Paper on Automotive Telematics – HSC.Com.

2.3.4.1 The Main Components of a Telematics System.

2.3.4.2 The Telematics Control Unit (TCU).

The Telematics Control Unit (TCU) is a device embedded in the vehicle's control unit that interacts with the vehicle engine control unit and the GPS satellite tracker and assesses and disseminates the telematics data and services collected from the car over the network.

The Telematics Control Unit consists of the following core functional blocks and interfaces.

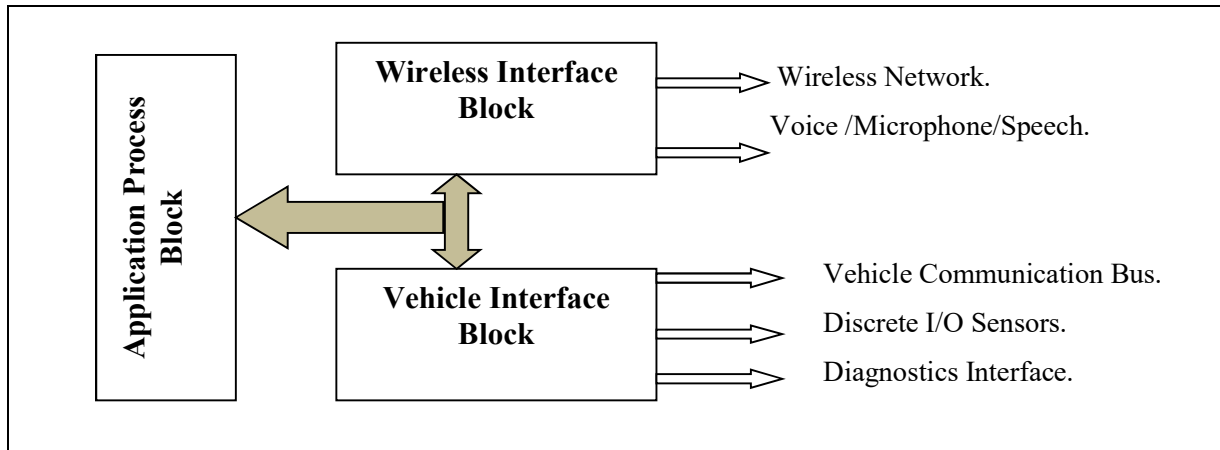

Figure 3. The Main Components of a Telematics System.

Source: Author.

- a. **Application Process Block** – This Module provides the framework for all related application level services provided by the Telematics Control Unit (TCU).
- b. **Wireless Interface Block** – It provides the transport mechanism for the communication between the Telematics Control Unit (TCU) and the Telematics Network.
- c. **Vehicle Interface Block** – This Module communicates with the rest of the Vehicle ECUs.

2.3.4.3 Telematics Network Operating System.

The Telematics Network Operating System represents the core from where all the related telematics services and information are delivered and all the raw data from the telematics control unit (TCU) is processed. The Telematics Network Operating System also acts as the fault management mediator, configuration status accounting and the security aspect control monitoring for the telematics systems.

Illustration of a Telematics Functional Overview integrated to the Insurance Back-end.

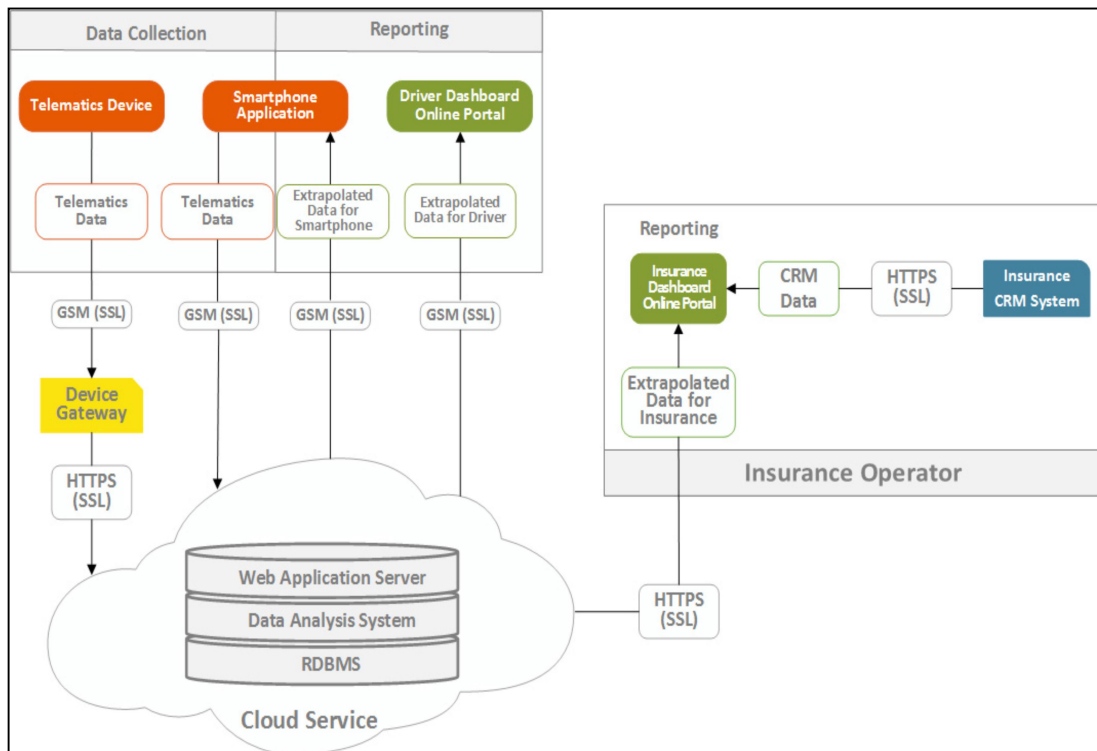

Figure 5. Illustration of a Telematics Functional Overview integrated to the Insurance Back-end.

Source: *White Paper on Automotive Telematics – HSC.Com.*

2.4 Telematics Insurance in Kenya.

Telematics systems have been adopted to provide the much needed real data in policy underwriting and risk rating in various parts of the world. For decades, insurance companies have struggled to provide clear actuarial data that is predictive of the related loss probability. In various related and quoted researches, the conventional method of classifying motor vehicle owners and drivers into pre-scribed risk rating based on various aspects e.g. driving experience, accident history, type of car, age, mode of car usage has been discredited for not being optimal (Litman, T, 2003) Telematics is bound to change all these by providing real causal data on the real-time variables related to the policy holder and the risk insured. This basically means that the more information an insurance company has on a certain individual risk the better these information is, the easier it will be to manage and determine the risk factor and diversification. As stated, the old method of policy and risk calculation is basically based on fixed variable that do not truly determine realistic risk factors and indicators. It has been established that an adoption of a Telematics based billing approach provides the following benefits to users and insurance policy buyers (Telematics Strategy for Automobile Insurers, I-Lab Whitepaper; May 2013).

- a) More precision in reflecting the actual risk exposure of the Insured and vehicle (Both to Insurance Company and owner).
- b) Improved in the uptake of the Insurance Products.
- c) Low Acquisition Cost related to customer onboarding.
- d) Reduced Operating Expenses.
- e) Reduced fraudulent claims.
- f) Recovery of Stolen Motor vehicle.
- g) Product Cost Pricing accuracy and adequacy.
- h) Improved Customer and Client Renewal & Retention.
- i) Improved Accident Factual Investigation.
- j) Increased in Safety and Security.
- k) Innovation on products offering.

Based on the challenges phasing the Kenyan insurance market, this provides for an avenue for addressing the continued discordant rise of premium rates, fraudulent claims and related vices in the Insurance Industry specifically for the motor insurance market. Litman, T. 2008, in his research work states that the use of the conventional method for premium calculation still leaves a large pool of risks that are not captured. These refers to attributes like the annual/ monthly mileage driven, the time of day/night and type of season the car is driven, type of route, geo-location of the area and even the neighborhood where the car is parked.

Telematics is yet to be fully adopted as an Insurance platform in Kenya as whole, let alone Nairobi. The most common and prevalent implementations of Telematics is currently in motor vehicle /car tracking and fleet monitoring and recovery. In a “Re-News” (The official Publication of the Kenya Re-insurance Corporation); Issue 6: February 2014)); the re-insurance industry body states that it expects a dynamic shift in trends to watch; from the conventional underwriting process to a more technology led set-up. The Author, James Njuguna states that tech enhancements could propel “Telematics to the level of an industry disruptor”.

In 2012, Gateway Insurance led the pack by unveiling a Telematics usage-based insurance which is billed and premium paid based on actual mileage travelled (Standard Media Newspaper , August 26th 2012,). We have had other organizations which have also joined in by unveiling their respective products offerings; these include, Britam General Insurance, APA and Jubilee. We also have leading Telematics service providers who have currently set-up operations locally. These include Mix Telematics of UK, Navisat Telematics, Telematics Africa, Digital Telematics, and Flex Telematics among others. However, their solutions are not meant for Insurance services but for fleet management and Car tacking services. This is a clear indication that there is great and immense potential in this technology.

2.5 How does Telematics Usage-Based Insurance Work.

The conventional method of determining the premium payable by a client is based on profiling the driver, the vehicle, related usage of the vehicle (Public or Private), cost of the car, model of vehicle (and some other adjustable variables which are basically subjective) which is in broad actuarial terms and of which a factor or a rate percentage (%) of premium is mapped. This has been disapproved and found to be unfair to a huge extent for some drivers. Basing the premiums on “How”, “Where”, “Duration” and “When” a driver drives, a concept known as Usage Based Insurance will allow companies to accurately calculate risk, target related discounts and market specific products to their respective clients. (Ferreira and Minikel, 2010) It has been noted that the use of improved causal and refined data leads to improved method of determining the cost of Insurance which reduces rating and pricing errors that are synonymous with a generalized conventional rating method (P. Desyllas, et al ;2013). With the improvements made in Technology, Wireless Sensors, *Cloud computing* and specific user tailored demands, Usage Based Insurance (UBI) has been used gradually (Dijksterhuis et al 2015). This comes from a research in the insurance and actuarial field that has estimated that individual’s driving risk is based on various demographic variables. For example the drivers’ experience, age, (Vlakveld 2005,) Gender (Lonczak et al 2007) and family status (Litman 2005) of a vehicle driver. Besides the demographic variables, Geographical aspect of the environment and security aspects of locations, time of day or night and roads’ conditions of the driving also do contribute significantly.

The recently adopted and suggested method to address the mentioned weaknesses related to the conventional method is by adopting Telematics technology. This involves collecting data on the vehicle’s movement, location and time of drive among other factors. This is done using an on-board GPS and OBD-II device. The collected data is processed, analyzed and subsequently communicated to the insurer who uses it to intelligently access the risk exposure and assign the appropriate premium cost using a back-end algorithm and an actuarial calculation.

2.6 Literature Review.

In Kenya, the current premium calculation and billing in motor vehicle insurance as earlier mentioned is not optimally tailored and reflective of the risk exposure of the end user. Very key and important variables and parameters such as mileage travelled in a certain period, types of roads being driven on, geo-location and weather conditions etc. are not considered for the premium risk rating and calculation, yet these are very key essential variable that greatly determine the potential of an accident or a claim for that matter. There is a very strong prove and evidence of direct correlation of annul mileage and claim/loss rates (Ferreira and Minikel, 2010) Litman 2011, Laurens et al (1999). Development of advanced IT Systems, significant drop in the technology cost of ownership as well as the necessity for market differentiation and high innovation culture has greatly facilitated the adoption of new billing and

risk rating in the motor insurance industry. We look at the stages taken and progress made in this field and related works done by earlier adopters of the telematics technology.

2.6.0 Related Work.

2.6.1 Early Related Research Work - Early 1900.

Determining a fair, market driven and accurate premium price for an insurance product especially for motor is a very important aspect for the industry from time immemorial. This applies to both the insured and the insurance company. Automobile event data recorders have been implemented or installed in vehicles since the 1960's and they are still part and parcel of the current advancement in the Telematics Insurance. The model of usage based or in other terms mileage based insurance was first discussed by Nobel Laureate William Vickrey in 1968. In his research and publicized work, he identified various flaws in the then rating mechanism associated with insurance underwriting. He urged that the premiums did not explicitly reveal the inference costs of accidents nor provide realistic pointers for adjusting trip and driving variables appropriately. As an alternative a proposal was put forth that championed a payment of insurance premiums tied to the purchase of gasoline fuel at pump stations. In his proposal, he rejects the regular mileage reading and reporting on the basis that the odometers were prone to fraud and interference from the respective car owners. However, this is debatable as the current state of Telematics devices fitted in modern cars are technology driven and have high inbuilt accuracy.

In response to the works of Vickrey, researchers at the University of California Berkley were the first to provide a scientific angle to Vickreys' work in their highly publicized working papers, position statements, and research reports presentations to the state of California in the United States. Their first publication articulating this was done in 1990 by EL-Gassier. In the following years, we had subsequent contributions by Topias (1993) and Sugarman (1993) which were basically fronting the same solution but different in level of maximum compensation for the insured as per the risk insured.

Follow-up research works done by Wenzel (1995), did provide a fair comprehensive comparison of all the proposals, which included nine different proposals. Additional research work was also done by Bernstein (1994) in Usage Based Insurance but more in the academic quantitative analysis way, in which he studied the different insurance offerings on the motorists. He used travel research data; insurance and government sponsored data in a simulating a prototype where he did identify those different age groups, income groups as either better off or worse off in a certain model of usage based insurance offerings. We also have seen the exceptional additional contributions by Khazoom (2000) whereby he proposes a hybrid approach to the usage based insurance as an alternative.

2.6.2 Related Work and Contributions After 2000

Todd Litman a researcher at the Victoria Transport Policy Institute in Canada was among the first individuals who proposed a GPS-Based technology as a means of ascertaining and calculating insurance premiums. Initial research works on this was basically based on the pay at the Pump model only; (Litman 1997, Litman 2008). Telematics Insurance started as a segment/ niche market when the technology was first introduced. It was initially inhibited by the high implementation cost related to the technology and devices. However, the advancement in technology and reduced set-up cost provided a launching pad from which some of this solution. Coroana (2006) provided a prototype named “*Tachograph*” which enabled the calculation of premiums based on the individual behavior. The solution collected data on the users, (both GPS and acceleration related) for personal billing of insurance premiums.

Lindberg et al (2005) provided additional input research and an overview in this filed in their field experiments on the distance based vehicle insurance using Telematics (GPS and motor vehicle data recorders). This was based on the very well documented “Borlange experiments” (a series of experiments done in Borlange area in Sweden, which sort to answer various Telematics questions).

Recent developments have also emerged basing premiums calculation on the use of Telematics but addressing key concerns of data Privacy and security which have become a hot issue hindering the growth of the Telematics model of insurance underwriting. A good case of this is the work done by Greaves & De Gruyter, 2002. Additional research has also been done by Iqbal & Lin 2006, 2007 which showed that it’s actually possible to profile individuals using the GPS locations.

Research work into Telematics based Insurance done by Fincham et al; 1995 titled “SAMOVAR” – (Safety Assessment Monitoring On –Vehicle with Automated Recording) showed that there was significant improvement in Pricing of Insurance based on improved driving habits and in a ripple effect the accidents prevalence/reduction. Wouters and Bos, 2000 presented similar report findings and support to the impact and effect of Telematics as a pricing tool. There are various solutions both academic and in industrial related researches and developments that have been implemented globally to provide insurance cover based on real casual data generated by the motor vehicles Telematics and generally referred to as Usage based Insurance. This trend is supported by various researches that have largely confirmed that telematics data is more consistent and dependable and of higher resolution and precision than traditional method of underwriting based on regulator rates and thus increasing the rationality, soundness and quality of insights inferred to by insurance underwriting firms. (Wolf et al, 2001, 2003; Blanchard et al 2010; Forrest and Pearson, 2005; Stopher et al 2007).

The collected data has led to insurance companies developing products specifically targeted to specific market niche and individuals. Particularly rich in information are three sources of Vehicle Sensor data: These are Geographical Satellite Positioning Data (GPS), Inertial measurements unit and the vehicles onboard Diagnostic Unit. These devices employ different technologies and may be used alone or in combinations to provide extremely personalized data that provides for precise risk premium billing platform. Instead of relying on the conventional mode of underwriting, Telematics makes it possible to account for the type of road, weather condition and time of the day when the insured was driving. (Weiss and Smollik, 2012)

In justifying why Telematics should be a basis of premium calculation and risk rating, (Ayuso et al 2014, 2016) are some of the researchers who have documented the relationship between the distance travelled in mileage and the occurrence of a claim related accident. This was done using Weibull regression models involving both policy and Telematics. Paefagan et al 2014) investigated the relationship between an accident and the drivers driving habits using logic regression models to also illustrate the same. It has also been noted that the adoption of Telematics as a basis of insurance rating fosters a self-selection amongst motorists which positively impacts on the insurers risk portfolio by attracting low-risk clients and drivers, while highly risky drivers and car owners either significantly improve their driving skills or move out altogether. In a nutshell, it's been theoretically proved that once users are offered usage based Telematics insurance, it has a three pointer effect on the insurance company; good risks enter the insurance company Bad risks transform to good risks and bad risks leave the company (Lindbergh et al 2011 and Arvidson, 2010).

In a similar research conducted by (Soleymanian et al 2016), they found out that the adoption of Telematics in insurance firms has three major benefits compared to the conventional uniform rate pricing. These are;

1. Consumers can choose the usage/consumption that best suits their needs. Both for low and high usage customers thus allowing for preference segmentation.
2. There is a potential for enhancing the welfare of the consumers as well.
3. Firm stand to gain a competitive advantage on Telematics usage.

Early implementations have been reported and adopted in the United States, (USA) Italy and United Kingdom (UK). However, the aspect of personal Identifiable Information (PII) Data being readily available for third party service providers has raised substantial privacy concerns among the perceived users and potential telematics market due to the ever increasing exposure of the users' data, habits and whereabouts including behaviors (Fano and Gershman, 2002, Thiesse, 2007; Iachello and Hong 2007, Hong et al 2008). In a related IT and IS research, it has been noted that privacy concerns are significant determinants of consumers' technology acceptance in any application or system implementation plan that involves the use and sharing of Personal

Identifiable Information (PII), (Angst and Agarwal 2009, Dinev and Hart, 2006; Sheng et al 2008). Therefore despite the articulated direct and quantifiable benefits that are direct derivative from Telematics adoption, the penetration of this service has remained stagnant or below expectations not only globally but even here in Kenya. It's low adoption and uptake has been attributed to the PII privacy concerns amongst possible clients and users (Filipova et al 2010) Other researchers have proposed a solution to this challenge by proposing privacy –enhancing designs of the Telematics (Coroama 2006, Duri et al, 2002, Iqbal and Lim 2010; Popa et al, 2009; Troncoso et al 2007). However, the same have been discredited for lacking the core principal of privacy and pricing as a basis of the Telematics premium pricing.

Below is a listed review of some of the solutions that have been put into production based on the Telematics technology in various countries globally and used for Insurance premiums' rating or usage based insurance.

No.	Product	Country	Concept & Product Status
1	Admiral Insurance "Pay How You Drive"	UK	<p>This is an insurance product providing 25% insurance discount upon sign-up and another 10% discount every month upon satisfactory "safe and eco-friendly driving".</p> <p>Technology Platform - GPS Based Telematics unit.</p> <p>Data Transmission – via GPRS.</p> <p>Product Status – In production and use in UK Councils.</p>
2	AIOI "Pay-as-You – Drive"	JAPAN	<p>This is a mileage based vehicle Telematics insurance product.</p> <p>Technology Platform – It's a Toyota's Telematics subscription service</p> <p>Data Transmission: Via GPRS technology.</p> <p>Product Status: Available on Toyota Lexus Vehicles.</p>
3	Amaguiz.com "pay-as-you-drive"	FRANCE	<p>This is a distance based vehicle Telematics insurance offering with additional value add services including automated emergency calls, vehicle recovery and driving statistics which comes as free add on services.</p> <p>Data Transmission: Via GPRS.</p> <p>Product Status – Available in France for interested drivers.</p>

4	American Family Insurance	USA	<p>An interactive recording device records the drivers driving habits such as breaking, cornering, and acceleration, collisions after and before. Both the driver and the road ahead are recorded which provides for the insurance company with data for analysis in case of an incident.</p> <p>Technology Platform: Audio/Video with GPRS Unit.</p> <p>Data Transmission: Via GPRS.</p> <p>Product: In Production and use in the USA.</p>
5	Aryeh Insurance	ISRAEL	<p>This is a distance based Telematics insurance solution product.</p> <p>Technology Platform: Telematics device retrieves mileage data and information from the on-vehicle electronics – (OBDI-II).</p> <p>Data Transmission – Wireless Transmission at specific Service Stations.</p> <p>Product Status: Available in Production.</p>
6.	AVIVA	CANADA	<p>The insures receive a premium discount upon policy renewal if they decide to send their driving data (Distance driven, night and Daytime driving hours, driving speeds) to the insurer, Data transmission is optional; clients can see the discounts they are eligible for prior to transmitting the data to the insurer, trip logs and driving statistics are available to the insured's local PC.</p> <p>Data Transmission – Device Connected to PC via USB, Data Sent to Insurer online.</p> <p>Product Status – Product available in production.</p>
7.	AXA	ITALY	<p>Distance Based Vehicle Insurance telematics.</p> <p>Technology Platform: GPS Based Telematics by Octo Telematics.</p> <p>Data Transmission : Via GRPS</p> <p>Product Status: Available in Production.</p>
8	AXA-Winterthur “Crash Recorder”	SWITZERL AND	<p>Event based data recorder fitted in the vehicle where drivers receive a 15% premium discount off the standard insurance premium.</p> <p>Technology Platform: event based data recorder.</p> <p>Data Transmission: Accelerometer information retrieved from the Data recorder in case of an accident.</p> <p>Product Status: Solution in Production.</p>
7	Cobra Wunelli	UK	<p>Distance Based vehicle insurance; stolen vehicle recovery comes as an add-on.</p> <p>Insurer has various providers to choose from including the following; Groupama Insurance, Equity Insurance, Co-operative Insurance, Allianz among others).</p>

			Data Transmission: GPRS.
			Technology Platform: “Cobra tracking device” using GPS Technology.
8.	Generali	ITALY	This is telematics-based motor-vehicle insurance; motorists and vehicle owners receive premium discounts upon policy sign up. It provides added value-ons like an emergency button for roadside assistance; automated emergency calls, stolen vehicle recovery and driving statistics come as free add-on service. Technology Platform: GPS based Telematics Unit. Data Transmission: Data transmission via GPRS. Product Status: Available in production.
9	GMAC Insurance	USA	This is a mileage based insurance service based on discount for mileage drivers (motorists that travel less than 15,000 miles per year). Technology Platform: OnStar Telematics platform available on all General Motors vehicles Data Transmission: GPRS. Product Status : Available to OnStar subscribers
10	Hollard “Pay-As-You-Drive”	SOUTH AFRICA	This is also a distance based vehicle insurance offering; Drivers subscribe to the insurance plans with varying monthly mileage allowance and pay commensurate premiums as per the distance, if allowed mileage is higher than actual travel, kilometers are accounted for in the following month; excess mileage at the end of the billing period is billed at an individual per mile rate. Stolen vehicle recovery is an add-on service. Technology Platform: GPS Based Tracker skytrax Telematics unit. Data Transmission: VIA GPRS Product Status: Available in production.
11	Liberty Mutual “Onboard Advisor”	USA	Fleet Management concept for commercial vehicles allowing Insurance firms to offer 15% discount in the first year and 40% on policy renewal. System assigns safety scores based on speeding, hard braking; cornering and fleet managers can track their vehicles and monitor them. Technology Platform: GPS based Telematics unit by General Electric’s including accelerator. Data Transmission: Via GPRS. Product Status: In Production.
12	MAPFRE	SPAIN	Telematics Insurance for drivers of age 18 to 30. Drivers receive a premium discount off the standard insurance premium; automated emergency calls, stolen vehicle recovery, and driving statistics come as

			<p>free add-on service. Depending on the mileage; driving performance, and accident involvement, motorists can receive an additional prepaid card for gasoline purchases as a bonus for good driving behavior of up to 60 Euro.</p> <p>Technology Platform: GPS Based Telematics Unit.</p> <p>Data Transmission: Via GPRS.</p> <p>Product Status – Available in production.</p>
13	Norwich Union	UK	<p>Distance based vehicle insurance for each driver, Road type, (Motorway, Dual Carriageway, Single lanes etc.) during pre-defined hours, high risk hours, etc.</p> <p>Technology Platform: Device connected to Vehicle diagnostic port, Mileage is derived from vehicle electronics and not GPS.</p> <p>Data Transmission: Via GPRS Unit in Device.</p> <p>Product Status: Cancelled.</p>
14	Progressive	USA	<p>Telematics based insurance that bases premiums discounts on Mileage driving hours, weekdays of driving and driving style (Excessive acceleration and hard Braking) clients receive premiums discounts upon policy renewal; trip logs, and driving statistics can be viewed online.</p> <p>Technology Platform: GPRS Unit in device</p> <p>Product Status: Available to drivers in selected USA states.</p>
15	Progressive “TripSense”	USA	<p>Distance based vehicle insurance; trip logs and driving statistics can be viewed online.</p> <p>Technology Platform: Device connected to Vehicle diagnostic port; mileage is derived from vehicle electronics not from GPS Signal.</p> <p>Data Transmission: Device connected to PC VIA USB data sent to insurer online.</p> <p>Product Status : Cancelled</p>
16	Royal & Sun Alliance Insurance	UK	<p>Telematics data is used to inform motorists of their driving behavior and make them aware of possibilities for more eco-friendly driving; Telematics data is not used for any insurance rate calculation, motorist can compare their driving and travel habits to those of other insurance clients.</p> <p>Technology Platform: Device connected to the vehicle Diagnostic port; information on driving and style related information is from Vehicle electronics and not the GPS signal.</p> <p>Data Transmission: Via GPRS.</p> <p>Product Status: Discontinued.</p>

Summarized Table of UBI solutions Implemented Worldwide.

2.7 Types of USAGE Based Insurance.

There are primarily three type of usage based insurance. These are;

2.7.1 Pay-at-the-Pump (PATP).

Pay at the Pump is an Insurance model whereby Insurance Companies were in liaison with oil companies of Petroleum stations and the insurance company would price the risk premium based on fuel consumption. This model however faced various challenges. First, the usage of Fuel as a basis of risk rating lacked merit as some key aspects of the individuals were not include. This included the drivers age, gender, vehicle type and age etc. Also notable were the challenges faced by the various fuel and Oils marketing companies. It therefore required that an insurance company get allegiance to very many oil marketers. This model is unattainable and impracticable to impalement and operates.

2.7.2 Pay-as-You-Drive (PAYD).

Pay –as-You – drive is usage model is directly linked to the emergence of Telematics. In this model, the Insurance Company uses the available technology of GPS and Motor vehicle OBD-II device to monitor the driving aspects of the motorist based on Mileage utilization. This gives a clear indication of the risk vectors that the insured is prone to and therefore giving the insurance company a near to real risk indicator.

2.7.3 Pay-How-You Drive (PHYD).

Pay how you drive is similar to pay as you drive. The insured pays premium based on data collected from the Telematics device in the vehicle. In pay as you drive the premium is based on the mileage clocked, while in PHYD, factors such as braking, cornering, acceleration and time of drive are considered. The insurance company then rates the insured based on a ‘score’.

2.8 Research Gaps in Insurance Telematics.

In as much as there is growing trend towards adoption and alignment to Technology driven insurance underwriting (Telematics), it can wholesomely be said that the growth of this field in this country has not been easy unlike in other countries with developed regulatory framework like South Africa and the rest of the leading developed western countries. There are areas and certain fundamental variables that have not been clearly defined and given due consideration to spur the required adoption of the technology. This is as articulated below.

2.8.1 Standardization of Vehicle Manufacturers' of Telematics Dongle.

Standardization is an industry best process that should be adopted for technology that has been tested and found to be functionally mature to provide consistent results and output and therefore enable the various users to adopt it as a benchmark for their implementations. For this technology to fully be deployed in each motor vehicle, and to allow the potential clients' who are the motorists, the freedom of buying insurance cover from any insurance telematics provider, a standard needs to be adopted for this technology. Maarit Moran & Trey Baker In their publication "Vehicle Telematics as a platform for Road Use Fess, November 2016, pg 24 -25 ; states that; Standardization enables interoperability, wherein different technologies can all operate within the established policy system and the system itself can accommodate different types of technologies. Interoperability also means that the devices will work in any state with any other vendor. They further state that where telematics has been deployed, automobile manufacturers, technology providers, in-vehicle service providers and the trucking companies have all expressed concerns regarding standardization. This has also been noted as an obstacle to a further research publication conducted by D. Karapiperis, A. Obersteadt et Al for a research done for the National Association of Insurance Commissioners & the Centre for Insurance Policy & Research, published in 2015 , titled ' Usage Based Insurance and Vehicle Telematics. This similarly applies locally where we have no a nationally accepted standard or any accepted standards that would form the basic benchmark for determining the accepted criterion of a dongle and the related technology that would be accepted for deploying the telematics device in the user's car. It therefore means that in the event an individual has to transfer from a certain insurance provider, then he has to get a new set-up of the pre-requisite technology that the new provider will be deploying. This is not only an additional cost, but a hustle that has greatly hindered the adoption of this technology.

2.8.2 Lack of Industry regulatory for Data security violation & Laws.

Industry Data Security Laws have also been an area that requires more effort in determining what direction should be adopted for telematics. As we speak now, the issue of Data security and privacy has been a major concern for the fully adoption of telematics. In a research publication, EY states that customers want to decide what data they can share and which one they can't; Fillipova et Al 2010. There have been various research works that have been done and proposals done to provide a middle ground and

tradeoffs between the Data owners and collectors of the same ; Coroanna , 2006; Duri et al 2002; Iqbal and Lin 2010. In their Thesis submission as well, Fano and Garshman, 2002. Fano and Gershman, 2002; Thiesse, 2007; Iachello and Hong, 2007; Hong et al., 2008). Information Systems (IS) research has shown that privacy concerns are an important determinant of consumers 'technology acceptance in applications that involve the use of privacy-sensitive data (Angst and Agarwal, 2009; Dinev and Hart, 2006; Sheng et al., 2008). In order to facilitate a widespread adoption of respective applications, it is crucial to balance the benefits of functional features of ubiquitous IS — which may increase perceived usefulness or ease of use — against their cost in terms of the privacy concerns they raise (Park, 2009; Zuo, 2010). This critical trade-off also holds for telematics insurance. In spite of alleged benefits, the market penetration of PAYD insurance tariffs has remained behind expectations with less than 1% of automobile insurance policies in Europe and North America. Its slow diffusion rate has been attributed to privacy concerns among potential customers (Filipova et al., 2010), which pose a major challenge to insurance IT professionals considering the introduction of information systems that enable telematics insurance

2.8.3 Technology Cost.

Telematics Insurance is a technology intensive undertaking that requires a total redesign of an Organizations' Infrastructure and Systems Set-up. (See Design Architecture in Chapter 2). The infrastructure required to set up this type of a business model requires organizations to heavily invest in Infrastructure technology, and security for the deployed systems a phenomena where the current organizations and business may find non-lucrative. There is therefore need for all key stakeholders and leading technology providers to consider proving alternative work arounds for deployable technology solutions that are not "cost intensive". In their research, Gerpott & Berg, 2011, provides a discussion which articulates the current challenge and gap provided by associated technology costs related to the deployment of Telematics technology for Insurance companies.

2.8.4 Government Policies & Regulatory Regime.

In Kenya currently, Insurance business is a regulated business area which is supervised by the Insurance Regulatory Authority (IRA). The insurance rates and the premium rates are decided by the Insurance regulatory board which sits and decides what rate should be the basis of all classes of business undertaking. This model has been found to be quite rigid and ancient in relation to embracing technology. The dynamics of business

nowadays requires quick decision making and agility which has been brought about by adopting technology. However, the modus operandi defined by the government policies makes it difficult for such flexible and adaptable business decisions to be made.

2.9. Conceptual Framework.

From the above literature review, it's clearly illustrated that the current method used in premium calculation is unfair to its respective clients. Not only is the client premium charged non-representative of their respective risk exposure, but also the underwriting firms are highly exposed based on some of the motoring variables that are not considered.

By adopting Telematics technology, where the various variables related to the driving habits, location and mileage of the users are monitored and analyzed, we will be able to appropriately deduce and provision different premiums to various users. This will reflect the different risk exposures indicated by the various variables, i.e. driving mileages in a certain period, night/day driving, geolocation of driver in related risk profile of the area etc.

The proposed conceptual framework for the research is as illustrated below.

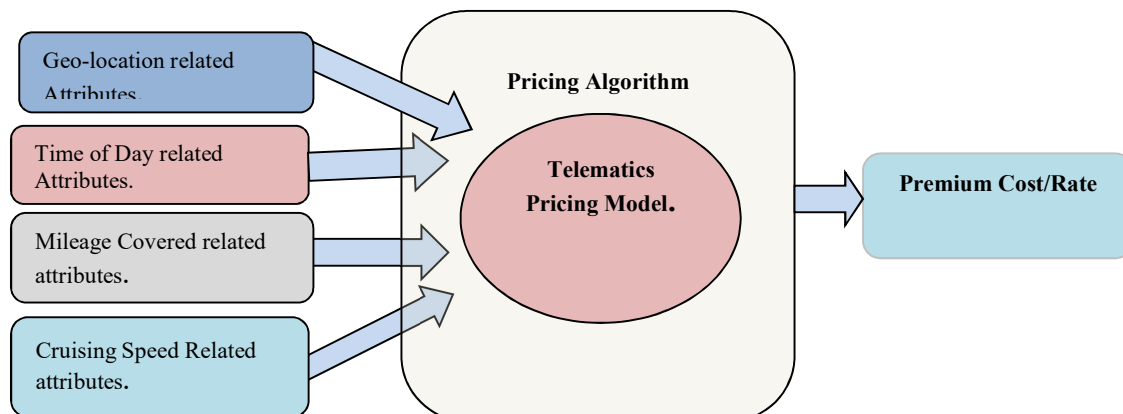

Figure 6: Conceptual Framework of the research.

CHAPTER 3

RESEARCH METHODOLOGY.

This chapter describes the research method used to enable this project's conclusive findings and results. A research methodology is a systematic plan documented for doing a research. There are both Quantitative and Qualitative research methods which include surveys, participant observation, and secondary data collection. A research methodology also addresses and identifies the target population, the sample size as well as describing the variables and determinants of the sampling. We will also cover the methods used in data collection, consider methods of ascertaining the validity and reliability of the research instruments, define the data analysis methods and identify ethical issues that arise in the research.

3.0 Research Design.

Research Design is described as systematic and organized effort to investigate the exact problem to provide a solution (Sekaran 2011). This study is established to provide a Telematics based risk premium billing in the Insurance Industry. This being a field that has had numerous researches conducted out of our current location and Industry (Kenya) we adopt an quantitative research with experimental and descriptive input to provide for the working model and data collection requirements. The motive of descriptive research is to enhance familiarity with the phenomena and to formulate a more specific research problem after gaining additional insights into the subject. This is the case with Telematics industry in Kenya. We collect data from Insurance Companies for this research since currently, there has been a concerted effort to develop Insurance product based on Telematics. Given that, these products rely 100% on the functionality of the Telematics devices, it gives the ideal field of study from which our hypothesis and feedback can be developed.

3.1 Sample Size and Field Justification.

Leading edge technologies and innovative solutions are not always wholesomely adopted by all the insurance companies in Kenya at once. Therefore, having noted that Telematics is largely being adopted in Insurance, the sample population for this research will be the leading Insurance Companies with their respective head offices in Nairobi that provide Motor Insurance as a product to their clients. This forms a good sampling size and criteria as it is wholesome inclusive and with a sample size of 10% it can be considered to be a representative of the target population.

With a total of 55 registered insurance companies in Kenya, of which 10% of this should be adequate (Mugenda & Mugenda 2003), which is 5 listed insurance companies with their head offices in Nairobi.

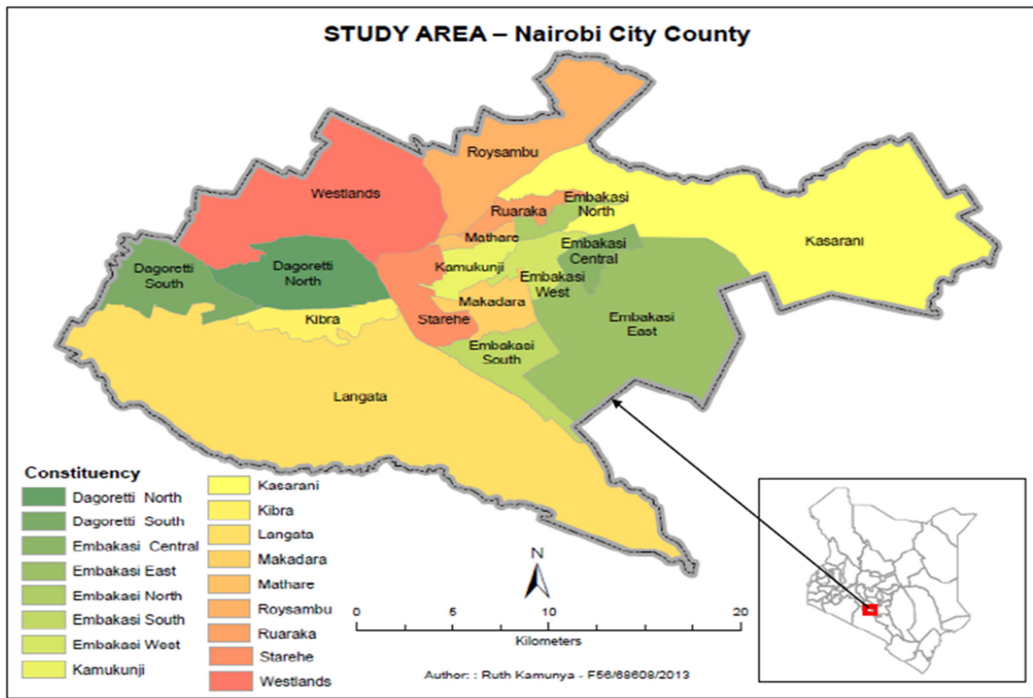

Figure 7: A Map illustration of Nairobi County, the area of study.

Source:

3.2 Data Source & Tools.

Data to be used in this research will be obtained from various sources representing different attributes and stakeholders to provide a framework and conclusive results for modeling the prototype. We expect to request for related resources from the following governmental Agencies to assist in creating an informed decision on the workings and possible implementation of the solution. The following are the data requirements and the related sources that we shall be using.

No.	Dataset Characteristics	Function	Data source
1	Crime Report Statics and Clustering for Nairobi Region	To provide insights into potentially crime prone areas for appropriate ranking.	National Police Service
2	Road classification & Accident Rating Prevalence	To provide relevant on how various roads are in relation to driving on them	National Transports and Safety Authority and the Kenya Urban Roads Authority.
3	Standard General Insurance Motor Rating Premium	The relevant and related Underwriting Data in the insurance industry	Insurance Regulatory Authority and a selected few Insurance companies.
4	Population Demographic Distribution – Nairobi County	Related Population dispersion in various sub-counties and the county	National Bureau of Statistics
5	Nairobi Road Network (All	Related Road Network	Nairobi City County

	Classes – AC & D).	classification and status	and the Kenya Urban Roads Authority.
6	Administrative Boundaries	Related Administrative Boundaries for crime reporting and classification	Ministry of Interior, Nairobi City County and the Survey of Kenya
7	Road Accidents Statistics	Accident occurrence and Reporting Statistics	Kenya Police, County & Sub-County Hospitals
8	Motor Vehicle Theft & Recovery	Instances of Motor vehicle Theft and Occurrence for respective regions	Police Divisions & Stations.
9	Claims & Claims Data	Related Claims Data for Motor Vehicles	Kenya Police & Insurance Regulatory Authority.

3.3 Sample Data Input, Manipulation, Verification and Validation

Based on the data collected, a series of inputs, data manipulation and verification was done to provide various test variables on simulation to depict the various roads, geo-location, time of day and the relationship within the context of possible claims and affinity for risk.

3.4 Prototype Development Design.

The development of a prototype addressing or meeting our functionalities will depend upon the output provided from the data collected and the continuous iterative review and improvement process. We will use defined structured development methods which encompass a set of activities, methods, best practices, deliverables and automated tools that contribute to the structured development of this system. Using a consistent defined methodology in Software engineering has been noted to be a key contributor in software development through the following;

- Creates efficiencies that allow optimum resource allocation.
- Produces consistent documentation that reduces lifetime costs of maintaining systems.
- Promotes quality.

The following Diagram Illustrates the Development Methodology to be adopted in the Prototype Design.

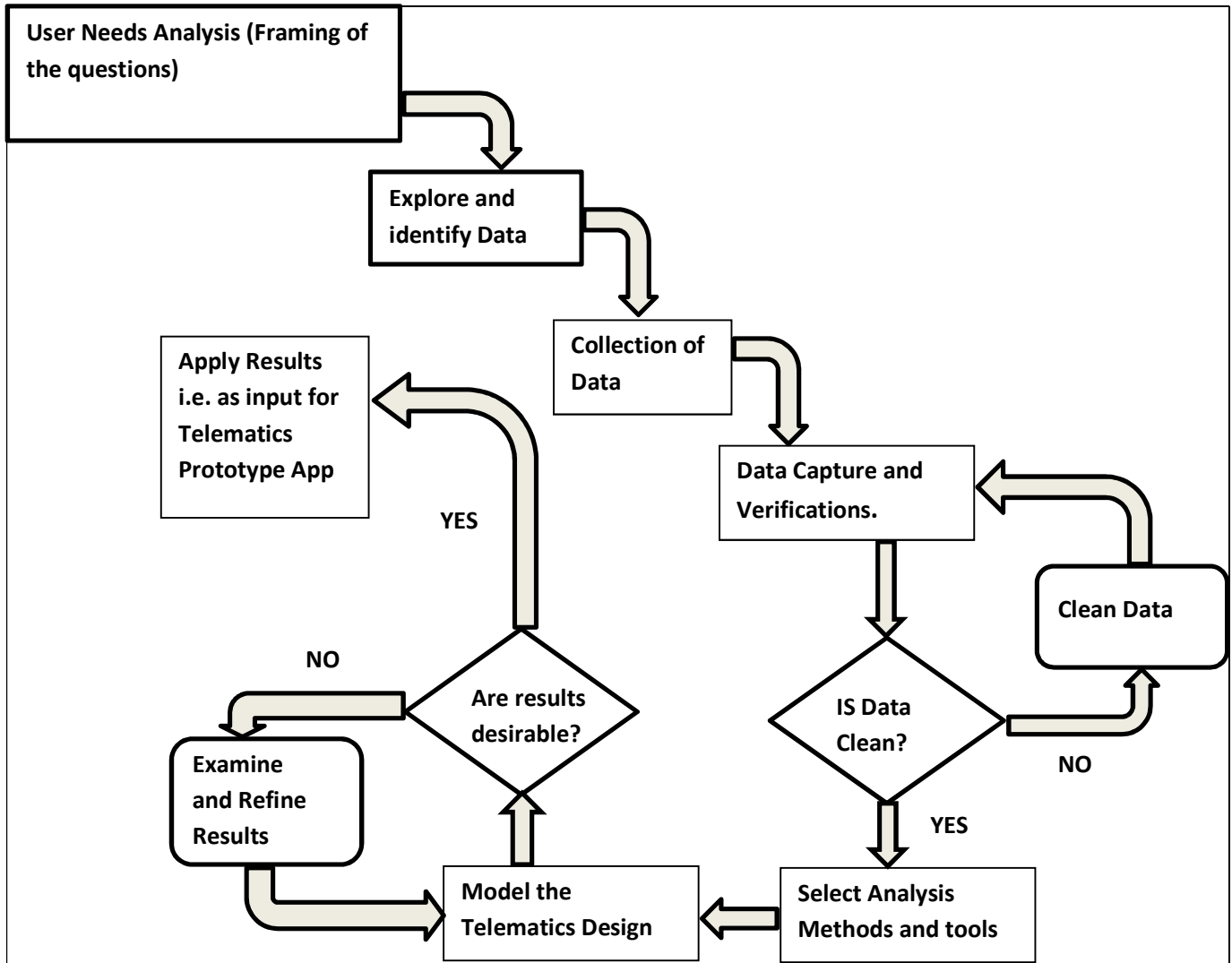

Figure 8: The following phases will be for part of the development design methodology.

3.5 Planning.

At this stage we basically review and brainstorm and clearly understand the fundamental processes of why, how and the desired methodology of the envisaged system should be built. As a developer, it gives us an understanding of how as a project lead, we will go about in developing the system.

3.5.1 Conceptualization.

This is the Initial phase of any system design process. Based on the literature review and the deficiencies and positive attributes identified in the current market offerings, the aim is to carry out an elicitation to obtain an understanding of the problem by following a user centered approach based on use cases (J Rambaugh, I. Jacobson, The Unified Modeling Language, 1999). A use case corresponds to a description of the sequence of actions needed to produce an observable result useful for an actor.

3.5.2 Functional Analysis.

Understanding user and functional requirements is an integral part of any system development and it's critical to the success of the specific system (M.Maguire et al 2002; User Requirements Analysis) and contributes largely to the general acceptance of the system. Considering that Telematics is not a mature technology, problems anticipated at this phase include;

- Perceived thinking's based on the current Telematics set-up and lack of innovations.
- Addressing Challenges that are unforeseen by unstructured data.
- User unaware of what they envisage the system to address.
- What will the system do, who and when will it be used.

This will be done using the following process based on the finding of the literature review and information from the industry stakeholders and data sources.

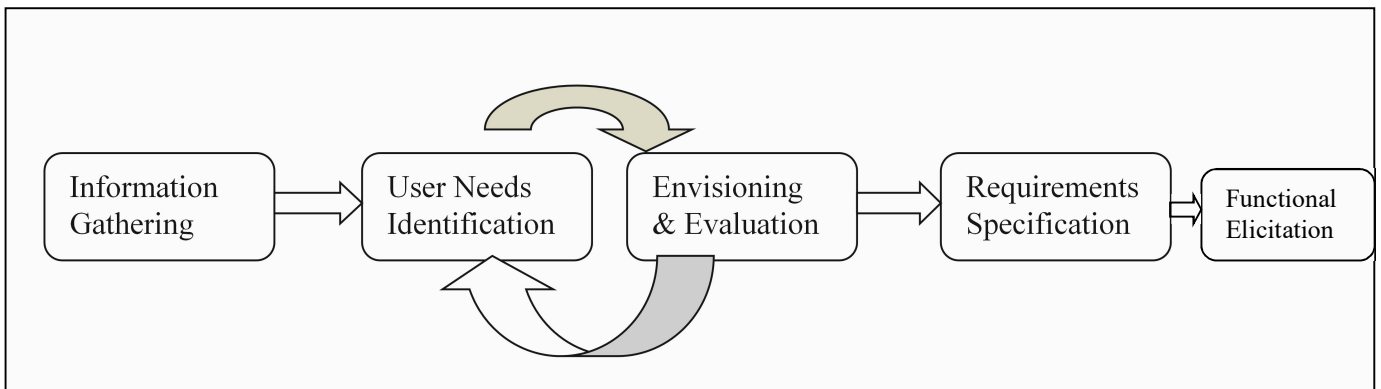

Figure 9: Functional Analysis.

3.5.3 Design.

The design phase takes as an input from the Functional Analysis into a design Model ready to be implemented and proving an indicative direction on how it will accomplish the overall objective. At this point we determine the architecture of the intended Telematics Model. We review the design model and having done comparative functional analysis to the current market solutions and the

perceived weaknesses. It's at this phase that we decide how the system operates in terms of the hardware, software and the current CAN – OBDI II infrastructure. We also define the user interface, forms and reports to be used including specific programs, databases and file types. This should have be an improvement from previous systems.

The following are the design steps that will be considered for the development.

- Design Strategy – Outsource or do it personally.
- Architecture Design – Hardware, Software and Network Infrastructure that will be used.
- Database and File Specifications – These documents will define what and where and how to store data.
- Program design – Defines what programs need to be written and what they will do (Use cases, Functions and Modules).

3.5.4 Implementation.

This is the longest stage in any project delivery initiative. It involves putting into actualization the development of the intended system. It also involves coming up with user interface screens based on described models defined in the use cases and to be able to test the output of the system based on the functional needs. A core aspect of security which forms a basic functional objective of this research has to be demonstrated that it has either been achieved or otherwise.

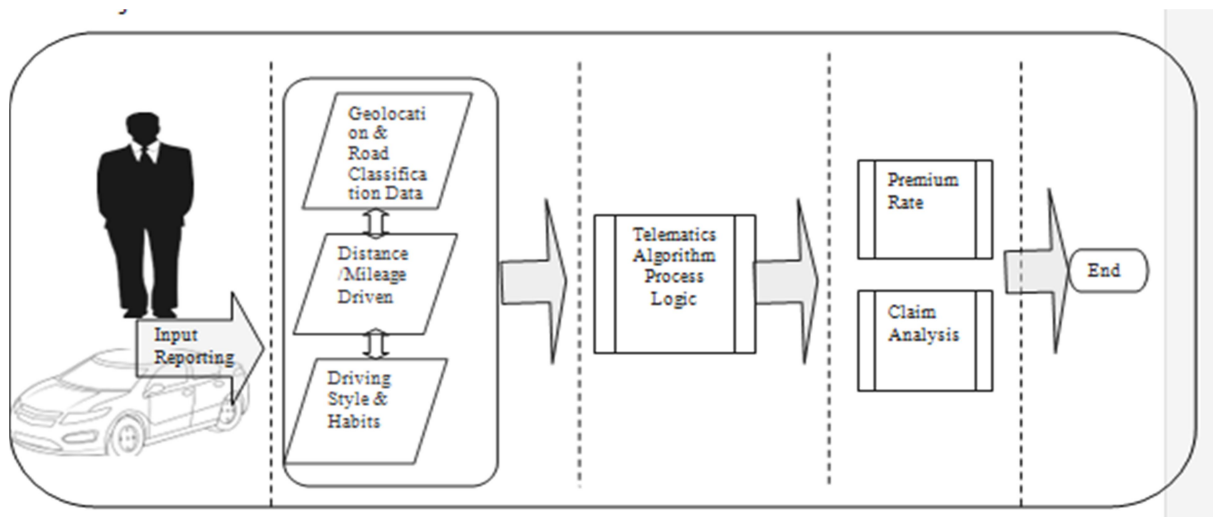

Figure 10: Implementation Design overview.

At this stage, the assessment of user and prototype data sets required for telematics risk assessment and segmentation are defined. Various dataset on Geo-location, Road Status and calibration, time of day/night travels form responds are combined using an algorithm based an identified risk to plot the possible risk indices. It's also at this stage that Data cleansing exercise is carried out by removing unnecessary data and generating the necessary variables to be used in the prototype.

3.6 Why this Methodology.

This methodology will enable us to build a functional system or prototype that demonstrates alienation of weaknesses identified in the current conventional premium calculation methods. It also gives us the ability to demonstrate adherence to defined structured of System Development Lifecycle and employing fully mature and tested techniques which facilitates modularity in the development

3.7 Functional DFD of the Implemented Logic.

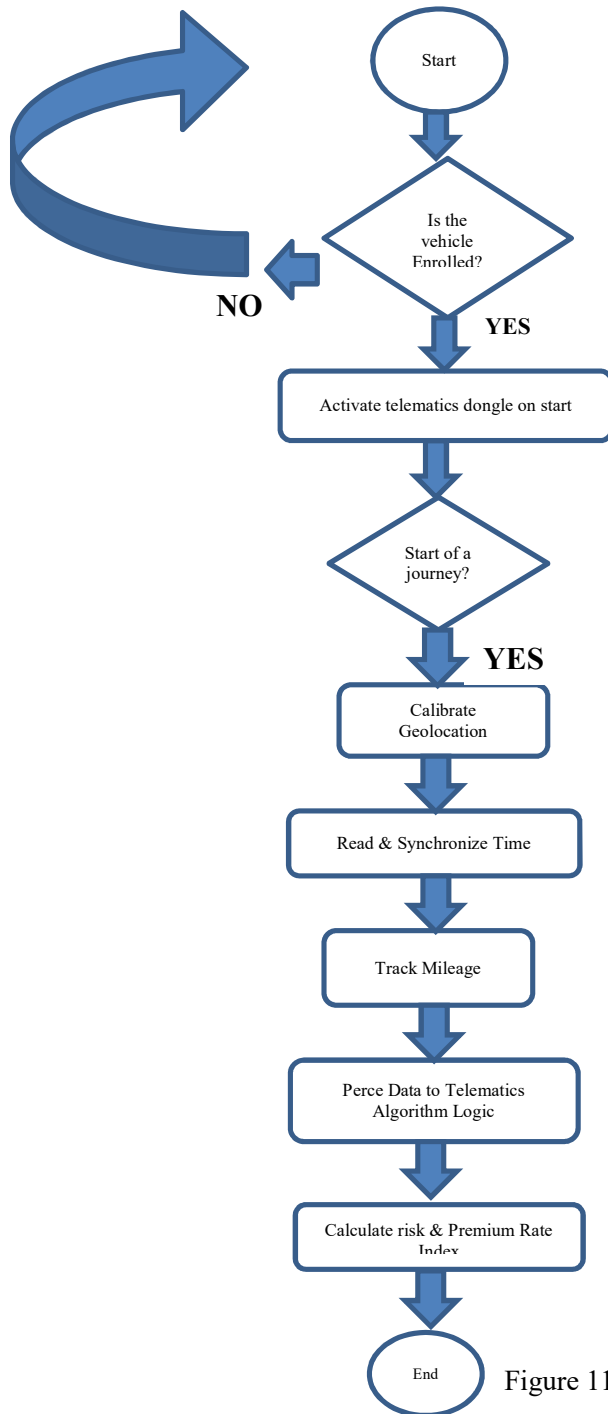

Figure 11: Functional DFD of the Implemented Logic.

The Telematics System prototype is developed based on PHP & MySQL Database Back-end. The system picks up data and the related parameters form the data input generated from the datasets collected from the various stakeholder's and using an indicative rating based on the risk profiling of the various geo-location, Road states and time of drive, it generates the conceptual logic of the appropriate risk. For the prototype to function and provide for the desired parameters, the drivers details and motor vehicle has to be fitted with the telematics dongle. Details of the Mathematical model and the actuarial logic and the system are articulated in the following chapter (Chapter 4) as part of the research findings and results.

3.8. Requirements Budget.

Below is the tentative Project Budget to be expensed in carrying out the research for this project.

S. No.	Item Description	Estimate Cost (Kshs.)
1	HP Laptop & Related Software.	100,000
2	Communication Costs	5,000
3	Internet Costs	5,000
4	Data Collection and Travelling costs	15,000
5	Stationery Costs	5,000
6	Other costs & Incidentals	25,000
	Totals	155,000.00

3.9. Project Schedule.

Below is a tentative project Schedule in delivering the project.

ACTIVITY	COMPLETE	May				Jun				Jul				Aug			
		WK1	WK2	WK3	WK4	1	2	3	4	1	2	3	4	1	2	3	4
Project Proposal	97%																
Preparation of development tools	50%																
Data Collection	10%																
Prototype Design and Testing	00%																
Prototype Implementation	00%																
Evaluation	00%																
Final Report Writing	10%																

CHAPTER 4

RESULTS, FINDINGS AND DISCUSSION.

4.0. Results – Preamble.

As reviewed in the literature review, it has been studied that the current Insurance rating and pricing model in the country provides only a single risk value to all underwriters across the country as a basis of their risk rating and underwriting. This Chapter presents the research project findings for risk rating and pricing based on Telematics. We provide descriptive statistics and data sets from the field justified by the scope of the project and also based on the project variables and the inputs. We also present the output and outcome of the prototype and related feedback and we deduce what the results means for the body of knowledge, stakeholders in the Insurance Industry and as well as future researchers in this field.

In order to provide accurate and real time data, it is important to understand that technology in itself does not exist in a vacuum and the environment and the “agents” in the environment and ecosystem have a direct influence to the fully functioning of the technology (in this the prototype) which directly impacts the working prototype. In this case therefore as earlier indicated in the literature review, there were various agents and stakeholder “agents” from which data collected could directly impact the full functionality of the working of the prototype. We therefore collected Demographic data and Population dispersion within the scope and sphere our research, Administrative boundaries to justify infrastructure installations, roads and related crime and build up areas to assist in providing reliable pattern on the risk profile of our subject motorists and related risk.

No.	Dataset Characteristics	Function	Data source
1	Crime Report Statics and Clustering for Nairobi Region	To provide insights into potentially crime prone areas for appropriate ranking.	National Police Service
2	Claims & Claims Data	Related Claims Data for Motor Vehicles insurance and policies.	Insurance Companies & Insurance Regulatory Authority.
2	Road classification & Accident Rating Prevalence	To provide relevant status of roads in relation to driving on them	National Transports and Safety Authority and the Kenya Urban Roads Authority.
3	Standard General Insurance Motor Rating Premium	The relevant and related Underwriting Data in the Motor insurance industry	Insurance Regulatory Authority and a selected few Insurance companies.
4	Population Demographic Distribution – Nairobi County.	Related Population dispersion in sub-counties and the county to relate to societal facilities	National Bureau of Statistics
6	Administrative Boundaries	Related Administrative Boundaries for crime reporting and classification	Ministry of Interior, Nairobi City County and the Survey of Kenya
7	Road Accidents Statistics	Accident occurrence and Reporting Statistics	Kenya Police, County & Sub-County Hospitals
8	Motor Vehicle Theft & Recovery	Instances of Motor vehicle Theft and Occurrence for respective regions	Police Divisions & Stations.

Location Map of Nairobi County.

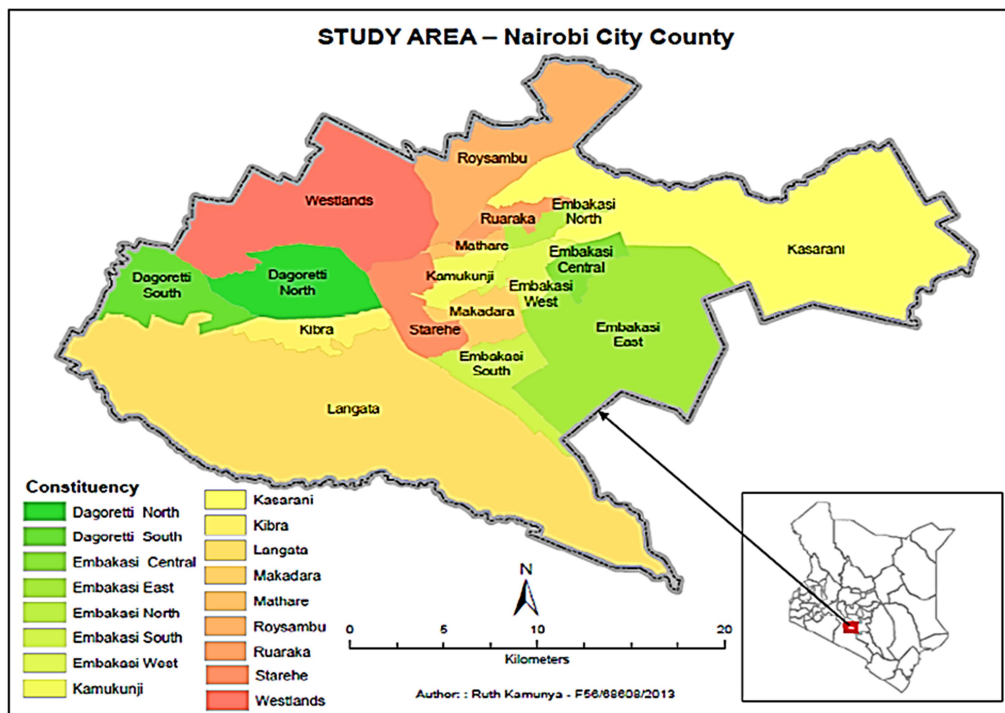

Figure 12: Administrative Boundaries of Nairobi County.

4.1. Nairobi County

Insurance Industry as a filed and especially at the claims perspective which is the ultimate objective of underwriting that requires the input of government institutions in validating the occurrence of the incident or any claim provided. It is therefore important that we were to get data related to the County’s Administrative Boundaries – for validating reported cases of accidents and Claims (an insurance claim has to be accompanied by a Police Abstract) in order to understand the prevalence of the cases in each of the said administrative unit.

Sub-County	Divisions	Locations	Sub-locations
Starehe	3	6	12
Kamukunji	3	9	18
Kasarani	2	11	24
Makadara	3	5	11
Embakasi	3	6	13
Njiru	3	6	10
Dagoreti	3	8	16
Langata	4	7	16
Westlands	3	6	15

Source: Ministry of Interior and Coordination of National Government, Nairobi City – 2016

4.2. Administrative Boundaries and Infrastructure.

The population dispersion and distribution in the County also impact on the risk profile of the subject user and area. Therefore it is imperative that the related matrices to it be considered as a player in the risk profiling of the use-case as it relates to telematics insurance underwriting.

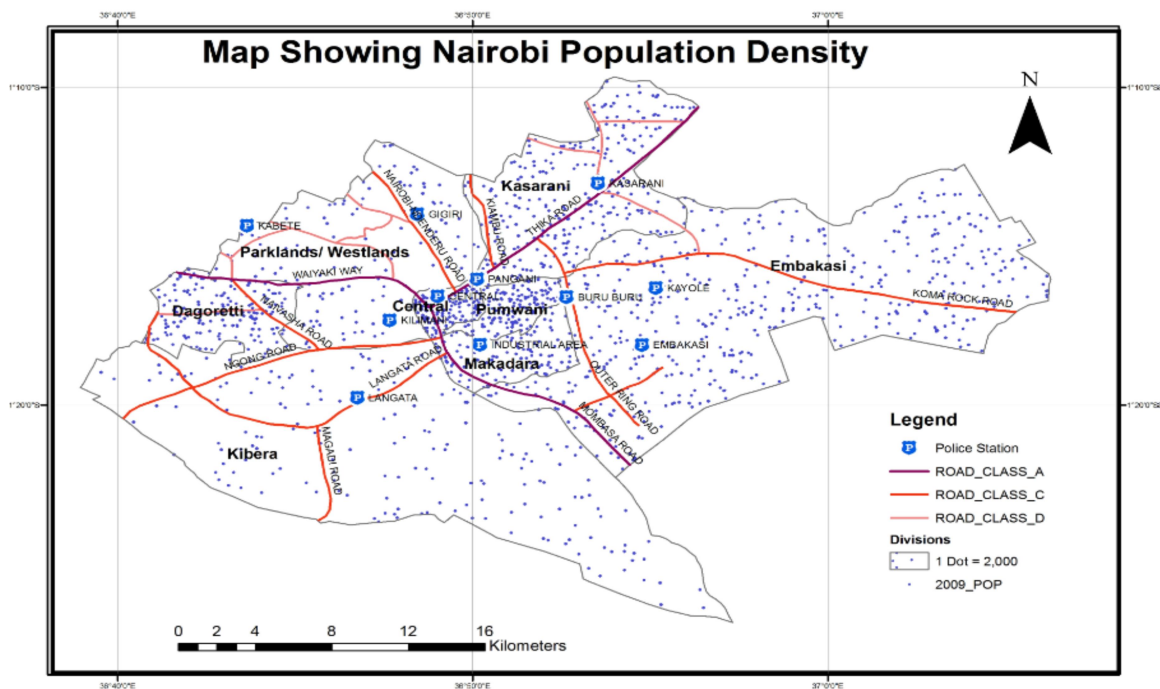

Figure 13: Population Dispersion of Nairobi County.

4.3 Police Post & Motor-Vehicle Related Data.

Divisions	Vehicle Crime-Related Reported Data (Annually)	Approximate Population	No of Police Posts & Stations.
Starehe (CBD, Ngara, Pangani, Ziwani, Kariokor, Landmawe, Nairobi South)	229	315,798	4
Kamukunji (Pumwani, Eastleigh – North & South, Airbase & California)	865	301,133	4
Kasarani. (Clay City, Mwiki, Kasarani Njiru & Ruai.)	350	604,468	6
Makadara (Maringo, Hamza, Viwandani, Harambee, Makongeni & Mbotela)	1040	251,438	
Embakasi (Both South, North, Central, East & West) – Eastlands. <ul style="list-style-type: none"> ▪ South – Imara Daima, Kwa Njenga, Kwa Reuben Pipeline, Tasia & Kware. ▪ North – Kariobangi North, Dandora Area 1, Dandora Area 2, Dandora Area 3, Dandora Area 4, ▪ Central – Kayole North, Kayole North Central, Kayole South, Komarock, Matopeni/Spring/vally* ▪ East – Upper Savanna, Lower Savanna, Embakassi, Utawala & Mihingo. ▪ West – Umoja 1, Umoja 2, Mowlen, Innercore & Kariobangi South. 	659	1,203,507	11
Ruaraka. (Babadogo, Utalii, Mathare North, Lucky Summer & Korogocho)	480	243,918	7
Dagoreti.(South & North) (Kilimani, Kawangware, Gatina, Kileleshwa – Mutu-ini, Ngando, Riruta, Uthiru, Ruthimitu, Waithaka)	187	428,451	4
Langata (Karen, Nairobi West, Ngumo, South C, Nyaho & High Rise)	569	532,782	5
Westlands (Kitusuru, Parklands, Highridge, Karura, Kangemi a& Mountain View)	484	521,232	5
Roysambu (Roysambu, Garden Estate, Muthaiga, Rigerwayas, Githurai, Kahawa west, Zimmerman, Kahawa.	349	325,681	6
Mathare (Mathari Hospitala, Mabatini, Huruma, Ngei, Mlango Kubwa & Kiamaiko)	217	328,129	5

4. 4. Road Classification & Set-up.

Nairobi County being the capital City of Kenya has all the roads either intersecting through it or providing vital connections to other links roads. These roads are classified as follows.

Road Classification	Type	Description	Functional Purpose	Research Comments.
Road Class A		International Trunk Roads.	Links International Important Centers and cross international Boundaries	This are highly maintained roads in good condition but very busy.
Road Class B		National Trunk Roads	These roads link Nationally Important centers.	This are also highly maintained roads in good condition but very busy.
Road Class C		Primary Roads	A road that links provincially important centers to each other or to higher class roads.	Moderately maintained in Nairobi county but those in other counties are poor.
Road Class D		Secondary Roads	Link locally important centers to each other	Periodically maintained.
Road Class E		Minor Roads.	Any link to a minor Centre	
Road Class SPR		Special Roads.	This are special assigned roads e.g. Government Road, Tea Road, wheat road, Sugar Road etc.	
Road Class U		Unclassified roads.		

The Nature, status and classification of the road is directly related to how it is maintained and which also has a direct relationship to the nature of the risk attributed to the motorist who will travel or use the road. It goes without a saying a good highly maintained road roads and highways translates to better roads signage, driving ability, lesser accidents and therefore lesser risk to the road users. This therefore has a direct impact to the telematics risk aspect of the underwriting insurance company.

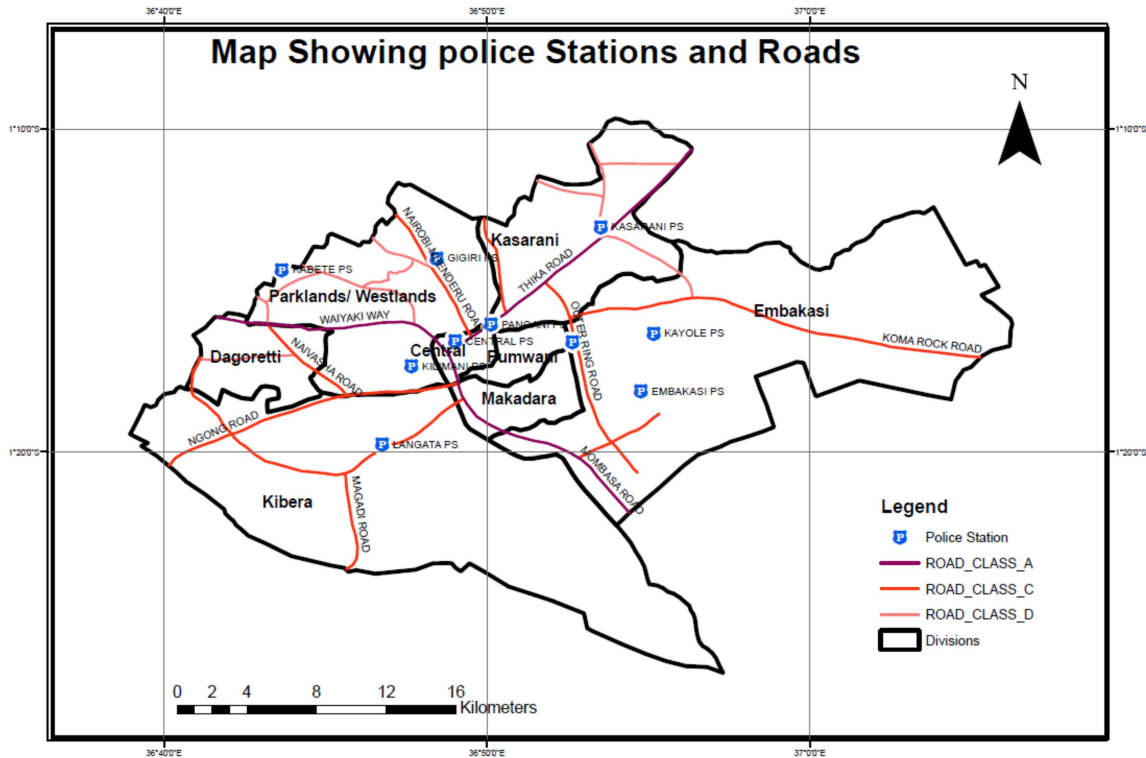

Figure 14: Police Stations & Roads Network in Nairobi County.

4.5 Time of Day & Related Mileage Trips on the Road.

Divisions OR Town	Distance in Kilometers from CBD	Road Classification (Type) Used	Approximate Mileage Per Month
Starehe	9.7 KM	Muranga Road. Thika Superhighway	705.6
Kamukunji	1.6 KM	River Road, Ronald Ngala Stree, Moi Avenue	316.8
Kasarani.	11.6 KM	Thika Superhighway. Outering Road	796.8
Makadara	4.3 KM	Uhuru Highway	446.4
Embakasi	14.7 KM	Mombasa Road, ENTERPRISE Road	945.6
Ruaraka.	6.7 Km	Thika ROAD (Class A) Outering Road Class B	561.6
Dagoreti	29 kM	Lanagat Road Southern Bypass.	1632
Langata	17 Km	Langata Road Southern Bypass.	1056
Westalands	4.2 KM	Muranga Road. Kipande Road	441.6
Roysambu	14.7 Km	Thika Superhighway	945.6
Mathare	11.7 km	Thika Superhighway	801.6

4.5.1 Relationship of the Mileage & and Risk Vector.

AVERAGE MONTHLY MILEAGE TRIPS CLOCKED			
No.	Speed Cluster (KM/Month)	Risk Rating	Comment
1	0 - 1,050	0.5	Low Risk
2	1,051 -1,550	0.75	
3	1,551 - 2,050	1	
4	2,051 - 3,050	1.25	
5	More than 3,050	1.5	High Risk

4.5.2 Relationship of the Weekly Time of Day Travel & Risk Vector.

WEEKLY TRAVEL TIME					
No.	Weekly Travel Time.	Start	End	Risk Rating	
1	Monday - Friday	5:00:00 AM	9:00:00	0.5	Low Risk
2	Monday - Friday	15:00:00 PM	12:00:00	0.75	
3	Friday - Sunday	9:00:00	17:00:00	1	
4	Saturday - Sunday	12:00:00	20:00:00	1.25	
5	Saturday - Sunday	12:00:00	12:00:00	1.5	High Risk

4.5.3 Sample Geo-Location Clustering for Risk Vector Index and Profile.

No.	Sub-county Name	Av. Risk Rating	Wards	Ranking
1	Dagoretti North	2.74	Gatina Ward.	2.7
			Kabiro Ward.	3
			Kawangware	3
			Kileleshwa Ward.	2.6
			Kilimani Ward.	2.4
2	Dagoretti South	2.22	Uthiru Ward	2.2
			Mutuini Ward	2.3
			Riruta Ward	2.3
			Ngando Ward	2.2
			Waithaka Ward	2.1
3	Embakassi Central	3.16	Kayole Ward	3.2
			Matopeni Ward	3.2
			Kayole South	3.2
			Kayole Central	3.2
			Komarock South	3

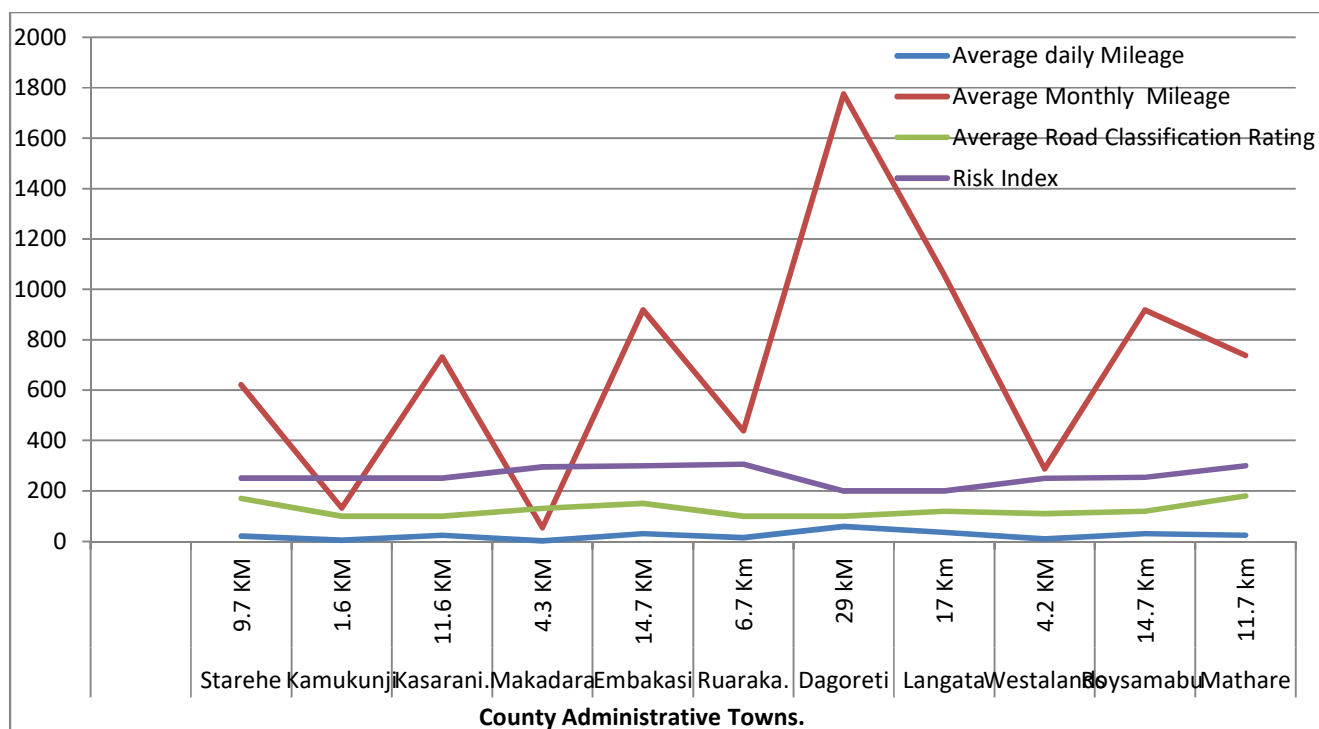

Figure 15: Relative Mileage & Township Distance.

The Graph above extrapolated relationship between the County Administrative towns, their cumulative distance from CBD, Average Monthly Mileage for a normal Car owner and related risk ranking based on the various variables.

In rating and ranking the geo-location of the motor – vehicle users, various socio economic variables were considered which are based on basic infrastructural facilities that impact on the livelihood and risk perception of a location. These were as follows;

- Roads used by the Driver and their condition.
- Classification of the respective Roads by the national Roads board of Kenya.
- Infrastructural facilities available in the residential neighborhood where the motorist lives (e.g Hospitals, Police stations, Schools, Shopping centers, Lit Walkways etc.).
- Proximity or availability of an integrated low income informal settlement.
- No of Entertainment spots (Bars & Clubs).
- Known Presence of Organized criminal gangs.
- The respective population (controlled development) of the location.

4.6 Insurance Industry Matrices and Factors.

There are Fifty One Insurance Companies in the country and of which 35 (Thirty-five) of them offer various types of motor insurance. The motor private insurance which was the basis of this research is reported to have recorded a 7.68% growth from the previous year in gross written premium. However, it's alarming to note that in the same period, the class of business still had an underwriting loss of Kshs 3.43 Billion as compared to 2015 which was at Kshs. 3.36 Billion.

Nairobi County accounted for 72.8 % of the total insurance premium in the industry irrespective of the class of business. This represented a drop from 80.4% which had been reported in the previous year.

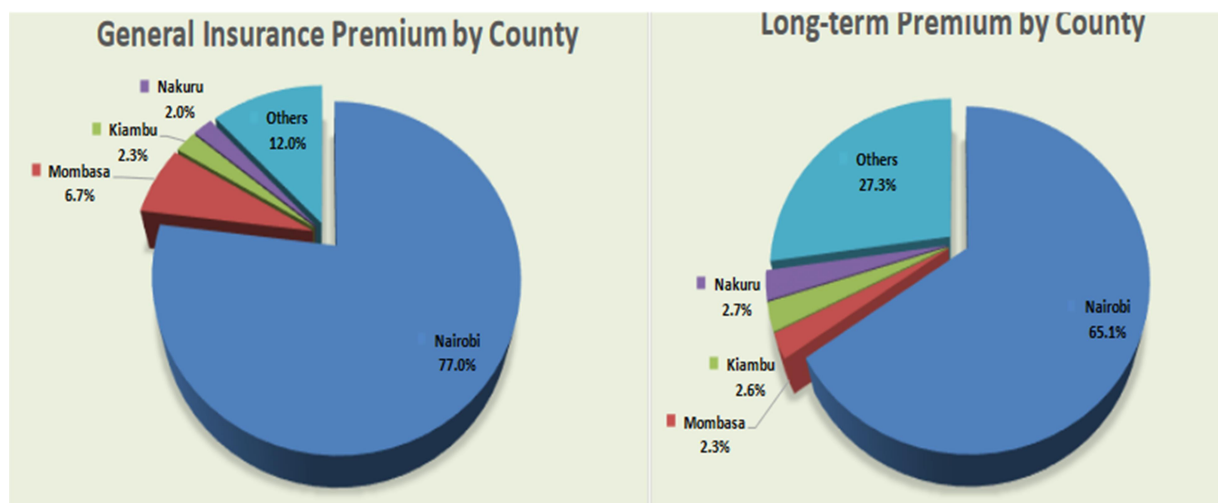

Figure 16: Nairobi County's Insurance Premium.

Of the subject insurance companies dealing with Motor-Private insurance cover of which our research was based on, we were able to carry out a total of 37 written questionnaires which were submitted to various key stakeholders in the respective companies (Two questionnaires were submitted to a large scale Taxi company with fitted telematics , insured by one of the company) . This included the following personnel roles;

- Claim Managers.
- Product Development Manager.
- Underwriting Manager.
- IT Manager.

4.7 Feedback and Response Overview.

In evaluating and reviewing the response in a follow-up to the questioners shared, a total of 33 forms were comprehensively filled in, details provided and returned. As per Mugenda and Mugenda (1999), this rate of response is above the recommended industry research practice of 70 % and therefore considered sufficient and valid.

4.7.1 Research Respondents.

The following table depicts the overall respondents to the shared Questionnaire.

No	Role/Position	Frequency	Percentage Presentation	Feedback Returned	Percentage Response Presentation
1	Claim Managers.	8	22%	7	19 %
2	Innovation & Product Dvlp Manager.	9	24 %	8	21 %
3	Underwriting Manager.	9	24%	7	19%
4	IT Manager.	9	24%	9	24 %
5	Fleet Manager	2	6%	2	6 %
	TOTAL	37	100%	33	89 %

The respondents to the questionnaires as illustrated above demonstrates a well versed selection of the study area and gives credence to the information and data collected.

4.7.2 Maturity of the Insurance Companies studied in relation to the Motor vehicle Industry.

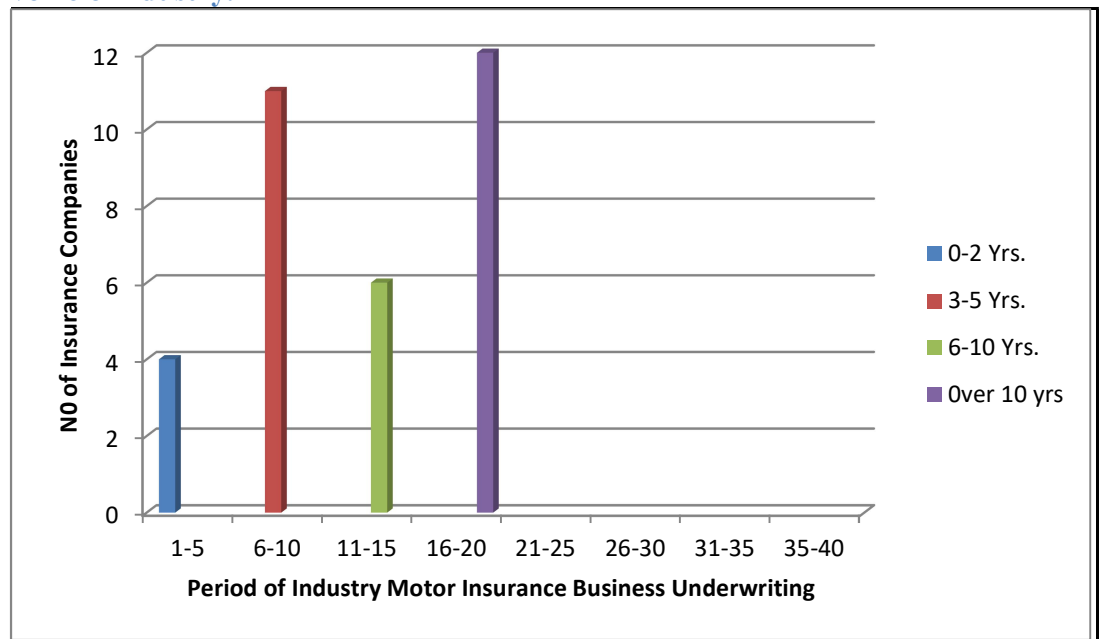

Figure 17: Motor-Insurance Maturity in Industry.

Of the 37 companies in Study, and of which 33 companies responded, over 90 percent have been in the motor vehicle Insurance for over 6 and above years.

4.7.3 Company offers Telematics based Insurance

Of all the Insurance companies surveyed, they all offered an aspect of Telematics based Insurance either directly or indirectly.

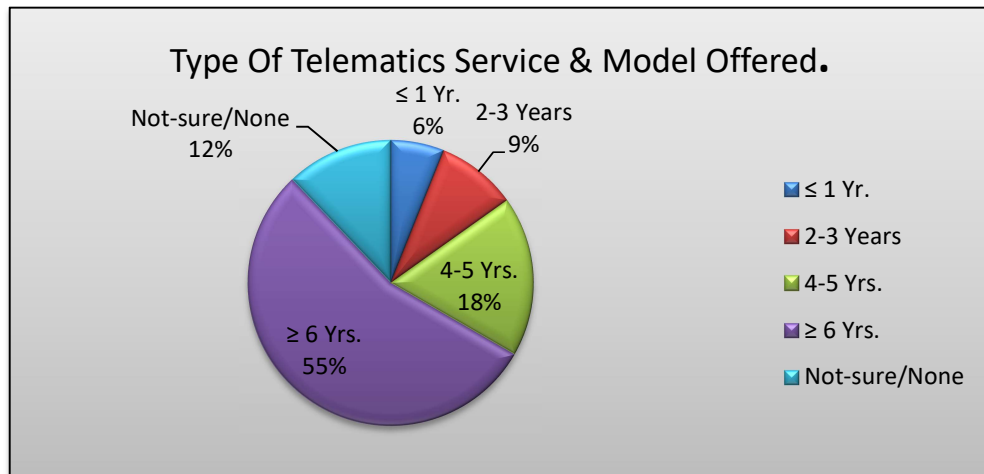

Figure 18: Motor-Insurance Model offered to Market.

From the Above Figure, we are able to note that, all the companies offered a certain type of telematics service on their entire motor insurance product. However, only 9% of them offered the product in a stand-alone ability where it is purely used for the risk rating. A majority of the firms used the Telematics dongle and services as a value add to the insurance product. Of the Insurance companies, 66% used the Telematics service as a Fraud deterrent on the claims for investigative purpose, 12 % used it as a Value add for Recovery and rescue , while another 13 % were not sure where it is Installed on their clients cars or not as it is considered privileged information. Of notable finding is the fact that none of the organizations has considered has installed the devices as a PHYD – (0%) (Pay how you drive) concept. It was noted to be intrusive and most of the follow-up answer to this on interview is that no clients want to be monitored how they drive and where they drive to.

4.7.4 Period Organization been offering Telematics.

How long have your Organization been using Telematics Data and Service as part of your insurance products?

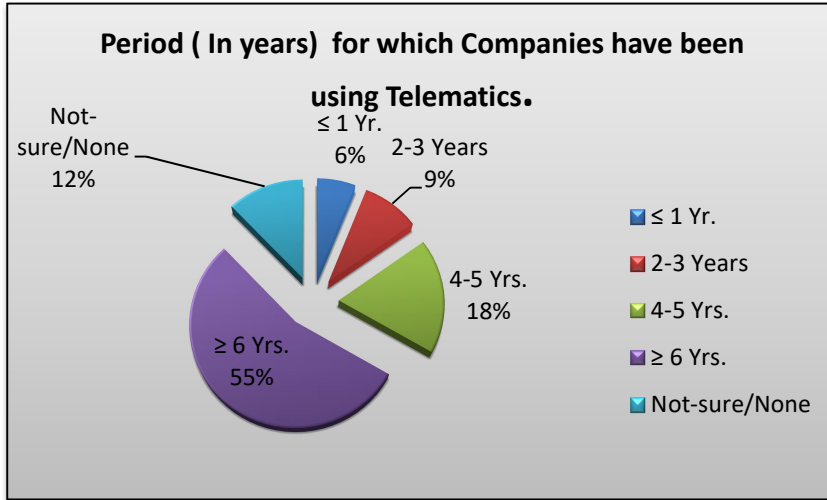

Figure 19: Period Insurance Co. has been using telematics.

Date Requirement for Auto telematics Motor Vehicle Underwriting in comparison to Conventional Underwriting.

No.	Conventional Cover	Telematics Cover.
1	Brand and make of the Car	Brand and make of the Car
2	Evaluated Vehicle value/Cost	Use of the Car
3	Use of the Car	Additional equipment on the car
4	Additional equipment on the car	Geographic location
5	Geographic location	Miles driven per year
6	Previous accident history	Monthly Mileage
7	Driving Experience (Yrs)	Residential Location
8	Drivers Age	Normal Trips of Car
		Time of Day when car is used

How do you rate the reliability of Telematics insurance as a basis of motor vehicle Underwriting compared to Conventional (IRA Rate) Method?

Reliability of Telematics	Frequency	Percentage	Cumulative Percentage
Very Reliable	19	58 %	58 %
Reliable	12	36 %	94 %
Unreliable	0	0%	94 %
I Don't Know	2	6%	100 %
TOTAL	33	100 %	

From the Findings above in which we wanted to know the users perception on the reliability of the Telematics solution as a basis of Insurance Underwriting compared to the conventional model, we are able to deduct that 94 % of the respondents consider it reliable in giving realistic and reliable matrices on loss and claims data in comparison to the conventional way.

Would you do recommend the adoption of Telematics as a basis of motor vehicle underwriting as an insurance Standard?

Recommend the Adoption of Telematics	Frequency	Percentage	Cumulative Percentage
Strongly Recommend	10	30 %	30 %
Recommend	18	55 %	85 %
Unrecommendable	2	6%	91 %
Strongly Unrecommendable	3	9%	100 %
Don't Know/Not Sure.			
TOTAL	33	100 %	

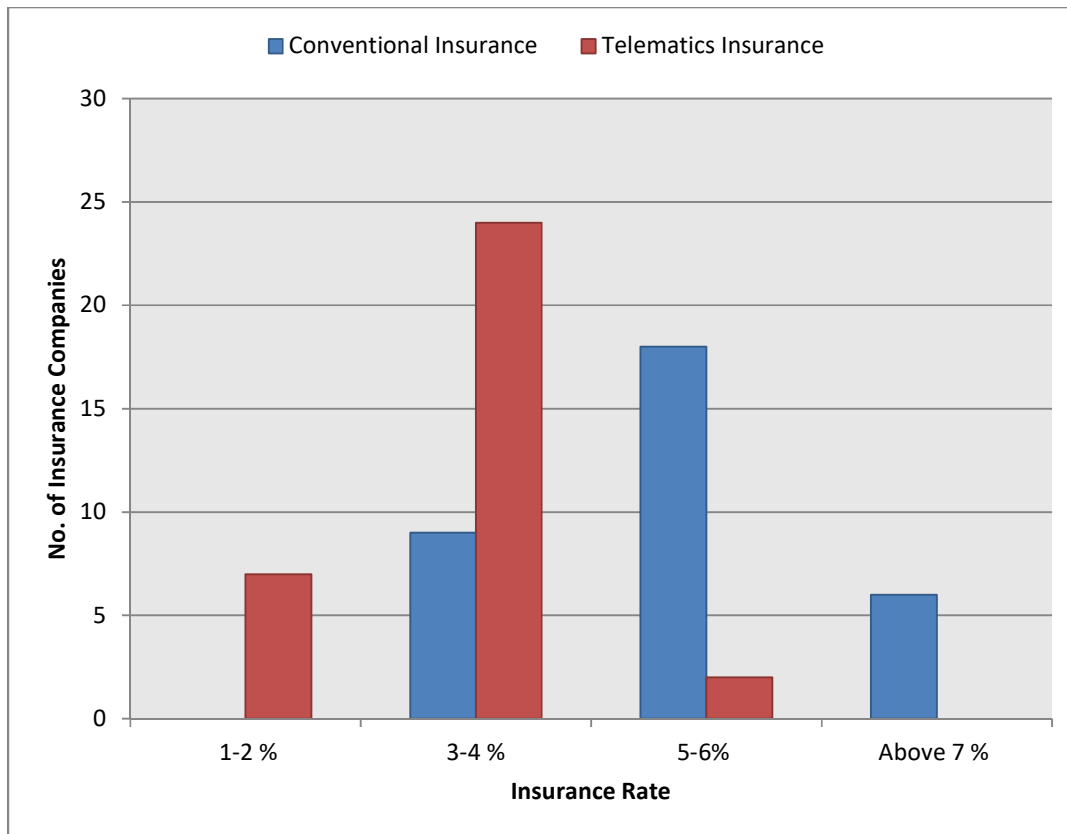

Figure 20: Premium Rate Analysis.

In The above figure it is clear that more insurance companies are willing to extend subsidized and highly discounted rate to motorists who subscribe to telematics insurance in comparison to the conventional model. It is also evident that the rate of underwriting is lower on Telematics based insurance in comparison to the Conventional model

Benefits Associated with Telematics Adoption in Industry.

No.	Functional Benefit of Telematics Adoption on Insurance Industry	Mean	Standard Deviation
1	Telematics Lowers the Risk Associated with Motor Vehicle Loss claim by aiding Motoring, Tracking & Recovery.	4.87	0.37
2	The use of Telematics reduces the claim cost related to vehicle loss & Accident Compensation	4.69	0.64
3	Telematics Insurance Assists the Insurance Company to realistically price the risk based on actual risk indices	4.56	0.72
4	Telematics Insurance Provides a reduced risk premium rate compared to conventional Insurance	4.47	0.51
5	Telematics offers a reduced cost rate	4.41	1.16

According to the results in the table above, most of the respondents agree with the impacts of Telematics Insurance. These factors describe instances where the level of acceptance is very important and their acceptance rating (mean 4.83 for Telematics lower insurance risks, 4.69 for Telematics reduces the claim cost, 4.56 for telematics realistically reduces price risk based index, 4.47 Telematics reduces Premium rate and 4.41 for telematics reduces insurance rates) indicate the factors are very impactful and agreeable the respondents.

How would you rank the impact of Telematics Insurance technology to the insurance industry as a cost/premium control tool?

Telematics Insurance as a Premium Cost Control Intervention.	Frequency	Percentage	Cumulative Percentage
Extremely Significant	15	45 %	45 %
Very Significant	13	40 %	85 %
Significant	5	15%	100 %
No Impact at All	0	0%	
Don't Know/Not Sure.	0	0	
TOTAL	33	100 %	

Finding in the table above reveal that most of the respondents agree that telematics is a a very significant tool and a model in cutting down on insurance costs. 45% of the respondents concur that Telematics is an extremely significant tool in cutting costs, where as 40% agree that it is very significant, 15% accept that it is significant and there were no any respondents who had an differing opinion and therefore they all acknowledge that it has a huge impact in determining cost reduction in premiums cost significantly.

4.8 Simulation Implementation.

This section provides a discussion on the prototype developed and the results based on various simulations in relation to the collected data. It is also important to note the system development tools used the framework and technologies.

- a) Technology & Framework – The Prototype is developed based on Java and an SQL Backend.
- b) Coding – We provide sample code of the prototype an extract and as an appendix attached to the report.
- c) Functional Testing – The Prototype is put into functional processing and testing in order to validate the functionality and its applicability.
- d) User & Installation – The procedure on its use is also provided for any untrained user.
- e) Documentation – User manual has been developed for guiding novice users.

4.9 Programming Language Choice.

The choice of Java as the programming language used was based on the researcher's ability to code in this platform and having worked with it previously.

4.10 Simulation Capabilities.

The prototype simulation and testing was carried out in various aspects and using different variables. It is important to note that the object of the research was to validate and compare the underwriting on a telematics prototype in comparison to a conventional system model and with each model using its basic data as the base of input. This was done under the circumstances and with the researched and of which results are shared earlier.

4.11 Matrix Functionality Testing.

Based on the various identified variables that contribute to the insurance underwriting on a telematics Model, the Prototype was tested in comparison to what the normal based rate would be for a Nairobi county resident who is an average road user who drives to work every morning and back home in the evening.

The results are provided in this chapter as a basis of the research recommendations.

Source Code Algorithm Extract.

```
} elseif ($show_long < 60 * 60) {
    $return = (int) ($show_long / 60) . " minutes";
    if ($isPast) $return .= " ago"; else $return = "{$return} From Now";

} elseif ($show_long < 60 * 60 * 24) {
    $return = (int) ($show_long / (60 * 60)) . " hours";
    if ($isPast) $return .= " ago"; else $return = "{$return} From Now";

} elseif ($show_long < 60 * 60 * 24 * 2) {
    if ($isPast) $return = "Yesterday"; else $return = "Tomorrow";

} elseif ($show_long < 60 * 60 * 24 * 7) {
    $return = (int) ($show_long / (60 * 60 * 24)) . " days";
    if ($isPast) $return .= " ago"; else $return = "{$return} From Now";

} elseif ($show_long < 60 * 60 * 24 * 13) {
    if ($isPast) $return = "Last week"; else $return = "Next week";

} elseif ($show_long < 60 * 60 * 24 * 7 * 4) {
    $return = (int) ($show_long / (60 * 60 * 24 * 7)) . " weeks";
    if ($isPast) $return .= " ago"; else $return = "{$return} From Now";
```

```

} elseif ($show_long < 60 * 60 * 24 * 30 * 2) {
    if ($isPast) $return = "Last month"; else $return = "Next month";

} elseif ($show_long < 60 * 60 * 24 * 30 * 12) {
    $return = (int) ($show_long / (60 * 60 * 24 * 30)) . " months";
    if ($isPast) $return .= " ago"; else $return = " {$return} From Now";

} else {
    if ($isPast) $return = "More than 1 year ago"; else $return = "more than 1 year From Now";
}

return $return;
}
function dayDropdown($name="day", $selected=null)
{
    $wd = '<select class="form-control" name="'. $name. '" id="'. $name. '">';

    $days = array(
        1 => 'Monday',
        2 => 'Tuesday',
        3 => 'Wednesday',
        4 => 'Thursday',
        5 => 'Friday',
        6 => 'Saturday',
        7 => 'Sunday');
    /*** the current day ***/
    $selected = is_null($selected) ? date ('N', time()) : $selected;
}

```

Vehicle Risk Calculator Variable Update

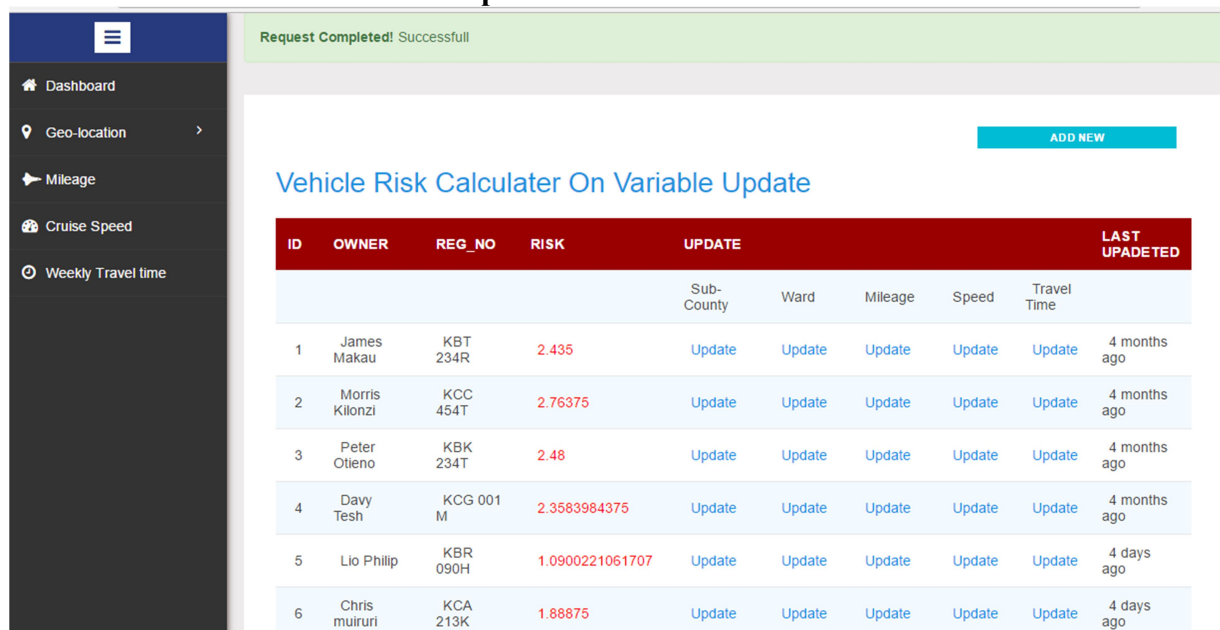

Figure 21: Sample Prototype Screen-Capture

4.12 Models Results & Objective Discussion.

Based on the regulatory industry under which the Insurance regime operates, there are various factors that should be considered even as we seek to find the optimum cost effective and competitive rate and is so doing we validate the findings that the telematics based insurance rate is cheaper than the conventional model. In this case therefore, it is imperative to note that certain conditions have to be fulfilled so that our system prototype is within the regulatory regime's controls and also accepted and adopted by industry players. This therefore means that the rate cannot be more than the IRA regulated rate, and nor below or beyond the IRA minimum approved rate and also it cannot be a zero.

The Mathematical function of the logic related to the algorithm can be indicated as below;

Telematics Risk – Risk Upper Limit = TUr

Maximum IRA Rate = IRrMax

Minimum IRA Rate = IRrMin

Telematics Risk – Risk Lower Limit = TLr

The following constraints have to be built into the logic;

The Telematics resultant Rate (Tr) cannot be more than IRA Maximum Regulated Rate (IRrMax) and cannot be less than IRA Minimum Regulated Rate (IRrMin). It should not also be less than 2% (Two Percentage Point) for the business productivity and administrative cost.

Basic Default IRA Rate = 6%

Actual Telematics Variable Rate = AtVr

Geo-location Rate = (GIR),

Time of Day Rate = (TodR)

Mileage Covered Rate = (McR)

Cruising Speed Rate = CsR

Therefore Formulae for risk Premium Calculation =

$$\text{IRrMin (2\%)} + \left\{ \frac{\text{GIR} + \text{GIR} + \text{McR} + \text{CsR}}{4} \right\} \times \text{CV.}$$

Where CV = Car Value.

All Variables must be greater than Zero.

The development of the prototype Model as earlier illustrated considers that all motorists live in various locations and therefore they are exposed to various risk factors and are exposed to different varied infrastructure and social amenities which impact differently on their risk exposure every single day they drive on the road. This solution considered various agents and risk factors in any location. These include roads and infrastructural amenities, police stations and reported cases of related car and motor vehicle crime. Geo-location Population and relative distance covered in a monthly period.

As part of the objective and a point of results discussion is to ensure that we have a competitive insurance environment, free of illegal practices and business undercutting as the underwriting rate is scientifically determined based on real causal data form environmental and telematics data. The model if adopted can greatly improve the uptake of insurance by public and also give insight to insurance companies that assist them to strategize on their risk uptake as well.

The successful outcome of this research sought to answer and validate three main objectives. These were as follows;

1. What Data is required in building a comprehensive Telematics Model in comparison to the data collected in a conventional motor insurance?
2. Can the implementation/adoption of Telematics model & GIS data clearly express the risk vectors of an auto/motor insurance policy?
3. By what percentage decrease/or Increase is the rate derived from Telematics different from the conventional rate?

All this objectives have been addressed by the various findings as demonstrated in the research findings and by a telematics system prototype model which has ranked and clustered the various variables in the telematics ecosystem to appropriately provide a telematics rating for the perceived clients.

In a backdrop of the suspicious nature of Insurance business in Kenya, Motor insurance is one of the businesses that is highly risky in view of the illegal unhealthy competition that goes on in this industry. Infact at the literature review it is important to remind us that we have several companies that have been put under receivership because they cannot afford to service their claims.

The Insurance Regulatory Authority has in several instances attempted to cushion insurers while making motor vehicle Insurance both mandatory and appealing.. However, blanket rates that do not put the geographical aspect of risk into perspective have contributed to blind uptake of high risks that in turn has resulted to numerous claims that add up to unmanageable cumulative claims running insurance companies out of business. One of the main challenges of IRA and AKI is to improve the insurance uptake within the country which is currently at only 3%.

This research has successfully shown that given a certain geographic region, one is able to segment the geographic region into regions of varying risk magnitude. Unique geo-location risk probability ratios can be generated and used in generating of a relative telematics risk premium rate. This research has also shown that the magnitude of risk increases with increase in population. Telematics can also be used to analyze the spread of motor risk not only based on the police stations as control points but also in relation to the roads which in this case are the risk trajectories. Telematics is therefore an important technology which should be adopted uniformly across the industry.. There are a number of advantages that telematics Insurance provides which are listed as follows.

1. Graphical mapping of insurance risk into varying territories
2. More precision in reflecting the actual risk exposure of the Insured and vehicle (Both to Insurance Company and owner).
3. Improved in the uptake of the Insurance Products.
4. Low Acquisition Cost related to customer onboarding.
5. Reduced Operating Expenses.
6. Reduced fraudulent claims.
7. Recovery of Stolen Motor vehicle
8. Product Cost Pricing accuracy and adequacy.
9. Improved Customer and Client Renewal & Retention.
10. Improved Accident Factual Investigation.
11. Increased in Safety and Security.
12. Innovation on products offering.

The potential adoptions of telematics will positively impact the insurance companies. We foresee a possibility where data that mainly affect motor insurance risk is aggregated into a map view enabling some quick analysis that can lead to quick decision making in these organizations. Analysis resulting from the visualized data can be used by insurance companies to understand the spread of risk hence helping insurance companies plan on their risk uptake.

CHAPTER 5

CONCLUSIONS AND RECOMMENDATIONS.

5.0 Introduction.

From the review of the feedback, analysis and data collected and simulation of the prototype the following summary, conclusions and recommendations are soundly made out of this research.

5.1 Summary.

This research findings revealed that already some underwriting insurance companies have already adopted the use of telematics in their underwriting operations, however the use is not fully and exclusively telematics and neither has it been maximized but has been adopted in varied implementations as follows;

- As a value Add-Service (Rescue, Tracking & Recovery).
- As a Claims Investigation Add – on.
- Pay as you Drive Insurance (Mileage based

Most of the interviewed respondent and research subjects were indeed in agreement that telematics adoption as an underwriting technology is a very important cost control tool in insurance premium and risk rating. This demonstrated that in as much as majority of the respondents have confidence on the use of telematics, the impacts as a premium rating tool has not yet been realized. In an effort to demonstrate the functionality of the developed Prototype, we had to segment the city in various risk clustered based on the various risk agents and based on the administrative boundaries. It is important to note that the aspect of a blanket rate to all individuals as a basis of proving cover is way old-fashioned and has no basis as represented by the findings in this research. It was noted that indeed telematics variable under study provided a more realistic risk base for the majority of the customers and clients. It is therefore expected that with the continued appreciation of the technology from those companies that are early adopters and its reduction in the average cost of ownership, Telematics Insurance will be the standard norm of underwriting motor vehicle insurance. This is justified by the response received from the research respondents who have leadership roles in the respective Organizations. This is also justified even further with the number of Organizations that have adopted online platforms as underwriting and marketing platforms for proposal form delivery.

5.2 Research Study Recommendations.

From this research study, it's been demonstrated that indeed, apart from the conventional aspect of IRA guided Insurance motor vehicle underwriting rate, there is indeed environmental , real-time causal data that are a significant contributor to the risk profile being underwritten, and therefore it is imperative that that this be considered in the process. However, it is important to note that its adoption for the few companies that have adopted it, it's yet to be acknowledged as a mainstream product. Several companies have adopted it as a value adds, or an additional risk control solution. From the data analysis and rankings of the risk exposure according to risk indices it has been validated and inferred with absolute measures of the impact.

From this research the following recommendations can be made.

1. The Insurance Regulatory Authority of Kenya (IRA) should review its Underwriting rates to incorporate telematics into the processes and in so doing provide a more realistic rating model that will demonstrate real risk causal data in the Insurance Industry.
2. Insurance Companies also ought to adopt and innovate more technology driven products and re-engineering that will provide competitive atmosphere and business practice that are free from unhealthy undercutting and business practices to foster an environment of growth in the industry.
3. Local Government Institutions and policy leaders and key stakeholders in the Infrastructural sector need to device and adopt efficient are update methods of Handling and collecting data related to key societal and demographics which greatly impact to development decisions and geographical profiling.

Having focused on a single geographical location (Nairobi County), this research forms a basis of an improved research in the same fields which can cover various geographical areas of the country, and include other insurance products or areas of motor insurance. There is indeed great opportunity and ways in which telematics data can be harnessed and utilized. This is not only for the insurance industry but equally for other areas in technology adoption.

References.

1. The Elsevier, 2015 'Telematics System in Usage Based Motor Insurance', Vol 100, 2015 pg. 816-825
2. Insurance Act – 2015. Available from [www.ira.go.ke/attachements/article/60/REVISED INSURANCE ACT 2015.pdf](http://www.ira.go.ke/attachements/article/60/REVISED_INSURANCE_ACT_2015.pdf)
3. Litman, T., Distance-Based Vehicle Insurance: Feasibility, Costs and Benefits - Comprehensive Technical Report, Victoria Transport Policy Institute, 2011
4. Kenya Security Index Report 2015, Available from www.nationalpolice.go.ke/crime-statistics.html?download=26:crime-report
5. The Final 2015 Kenya Road Safety Status Report available at <https://www.google.com/url?sa=t&rct=j&q=&esrc=s&source=web&cd=1&ved=0ahUKEwjteX-9q7WAhVlB8AKHUdfBAsQFggnMAA&url=http>
6. Paefgen J, 2013 Telematics Strategy for Automobile Insurers, I-Lab Whitepaper, University of St. Gallen.
7. Porter, M.E, 1985, Technology as a Competitive Advantage, Journal of Business Strategy , 5 No. 3
8. S.Hushjank et al; 2014, Telematics System in Usage Based Motor Insurance.
9. EY Report, Insurance Industry 2011)– Challenges, reforms and Realignment- 2011
10. Ptolomeus Global Usage Based Insurance Study, 2016: p.58
11. (Ferreira and Minikel , 2010), Progressive Insurance (2005) among other))
12. P. Desyllas, et al ;2013) Profiting from business model Innovation : Evidence form Pay-As-You-Drive Auto Insurance, research Policy 2013
13. (Ferreira and Minikel, 2010) Litman 2011, Laurens et al (1999).
14. William Vickrey (1968).
15. Lindberg et al (2005)
16. Greaves & De Gruyter, 2002.
17. Wolf et al., 2001, 2003; Blanchard et al 2010; Forrest and Pearson, 2005; Stopher et al 2007).
18. (Fano and Gershman, 2002, Thiesse, 2007; Iachello and Hong 2007, Hong et al 2008).
19. K. Koscher, A. Czeskis, F. Roesner, S. Patel, T. Kohno, S. Checkoway, D. McCoy, B. Kantor, D. Anderson, H. Shacham, and S. Savage. Experimental security analysis of a modern automobile. In D. Evans and G. Vigna, editors, Proceedings of IEEE Security and Privacy, pages 447–462. IEEE Computer Society, 2010. see <http://www.autosec.org/pubs/cars-oakland2010.pdf>.
20. Stawomir Jasek, Connected car Security Threat Analysis and Recommendations' , 2015
21. Automotive Telematics; Hughes Systique Corporation (WWW.HSC.COM) 2006.
22. Secure updates in Automotive SYSTEMS; R. Spaan, P. Schwabe 2016
23. K. Koscher, A. Czeskis, F. Roesner, S. Patel, T. Kohno, S. Checkoway, D. McCoy, B. Kantor, D. Anderson, H. Shacham, et al., "Experimental security analysis of a modern automobile," in Security and Privacy (SP), 2010 IEEE Symposium on, pp. 447–462, IEEE, 2010. 5, 11

24. S. Checkoway, D. McCoy, B. Kantor, D. Anderson, H. Shacham, S. Savage, K. Koscher, A. Czeskis, F. Roesner, T. Kohno, et al., "Comprehensive experimental analyses of automotive attack surfaces," in USENIX Security Symposium, San Francisco, 2011. 6, 11
25. C. Miller and C. Valasek, "Remote Exploitation of an Unaltered Passenger Vehicle." http://www.ioactive.com/pdfs/IOActive_Remote_Car_Hacking.pdf, 2015. [Online; accessed 05-June-2015]. 9, 10
26. Transport Telematics – Systemic View ; M Svitek, Z. Votruba T.Zelinka; 2013.
27. Ruugia, S. K. (2014). Application of GIS in auto insurance risk segmentation and rating: a case for Nairobi county (Doctoral dissertation, University of Nairobi)
28. Framework for Security and Privacy in Automotive Telematics – S.Duri,M.Gruteser, X.Liu, P.Moskowitz, R.Perez, M.Singh ,J Tang
29. Yoon, D., Choi, J., Kim, H., & Kim, J. (2008, February). Future Automotive Insurance System based on Telematics Technology. In *Advanced Communication Technology, 2008. ICACT 2008. 10th International Conference on* (Vol. 1, pp. 679-681). IEEE.
30. Handel, P., Skog, I., Wahlstrom, J., Bonawiede, F., Welch, R., Ohlsson, J., & Ohlsson, M. (2014). Insurance telematics: Opportunities and challenges with the smartphone solution. *Intelligent Transportation Systems Magazine, IEEE*, 6(4), 57-70.
31. Goyal, M. (2014). Insurance telematics. *International Journal of Innovative Research and Development*.
32. Ippisch, T. (2010). Telematics data in motor insurance: creating value by understanding the impact of accidents on vehicle use (Doctoral dissertation, University of St. Gallen).
33. Troncoso, C., Danezis, G., Kosta, E., Balasch, J., & Preneel, B. (2011). Pripayd: Privacy-friendly pay-as-you-drive insurance. *Dependable and Secure Computing, IEEE Transactions on*, 8(5), 742-755.
34. Gerardo, B. D., & Lee, J. (2009). A framework for discovering relevant patterns using aggregation and intelligent data mining agents in telematics systems. *Telematics and Informatics*, 26(4), 343-352.
35. Husnjak, S., Peraković, D., Forenbacher, I., & Mumdziev, M. (2015). Telematics System in Usage Based Motor Insurance. *Procedia Engineering*, 100, 816-825.
36. Craig, S. C., & Holbrook, E. (2010). Vehicle telematics. *Risk Management*, 57(5), 37.
37. Wahlstrom, J., Skog, I., & Handel, P. (2015). Detection of Dangerous Cornering in GNSS-Data-Driven Insurance Telematics. *Intelligent Transportation Systems, IEEE Transactions on*, 16(6), 3073-3083.
38. Ruugia, S. K. (2014). Application of GIS in auto insurance risk segmentation and rating: a case for Nairobi county (Doctoral dissertation, University of Nairobi).

Appendix 1

SECTION A: Background information.

1. What position do you hold in the organization?

- IT Manager[]
- Claims Manager[]
- Innovation & Product Development Manager.....[]
- Underwriting Mngager
- Fleet Mnager
- Other (Specify).....[]

2. How long have you worked for the institution (Years).

- Up to 2 years[]
- 3-5 years.....[]
- 6-10 years.....[]
- Over 10 years.....[]

3. How long has the company been Underwriting Motor Private Insurance

- Up to 2 years[]
- 3-5 years.....[]
- 6-10 years.....[]
- Over 10 years.....[]

4. Who are What is the Ownership of the Company

- Local.....[]
- International.....[]
- Both.....[]
- Not aware.....[]

SECTION B.

How long has this company been offering motor vehicle insurance cover?

Up to 2 years.....[]

3-5 years.....[]

6-10 years.....[]

Over 10 years..... []

Have you adopted any technology integrated product in your Motor Vehicle Insurance UNDERWRITING?

YES.....[]

NO.....[]

If Yes, Briefly Explain.

.....
.....
.....
.....
.....

Are you aware of Telematics based Motor- Insurance Product and Underwriting?

YES.....[]

No.....[]

Do you offer any Motor Insurance based on Telematics Data

YES.....[]

No.....[]

If Yes, Which one do you provide?

Pay as you Drive Insurance (Mileage based)..... []

Pay How you Drive Insurance (Acceleration Based)[]

As a value Add-Service (Rescue, Tracking & Recovery)

As a Claims Investigation Add – on.

Not Sure..... []

How long have you been using Telematics as part of your insurance products?

- ≤ 1 year []
- 2-3 Years []
- 4-5 Years. []
- ≥ 6 Years []
- Not Used []

What percentage of insurance rate or value of the motor vehicle does a client pay for a comprehensive motor vehicle cover?

- 1 - 2 % []
- 3-4 % []
- 5-6 % []
- 7-9 % []
- $\geq 10\%$ []

Appendix 2

Insurance Telematics

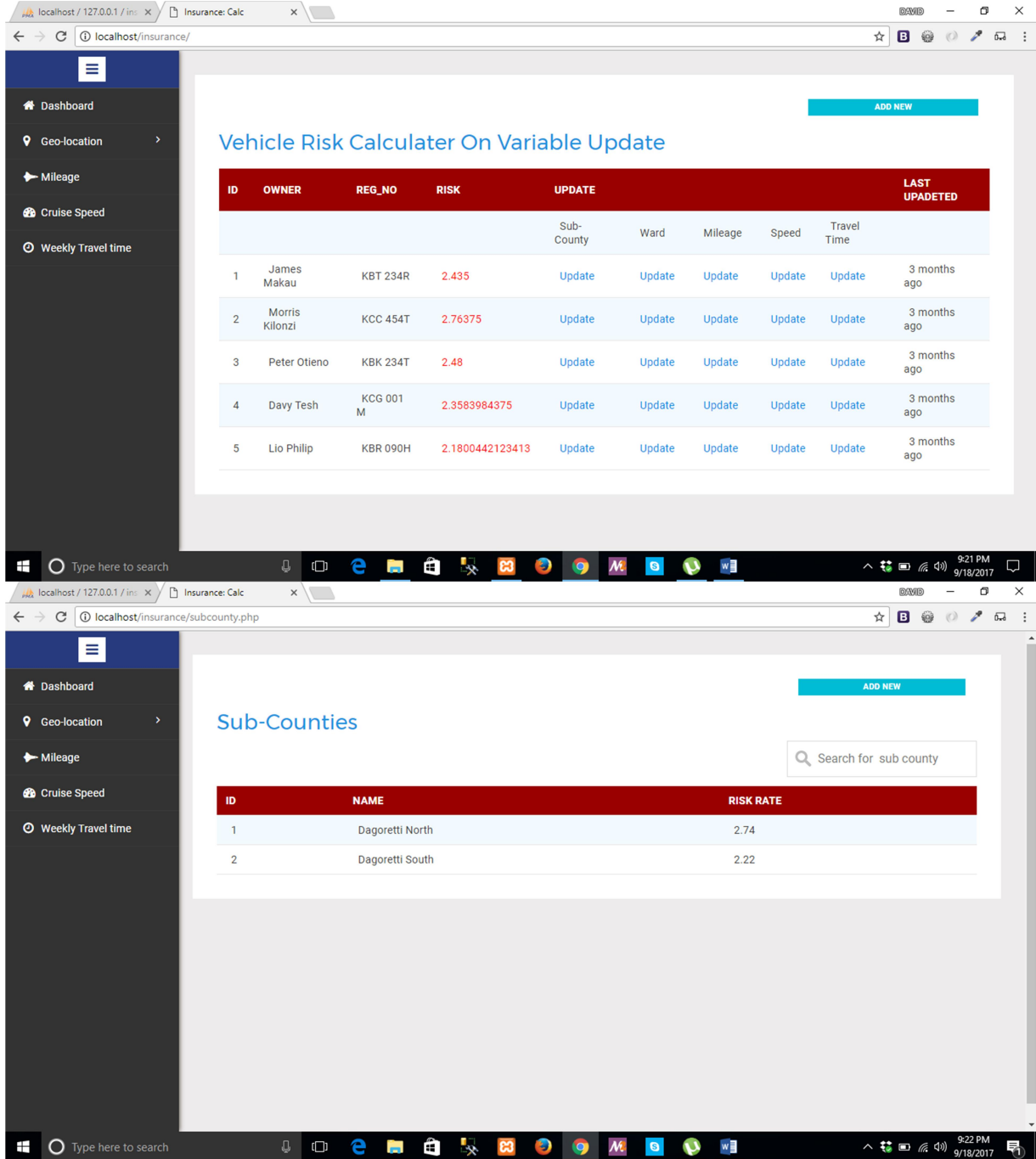

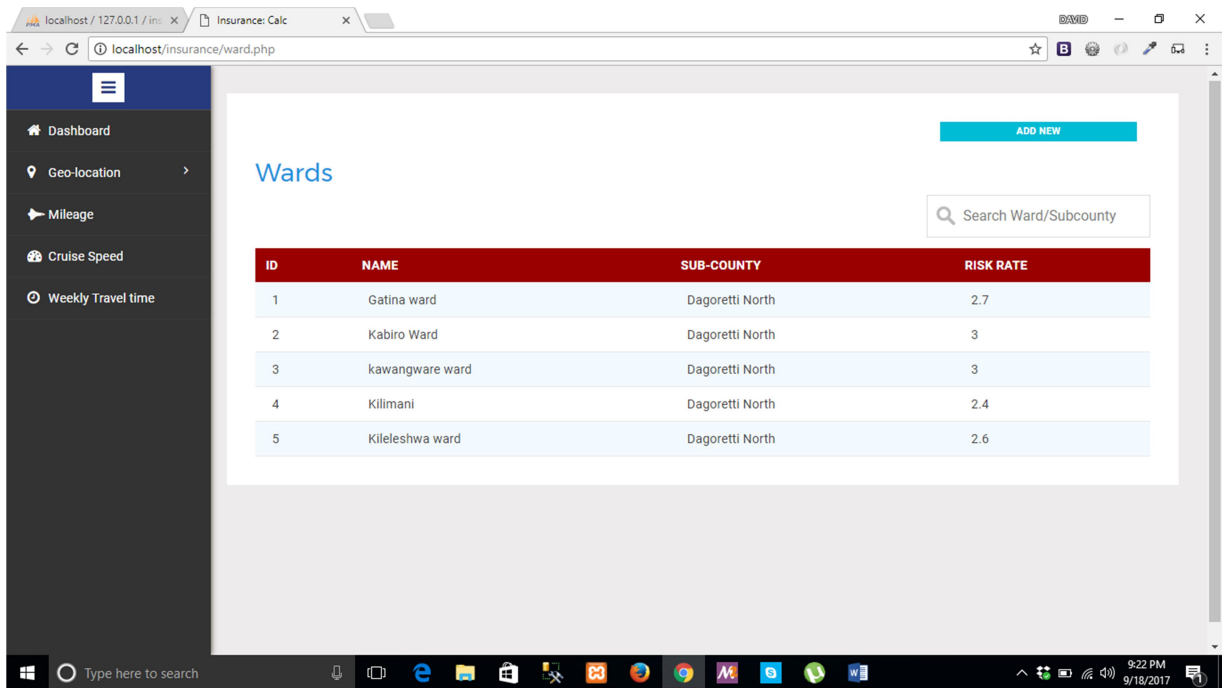
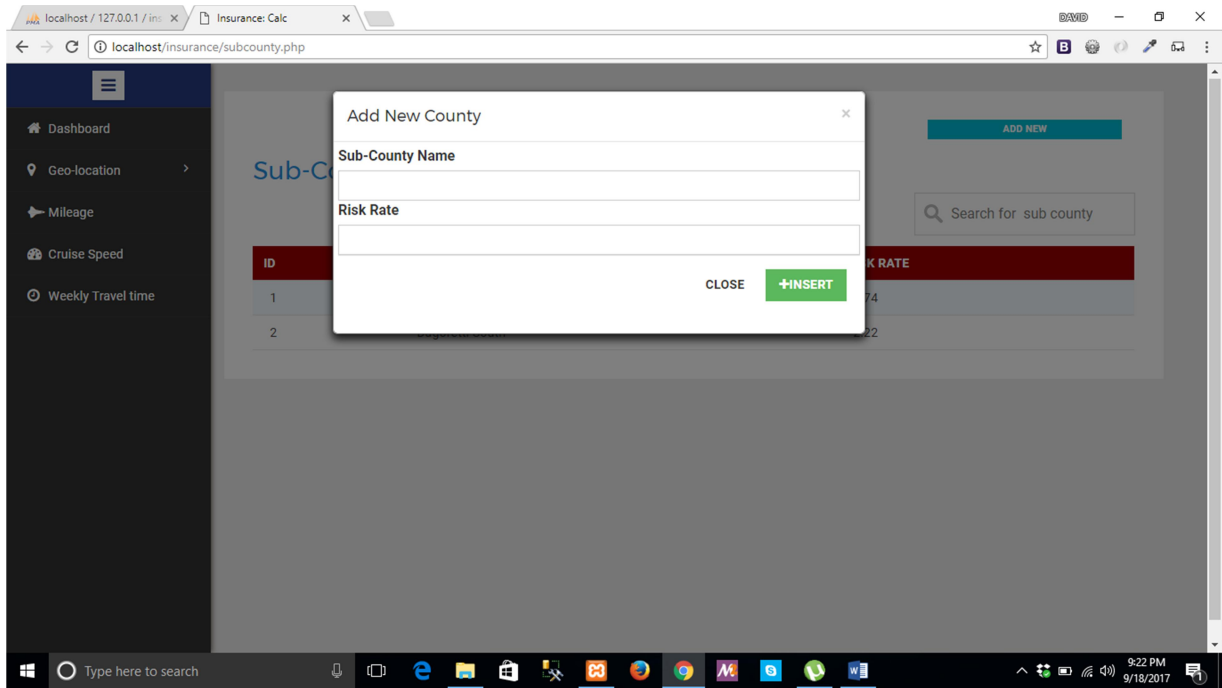

localhost / 127.0.0.1 / ins x Insurance: Calc x

localhost/insurance/ward.php

- Dashboard
- Geo-location
- Mileage
- Cruise Speed
- Weekly Travel time

[ADD NEW](#)

ID	Ward Name	Sub-County Name	RISK RATE
1			2.7
2			3
3			3
4	Killmani	Dagoretti North	2.4
5	Kileleshwa ward	Dagoretti North	2.6

CLOSE
+INSERT

Add New Ward

Ward Name

Sub-County Name

Risk Rate

9:23 PM 9/18/2017

localhost / 127.0.0.1 / ins x Insurance: Calc x

localhost/insurance/mileage.php

- Dashboard
- Geo-location
- Mileage
- Cruise Speed
- Weekly Travel time

[ADD NEW](#)

AVERAGE MONTHLY MILEAGE TRIPS CLOCKED

ID	SPEED CLUSTRE(KM/MONTH)	RISK RATE
1	0-1,050	1
2	1,051-1,550	2

9:23 PM 9/18/2017

localhost / 127.0.0.1 / ins x Insurance: Calc x

localhost/insurance/mileage.php

Mileage Clustering

minimum maximum

Risk Rate

CLOSE +INSERT

Dashboard

- Geo-location
- Mileage
- Cruise Speed
- Weekly Travel time

ID	RISK RATE
1	1
2	2

ADD NEW

Screenshot saved
The screenshot was added to your OneDrive.
OneDrive

9:24 PM 9/18/2017

localhost / 127.0.0.1 / ins x Insurance: Calc x

localhost/insurance/speed.php

AVERAGE SPEED

ID	AVARAGE SPEED-DAILY(KM/H)	RISK RATE
1	0-25	1
2	26-50	1.5
3	51-75	2

Dashboard

- Geo-location
- Mileage
- Cruise Speed
- Weekly Travel time

ADD NEW

9:25 PM 9/18/2017

localhost / 127.0.0.1 / ins x Insurance: Calc x

localhost/insurance/speed.php

Average Speed

minimum maximum

Risk Rate

CLOSE +INSERT

Dashboard

- Geo-location
- Mileage
- Cruise Speed
- Weekly Travel time

ID	RISK RATE
1	1
2	1.5
3	2

9:25 PM 9/18/2017

localhost / 127.0.0.1 / ins x Insurance: Calc x

localhost/insurance/time.php

Weekly Travel Time

ID	DAY OF THE WEEK	START	END	RISK RATE
1	Monday-Friday	0700Hrs	0900Hrs	1
2	Monday-Friday	1500Hrs	1200Hrs	2
3	Friday-Sunday	0900Hrs	1700Hrs	3
4	Saturday-Sunday	1200Hrs	2000Hrs	4
5	Saturday-Sunday	1200Hrs	1200Hrs	5

Dashboard

- Geo-location
- Mileage
- Cruise Speed
- Weekly Travel time

9:25 PM 9/18/2017

localhost / 127.0.0.1 / ins x Insurance: Calc x

localhost/insurance/time.php

Weekly Time Travel

From: MONDAY To: MONDAY

Time From: 0 Time To: 0

Risk Rate:

CLOSE
+INSERT

ID			RISK RATE
1			1
2			2
3			3
4			4
5	Saturday-Sunday	1200Hrs	1200Hrs

9:26 PM 9/18/2017

localhost / 127.0.0.1 / ins x Insurance: Calc x

localhost/insurance/index.php

Update Sub County

- SELECT SUB-COUNTY
- SELECT SUB-COUNTY
- DAGORETTI NORTH
- DAGORETTI SOUTH

ID	OWNER	Sub-County	Ward	Mileage	Speed	Travel Time	LAST UPADATED		
1	James Makau	KBT 234R	2.435	Update	Update	Update	Update	Update	3 months ago
2	Morris Kilonzi	KCC 454T	2.76375	Update	Update	Update	Update	Update	3 months ago
3	Peter Otieno	KBK 234T	2.48	Update	Update	Update	Update	Update	3 months ago
4	Davy Tesh	KCG 001 M	2.3583984375	Update	Update	Update	Update	Update	3 months ago
5	Lio Phillip	KBR 090H	2.1800442123413	Update	Update	Update	Update	Update	3 months ago

9:27 PM 9/18/2017

localhost / 127.0.0.1 / ins x Insurance: Calc x

localhost/insurance/index.php

Dashboard

Geo-location

Mileage

Cruise Speed

Weekly Travel time

Vehicle

ADD NEW

Update Ward

SELECT WARD

SELECT WARD

GATINA WARD

KABIRO WARD

KAWANGWARE WARD

KILIMANI

KILELESHWA WARD

ID	OWNER	County	Ward	Mileage	Speed	Travel Time	LAST UPADATED	
1	James Makau	KBT 234R	2.435	Update	Update	Update	Update	3 months ago
2	Morris Kilonzi	KCC 454T	2.76375	Update	Update	Update	Update	3 months ago
3	Peter Otieno	KBK 234T	2.48	Update	Update	Update	Update	3 months ago
4	Davy Tesh	KCG 001 M	2.3583984375	Update	Update	Update	Update	3 months ago
5	Lio Philip	KBR 090H	2.1800442123413	Update	Update	Update	Update	3 months ago

Type here to search

9:28 PM 9/18/2017

localhost / 127.0.0.1 / ins x Insurance: Calc x

localhost/insurance/index.php

Dashboard

Geo-location

Mileage

Cruise Speed

Weekly Travel time

Vehicle

ADD NEW

Update Mileage

SELECT MILEAGE

SELECT MILEAGE

0-1050 KM/MONTH

1051-1550 KM/MONTH

ID	OWNER	Sub-County	Ward	Mileage	Speed	Travel Time	LAST UPADATED	
1	James Makau	KBT 234R	2.435	Update	Update	Update	Update	3 months ago
2	Morris Kilonzi	KCC 454T	2.76375	Update	Update	Update	Update	3 months ago
3	Peter Otieno	KBK 234T	2.48	Update	Update	Update	Update	3 months ago
4	Davy Tesh	KCG 001 M	2.3583984375	Update	Update	Update	Update	3 months ago
5	Lio Philip	KBR 090H	2.1800442123413	Update	Update	Update	Update	3 months ago

Type here to search

9:27 PM 9/18/2017

localhost / 127.0.0.1 / ins x Insurance: Calc x

localhost/insurance/index.php

Update Average Daily Speed

SELECT SPEED

- SELECT SPEED
- 0-25 KM/H
- 26-50 KM/H
- 51-75 KM/H

Vehicle

ADD NEW

ID	OWNE	Sub-County	Ward	Mileage	Speed	Travel Time	LAST UPADATED		
1	James Makau	KBT 234R	2.435	Update	Update	Update	Update	Update	3 months ago
2	Morris Kilonzi	KCC 454T	2.76375	Update	Update	Update	Update	Update	3 months ago
3	Peter Otieno	KBK 234T	2.48	Update	Update	Update	Update	Update	3 months ago
4	Davy Tesh	KCG 001 M	2.3583984375	Update	Update	Update	Update	Update	3 months ago
5	Lio Philip	KBR 090H	2.1800442123413	Update	Update	Update	Update	Update	3 months ago

Type here to search

9:28 PM 9/18/2017

localhost / 127.0.0.1 / ins x Insurance: Calc x

localhost/insurance/index.php

Update Weekly Travel Time

SELECT TIME

- SELECT TIME
- MONDAY-FRIDAY 0700-0900HRS
- MONDAY-FRIDAY 1500-1200HRS
- FRIDAY-SUNDAY 0900-1700HRS
- SATURDAY-SUNDAY 1200-2000HRS
- SATURDAY-SUNDAY 1200-1200HRS

Vehicle

ADD NEW

ID	OWNE	County	Ward	Mileage	Speed	Travel Time	LAST UPADATED		
1	James Makau	KBT 234R	2.435	Update	Update	Update	Update	Update	3 months ago
2	Morris Kilonzi	KCC 454T	2.76375	Update	Update	Update	Update	Update	3 months ago
3	Peter Otieno	KBK 234T	2.48	Update	Update	Update	Update	Update	3 months ago
4	Davy Tesh	KCG 001 M	2.3583984375	Update	Update	Update	Update	Update	3 months ago
5	Lio Philip	KBR 090H	2.1800442123413	Update	Update	Update	Update	Update	3 months ago

Type here to search

9:29 PM 9/18/2017

Appendix 4

WEEKLY TRAVEL TIME				
No.	Weekly Travel Time.	Start	End	Risk Rating
1	Monday - Friday	7:00:00 AM	9:00:00	1 Low Risk
2	Monday - Friday	15:00:00 PM	12:00:00	2
3	Friday - Sunday	9:00:00	17:00:00	3
4	Saturday - Sunday	12:00:00	20:00:00	4
5	Saturday - Sunday	12:00:00	12:00:00	5 High Risk

AVERAGE SPEED			
No.	Average Speed Velocity (Daily) - KM/H	Risk Rating	
1	0 - 25	1	Low Risk
2	26 - 50	1.5	
3	51 - 75	2	
4	76 - 90	3	
5	90 -120	4	
6	More Than 120	5	High Risk

AVERAGE MONTHLY MILEAGE TRIPS CLOCKED			
No.	Speed Cluster (KM/Month)	Risk Rating	
1	0 - 1,050	1	Low Risk
2	1,051 -1,550	2	
3	1,551 - 2,050	3	
4	2,051 - 3,050	4	
5	More than 3,050	5	High Risk

Appendix 5.

COMPARATIVE USAGE BASED VARIABLES.

1. Nairobi County Geolocation Clustering;

No.	Sub-county Name	Av. Risk Rating	Wards	Ranking
1	Dagoretti North	2.74	Gatina Ward.	2.7
			Kabiro Ward.	3
			Kawangware	3
			Kileleshwa Ward.	2.6
			Kilimani Ward.	2.4
2	Dagoretti South	2.22	Uthiru Ward	2.2
			Mutuini Ward	2.3
			Riruta Ward	2.3
			Ngando Ward	2.2
			Waithaka Ward	2.1
3	Embakasi Central	3.16	Kayole Ward	3.2
			Matopeni Ward	3.2
			Kayole South	3.2
			Kayole Central	3.2
			Komarock South	3
4	Embakasi East	3.06	Mihango Ward	3.2
			Lower Savanaah	3.2
			Upper Savannah	3
			Utawala	2.9
			Embakasi Airport	3
5	Embakasi North	3.46	Dandora I	3.4
			Dandora II	3.4
			Dandora III	3.4
			Dandora IV	3.4
			Kariobangi North	3.7
6	Embakasi South	3.12	Pipeline Ward	2.9
			Kware Ward	3
			Kwa Njenga Ward	3.4
			Kwa Reuben Ward	3.4

			Imara Daima Ward	2.9
7	Embakasi West	3.22	Mowlem Ward	2.8
			Kariobangi South	3.7
			Umoja I Ward	3.2
			Umoja II Ward	3.2
			Mowlem Ward	3.2
8	Kamukunji	2.76	Eastleigh Airbase	2.8
			California	2.6
			Eastleigh North	2.8
			Eastleigh South	2.8
			Pumwani Ward	2.8
No.	Sub-county Name		Wards	Risk Rating Ranking
9	Kasarani	2.54	Clay City	2.2
			Kasarani .	2.4
			Mwiki Ward.	2.8
			Njiru Ward.	2.6
			Ruai Ward.	2.7
10	KIBRA	2.96	Laini Saba Ward	3
			Makina Ward	3
			Lindi Ward	3
			Sarang'ombe Ward	3
			Woodley Ward	2.8
11	Langata	2.08	Mugumoini Ward	2
			Karen Ward	1.8
			Nairobi West	2.2
			Nyayo High Rise	2.4
			South C Ward.	2
12	Makadara	2.95	Harambee Ward	2.7
			Makongeni	3.2
			Maringo/Hamza	3.2
			Viwandani	2.6
13	Mathare	3	Huruma	3
			Kiamaiko	3
			Mabatini	3

			Hospital	3
			Mlango Kubwa	3
			Ngei Ward	3
14	RoySAMBU	2.54	Githurai.	2.2
			Kahawa	2.4
			Kahawa West	2.8
			Roysambu	2.6
			Zimmerman	2.7
15	Ruaraka	3.06	Babadogo	3.2
			Korogocho	3.2
			Lucky Summer	3
			Utalii	2.9
			Mathare North	3
16	Starehe	2.5	Kariokor	2.6
			Nairobi Central	2.8
			Nairobi South	2.6
			Ngara Ward	2.4
			Land Mawe.	2.2
			Pangani Ward	2.4
17	Westlands	2.5	Karura	2.2
			Kitisuru	2.2
			Mt. View	2.8
			Kangemi	2.6
			Parklands	2.7