

**TENSIONS IN TEACHER MANAGEMENT AND GOVERNANCE OF PUBLIC
SCHOOLS UNDER KENYA'S POST 2010 LEGAL FRAMEWORK: A CASE STUDY OF
KAKAMEGA COUNTY**



UNIVERSITY OF NAIROBI
LUBENGU KENNEDY ECHESA
G62/8147/2017

*A Research Project submitted in partial fulfilment of the requirements for the award of the
degree of Master of Laws of the University of Nairobi.*

OCTOBER 2018

DECLARATION

I, **KENNEDY ECHESA LUBENGU**, declare that this is my original work and that the same has not been presented to any institution of higher learning for the award of a diploma, degree or post-graduate qualifications.

Signature..... Date.....

KENNEDY ECHESA LUBENGU

G62/8147/2017

This project has been presented for examination with my authority as the university supervisor.

DR. NKATHA KABIRA

Signature..... Date.....

DEDICATION

I dedicate this project to my late papa, Wilfred Echesa Wa-Lubengu and my two mothers; the late Grace Masakhwe Temesi and mama Tabitha Masai Temesi. They are the source of my knowledge and determination. To my papa and mama Grace, your souls rest in peace, to Mama Tabitha, you forever remain the source of my strength.

ACKNOWLEDGEMENTS

First and Foremost, I thank the Almighty God whose strength and wisdom has seen me come this far. When I graduated with my Bachelor of Laws on 22nd of September, 2017, I promised those who turned up for my graduation that I would pursue Master of Laws as a matter of priority and invite them for a graduation in December 2018. Pursuing a Master of Laws in a record fifteen months is no walk in the park. In God's name, I have kept the promise!

Secondly, I wish to sincerely thank my supervisor, Dr. Nkatha Kabira. She is the silent voice running through this project. Her academic guidance and commitment to duty as a supervisor is beyond reproach.

To my siblings, Chuma, Onyango, Otaba, the late Omina, Etemesi, Awinja, Nerima, the late Sabeti, Milly Okola and Nanjira, you remain a blessing.

I am grateful to my fiancée, Maureen Audrey Wabala Orembo for giving me ample time while writing this project. Whenever the going got tough, she kept me in the race.

To my brothers and friends Julius Kweyu Mukwe, Sammy Ogolla, Joseph Bwaks and Barasa Opaki whose regular encouragement gave me the energy to conclude this project in time, I am grateful. It is rare to get friends who truly believe in one's ability, but you've proved your worth.

To my cousins Protus Induswe Opaki, Robina Ateya, Elizabeth Makomere and Schwarz Josephat Naman Namatsi whose houses served as academic prisons in the process of writing this project, be blessed.

To Lilian Malesi, Jacqueline Linda, Jay Washiali, Faith Masila and Diana Ndung'u, thank you for helping me type and proofread this work. To my niece Mercy Corazon Wa-Mummy, your final proof reading and edition was not in vain. When you eventually begin your academic writing, count on my guidance.

TABLE OF CASES

Attorney General vs. Kituo cha Sheria & 7 others [2017] eKLR

Bett Francis Barngetuny & Another vs. Teachers Service Commission & Another [2015] eKLR

County Government of Nyeri vs. Cabinet Secretary, Ministry of Education, Science and Technology & Another [2014] eKLR

Daniel Kimondo Mutemi vs. Teachers Service Commission [2017] eKLR

Elimu Yetu Coalition vs. Teachers Service Commission & 2 Others, Petition No. 131 of 2015
(Unreported)

George Amara Osodo vs. Teachers Service Commission [2017] eKLR

John Kabua Mwai & 3 Others vs. Kenya National Examination Council & 2 Others [2011] eKLR

Judith Mbaya Tsisiga vs. Teachers Service Commission [2017] eKLR

Kenya National Union of Teachers vs. Attorney General & 4 others [2016] eKLR

Lorna Amunga Eshimuli vs. Teachers Service Commission [2017] eKLR

Mohamed Fugicha vs. Methodist Church in Kenya & 3 Others [2016] eKLR

Mohamed Frigicha vs. Methodist Church in Kenya (suing through its registered trustees) & 3 others [2016] eKLR

Republic vs. Teachers Service Appeal Tribunal & Another Ex parte Alfred Mwiti Obed [2012]
eKLR

Seventh Day Adventists Church (East Africa) Limited vs. Minister for Education & 8 Others [2014]
eKLR

Seventh Day Adventist Church (East Africa) Limited vs. Ministry for Education & 3 Others [2017]
eKLR

Teachers Service Commission vs. Joseph Wambugu Nderitu [2016] eKLR

TABLE OF KENYA LEGISLATION

STATUTES

Basic Education Act, No. 14 of 2013

Children Act, Chapter 141 of Laws of Kenya

Constitution of Kenya 2010

Education Act, Chapter 211 of Laws of Kenya (Repealed)

Kenya Institute of Curriculum Development Act No. 4 of 2013

Kenya National Examinations Council Act No. 29 of 2012

Persons with Disabilities Act No. 14 of 2003

Sexual Offences Act No. 3 of 2006

Teachers Service Commission Act, Chapter 212 of Laws of Kenya (Repealed)

Teachers Service Commission Act No. 20 of 2012

REGULATIONS

Basic Education Regulations, 2015 LN 39/2015

Teachers Service Commission Code of Regulation for Teachers, 2015 LN 196/2015

Teachers Service Commission (Code of Conduct and Ethics for Teachers) Regulations 2015 LN
162/2015

TABLE OF INTERNATIONAL CONVENTIONS

Convention on the Rights of the Child (1989)

Convention on the Rights of Persons with Disabilities (2006)

International Covenant on Economic, Social and Cultural Rights (1966)

ILO Minimum Age Convention (1973)

UNESCO Convention against Discrimination in Education (1960)

Worst Forms of Child Labour Convention (1999)

TABLE OF REGIONAL CONVENTIONS

African Charter on the Rights and Welfare of the Child (1990)

African Charter on Human and Peoples Rights 1981(1981)

TABLE OF FIGURES

Figure A: Governance of schools and teacher management under Education Ordinance of 1924

Figure B: Governance of schools and teacher management under Education Ordinance of 1931

Figure C: Governance of schools and teacher management under District Education Boards Ordinance of 1934

Figure D: Governance of schools and teacher management under Education Ordinance of 1952

Figure E: Governance of schools and teacher management after 1954

Figure F: Governance of schools and teacher management after 1967

Figure G: TSC County and Sub-county combined Technical Organizational Structure

Figure H: TSC County Organizational/Administrative Structure

Figure I: TSC Sub-county Organizational/Administrative Structure

Figure J: The administrative structure of institutions of basic education in under the Kenyan legal system

ABBREVIATIONS AND ACRONYMS

ACK	Anglican Church of Kenya
ACWC	African Charter on the Welfare of the Child
AEO	Area Education Officers
AIDs	Acquired Immune Deficiency Syndrome.
BoM	Board of Management
BoG	Board of Governors
CDE	County Director of Education
CEB	County Education Board
CEO	Chief Executive Officer
CEC	County Executive Committee Member
CQASO	County Quality Assurance and Standards Officer
CRC	Convention on the Rights of the Child
CS	Cabinet Secretary
CSO	Curriculum Support Officers
DEB	District Education Board
DEO	District Education Officers
DG	Director General
ECDE	Early Childhood Development Education Centres
HIV	Human Immunodeficiency Virus
KNUT	Kenya National Union of Teachers
MoE	Ministry of Education
NEB	National Education Board
NLC	National Land Commission
PDE	Provincial Director of Education
SCDE	Sub County Director of Education
TSC	Teachers Service Commission
UNDP	United Nations Development Programme

TABLE OF CONTENTS

DECLARATION	i
DEDICATION.....	ii
ACKNOWLEDGEMENTS.....	iii
TABLE OF CASES	v
TABLE OF KENYA LEGISLATION.....	vi
STATUTES	vi
REGULATIONS	vi
TABLE OF INTERNATIONAL CONVENTIONS.....	vii
TABLE OF REGIONAL CONVENTIONS	vii
TABLE OF FIGURES	viii
ABBREVIATIONS AND ACRONYMS	ix
TABLE OF CONTENTS	x
ABSTRACT	xv
CHAPTER ONE	1
INTRODUCTION	1
1.0 Introduction.....	1
1.1.1 Background to the problem.....	2
1.2 Statement Problem	3
1.3 Hypothesis	4
1.4 Justification of the Study	4
1.5 Statement of Objective	5
1.5.1 Specific Objectives.....	5
1.6 Research Questions	5
1.7 Theoretical and Conceptual Framework.....	6
1.7.2 Sociological Jurisprudence and the Sociology of Law.....	6
1.7.3 Critical Legal Studies	7
1.7.4 Conceptual Framework.....	8
1.7.4.1 Governance and Management.....	8
1.8 Research Methodology	10
1.9 Literature Review	11
1.9.1 School Based Teacher Management, Decentralization and Emerging Issues	11
1.9.3 Decentralization of Teacher Management and Emerging Issues.....	13

1.9.4 Role of Teachers Service Commissions under Constitution of Kenya 2010.....	13
1.9.5 Management and Evaluation of Schools	14
1.9.7 Education Management	15
1.9.8 Decentralization and Privatization in Education.....	16
1.9.9 Relationship between Constitutional Commissions and other Agencies	16
1.10 Chapter Breakdown.....	17
CHAPTER TWO	18
HISTORICAL BACKGROUND AND CONTEXT	18
2.0 Introduction.....	18
2.1 Pre Colonial Period	18
2.3 Colonial Period	19
2.3.1 1835 - 1924.....	19
2.3.2 Education Ordinance of 1924	20
2.3.3 Education Ordinance of 1931	21
2.3.4 District Education Boards Ordinance of 1934.....	23
2.3.5 Education Ordinance 1952.....	25
2.4 Post-Independence Period	29
2.5 Post 2010 Period	35
2.5.1 Role of Teachers Union in Management of Teachers.....	37
2.6 Conclusion	38
CHAPTER THREE	39
POLICY, LEGISLATIVE AND INSTITUTIONAL FRAMEWORK	40
GOVERNING TEACHER MANAGEMENT AND GOVERNANCE	40
OF PUBLIC SCHOOLS IN KENYA	40
3.0 Introduction.....	40
3.1 International Legal Framework.....	40
3.1.1 Convention on the Rights of a Child	41
3.1.2 United Nations Convention on the Rights of Persons with Disabilities, 2006.....	41
3.2 Regional Legal Framework	42
3.2.1 African Charter on Rights and Welfare of the Child	42
3.3 Policy Framework	42
3.3.1 Education Policy Evolution and Implementation in Kenya	42
3.3.3 Sessional Paper No. 14 of 2012.	43
3.3.4 Sector Policy for Learners and Trainees with Disabilities 2018.....	44

3.5 Domestic Legal Framework.....	45
3.5.1 Constitution of Kenya 2010.....	45
3.6 Teachers Service Commission Act No. 20 of 2012	48
3.7 Teachers Service Commission Code of Regulations for Teachers, LN No. 196 of 2015.....	50
3.8 Teachers Service Commission (Code of Conduct and Ethics of Teachers)	50
Regulations, LN No. 162 of 2015.....	50
3.8.1 Institutional Framework for Teacher Management.....	51
3.8.2 The Secretariat	51
3.8.3 TSC County Office.....	52
3.8.4 TSC Sub-County Offices.....	54
3.8.5 Curriculum Support Offices.....	55
3.8.6 Boards of Management.....	56
3.8.7 Heads of Institutions as TSC Agents.....	57
3.9 Governance of Public Schools in Kenya	58
3.9.1 Basic Education Act, No. 14 of 2013.....	58
3.9.1.3 Role of Sponsor under the Basic Education Act.....	59
3.9.1.4 Responsibility of Government under the Basic Education Act	61
3.9.1.5 Children Act, No. 8 of 2001.....	62
3.9.1.6 Basic Education Regulations, LN No. 39 of 2015	62
3.10 Institutional Framework for Management of Public Schools.	63
3.10.1 Ministry of Education.	63
3.10.2 National Education Board.....	64
3.10.3 Education Standards and Quality Assurance Council.....	65
3.10.4 County Education Boards.....	65
3.10.5 County Director of Education	66
3.10.6 Boards of Management.....	66
3.10.7 Heads of Institutions as Agents of the Ministry in Governance of Schools.....	67
3.11 Conclusion	69
CHAPTER FOUR.....	70
FIELD STUDY OF KAKAMEGA COUNTY RELATING TO TENSIONS BETWEEN	
TEACHERS SERVICE COMMISSION AND MINISTRY OF EDUCATION.....	70
4.0 Introduction.....	70
4.1 Research Design.....	70
4.2 Data Collection	71

4.3 Data Analysis	72
4.4 Role of Teachers Service Commission.....	72
4.4.1 Tension between TSC and MOE.....	73
4.4.1.1 Boards of Management.....	74
4.4.1.2 Management of funds	75
4.4.2 Relationship between Ministry of Education and Teachers Service Commission.	75
4.5 Role of Ministry of Education	76
4.5.1 Quality assurance and maintenance of standards.....	76
4.5.2 Rivalry between TSC and Ministry.....	77
4.5.3 Independence of Commissions	78
4.5.4 Capacity Building.....	79
4.5.5 Governance of Schools.....	79
4.6 Representation from the Sponsor	80
4.6.1 Appointment of Principals and Head Teachers.....	80
4.6.2 School Land Title Deeds	82
4.6.3 Religious Practices	83
4.7 Responses from Board of Management	83
4.7.1 Role of Boards in teacher management.....	84
4.7.2 Roles of Boards in governance of schools.....	85
4.8 Relationship between Boards of Management and Principals.....	85
4.9 Responses from Heads of Institutions	87
4.9.1 Heads as lead educators and administrators	87
4.9.2 Governance of Schools.....	88
4.10 Boards of Management Teachers.....	89
4.11 Findings	90
4.12 Conclusion	91
CHAPTER FIVE.....	93
CONCLUSION AND RECOMMENDATIONS	93
5.0 Conclusion	93
5.2 Key Areas of Tension between TSC and MOE	94
5.2.1 Teacher Management	94
5.2.2 Governance of Schools.....	95
5.2.3 Sponsors.....	96
5.3 Recommendations	97

5.3.1 Teachers Service Commission Act, 2012.....	97
5.3.2 Basic Education Act 2013	97
5.3.3 Basic Education Regulations 2015.....	98
5.3.4 Composition of Teachers Service Commission.....	98
BIBLIOGRAPHY	100
APPENDIX 1	1

ABSTRACT

The Constitution of Kenya 2010 establishes the Teachers Service Commission (TSC) and assigns it all teacher related functions. The Teachers Service Commission Act, 2012, which was enacted to give effect to Article 237 of the Constitution of Kenya, 2010 fails to create a legal framework of engagement between the Commission and the Ministry of Education (MoE) in teacher management and governance of schools hence occasioning tensions between TSC and MoE. The tensions existing between TSC and MoE in discharge of their roles are premised on the fact that teacher management has historically been a function of the Ministry of Education. Through archival, case study and historical research methodologies, this study examines the historical relationship between TSC and MoE, reviews the existing legal framework with the view of identifying gaps apparent and using a case study of Kakamega County, identifies tensions between TSC and MoE as well as administrative challenges facing heads of public schools. This project is divided into five chapters. The first chapter identifies the problem, states the objective of study, outlines research questions, discusses theories used, reviews literature and identifies the gap in existing literature. Chapter two gives a historical background of teacher management and governance of public schools. Chapter three critically examines the legal and institutional framework while chapter four entails a case study of Kakamega County in relation to tensions existing between TSC and MoE. The study concludes with some reflections and recommendations. The study establishes that until 2010, teacher related functions were performed by TSC under the patronage of Minister for Education. TSC existed as a semi-autonomous unit within the Ministry of Education. After 2010, TSC was elevated to a Constitutional Commission and vested with teacher related functions. However, the enabling Acts and regulations fail to provide framework of engagement between TSC and MoE on teacher management and

governance of schools. This omission has brought about tensions between the Ministry and the Commission. The areas of tension include; deployment and discipline of heads of institutions of basic Education, Role of Boards of management in governance of schools and Role of Sponsors in teacher management and governance of schools. To harmonize the relationship between TSC and MoE, laws need to be interpreted in context, culture of mutual co-operation has to be established, and laws have to be reviewed to address the problem of duplication of roles and structures.

CHAPTER ONE

INTRODUCTION

1.0 Introduction

This study critically interrogates the role of the Teachers Service Commission (TSC) and the Ministry of Education (MoE) in teacher management and governance of public schools under the Kenya Legal system. It argues that whereas the Constitution of Kenya 2010 establishes TSC and assigns it roles to register, appoint, deploy, transfer, promote and discipline teachers, the Teachers Service Commission Act, 2012 fails to outline the role of the Ministry of Education in teacher management, thus occasioning power struggles between TSC and MoE. The power struggles exist because MoE has historically performed the role of teacher management.

Before the promulgation of the Constitution of Kenya 2010, TSC existed as a creation of Statute¹ and was answerable to the Ministry of Education. The Commission implemented the Minister's directives regarding teacher management. Article 237 of the Constitution of Kenya 2010 elevated TSC to an independent Constitutional Commission and vested in it the exclusive powers over teacher management. This left the Ministry with policy roles, including the development of the curriculum and governance of schools but with no power over teachers who are the curriculum implementers and the head teachers who play a critical role in governance of schools.

In discharge of their dual responsibilities both as employees of an independent Commission and as agents of the Ministry of Education in curriculum implementation and school management, heads of schools have often found themselves in a legal dilemma. What should happen when there is a conflict of roles between TSC and the Ministry of Education? Whose decision should take precedence?

¹ Education Act, Chapter 211 of Laws of Kenya (Repealed)

1.1.1 Background to the problem

The Ministry of Education has the roles of developing the national education policy, including designing the curriculum as well as governance of schools. Governance includes maintenance of the school infrastructure, prudent administration of funds and student management.

Once the curriculum has been developed, the Ministry hands it over to TSC for implementation. TSC thereafter recruits registered teachers to implement the curriculum and designates one person, the head teacher as the lead educator, who in addition to being in charge of teacher management at the school level, also exercises authority over the Ministry assets, a designation given to him by the Cabinet Secretary. Whereas the ministry delegates infrastructural management, management of students and accounting roles to the heads of institutions, it has no disciplinary powers over them. The lead educator remains answerable to TSC.

The Ministry of Education has appointed County Directors of Education (CDE) and Sub County Directors of Education (SCDE) to oversee the implementation of its policies at the county and sub county levels respectively. TSC has equally appointed its own set of County Directors to carry out teacher related functions at the county level while at the Sub county level they have persons equally referred to as Sub County Directors.

In its advisory opinion of September 2014 to the Attorney General, titled; ‘Legal Interpretation and Conflicting Functions of the MoE and its agencies’, the Commission on the implementation of the Constitution (now defunct), stated that section 35 (1) of the Teachers Service Commission Act, 2012 is unconstitutional on the grounds that teacher regulation is a matter of policy which should be addressed by the Ministry of Education. This seemed to imply that management of teachers under the Kenyan legal system is, in practice, a shared function between Teachers Service Commission and the Ministry of Education. Whereas the Ministry welcomed this advisory

opinion, the commission saw it as an intended encroachment by the Ministry on its constitutionally ordained mandate.

In June 2014, the Ministry of Education drafted the Basic Education Regulations that sought to place head teachers and principals under the management of the Ministry of Education. These proposals were rejected by both KNUT and KUPPET, terming them as a contravention of Article 237 of the Constitution of Kenya 2010.

On the 8th of April 2015, the Cabinet Secretary for Education gazetted the Basic Education Regulations 2015 to operationalize the Basic Education Act 2013.² The Regulations deem the heads of institutions to be the accounting officers of their respective schools, an authority delegated to them by the Cabinet Secretary. Stakeholders in the Education sector, among them the Kenya National Union of Teachers, have termed this provision as an attempt to take back the Constitutional powers of the commission through delegated legislation.

In July 2016, the High Court dismissed a petition by Elimu Yetu Coalition, a registered Trust and Kenyan Education Coalition which had moved to court to have the powers to appoint heads of institutions moved from the Commission to the Ministry of Education.³

This apparent conflict of roles calls for a critical analysis of tensions in teacher management and governance of public schools under Kenya's post 2010 legal system.

1.2 Statement Problem

Although the Constitution of Kenya 2010 establishes the Teachers Service Commission (TSC) to oversee registration of trained teachers, appointment, deployment, transfer, promotion and

² Legal Notice No.39 of 2015, Printed and Printed and Published by the Government Printer.

³ Elimu Yetu Coalition vs. Teachers Service Commission & 2 Others, High Court Petition No. 131 of 2015 at Nairobi (Unreported).

discipline of teachers, nevertheless, the Teachers Service Commission Act, 2012 fails to provide for the role of Ministry of Education (MoE) in teacher management therefore occasioning tensions between TSC and MOE in discharge of their functions. This omission has brought about duplication of roles between the two entities. In addition, the omissions create a perception that MOE has little role to play in teacher management.

1.3 Hypothesis

This study is premised on a hypothesis that existing tensions between the Teachers Service Commission and the Ministry of Education are as a result of lack of harmony between the Basic Education Act, 2013 and the Teachers Service Commission Act, 2012 in relation to teacher management and governance of public schools.

1.4 Justification of the Study

Having reviewed the existing literature on the role and functions of TSC and the Ministry of Education prior to, and after coming into force of new Constitution, the study established that very little has been written about the conflict of laws regulating the functioning of the two entities in the discharge of their duties. This study seeks to inform policy makers and legislators on key reform issues in teacher management and governance of public schools in Kenya. This study intervenes in a broader discussion around the conflicts between constitutional commissions and other constitutional organs. Previously, it has been widely held that MoE plays a role in teacher management. However, the study seeks to disprove this notion. The study is also justified on the premise that while several scholars have discussed the tensions between Constitutional Commissions and government agencies, scanty literature exists on the relationship between TSC and MoE.

1.5 Statement of Objective

This study examines the tensions between Teachers Service Commission and the Ministry of Education in teacher management and governance of schools under the Kenya's post 2010 legal system.

1.5.1 Specific Objectives

1. Review the history of teacher management and governance of public schools in Kenya with the view of understanding the root cause of existing tensions between TSC and MoE.
2. Examine the gaps in existing legal and policy framework on teacher management and governance of public schools in Kenya.
3. Identify and examine tensions existing between Ministry of Education and Teachers Service Commission in teacher management and governance of public schools in Kenya using a case study of Kakamega County.
4. Make recommendations aimed at harmonizing the relationship between TSC and MoE in discharge of their functions.

1.6 Research Questions

This study seeks to answer the following questions;

1. What is the history of teacher management and governance of public schools in Kenya?
When did tensions between TSC and MoE begin to manifest and why?
2. What are the gaps in relevant laws and policies governing teacher management and governance of public institutions of basic learning in Kenya?

3. What are the tensions existing between Ministry of Education and Teachers Service Commission in teacher management and governance of public schools in Kakamega County?
4. What should be done to harmonise the relationship between TSC and the Ministry of Education in discharge of their functions?

1.7 Theoretical and Conceptual Framework

This study relies on sociological jurisprudence and critical legal theories to explore the research questions. These theories help us to understand the strong connection between law and politics and law in action that produce power struggles and tensions in government institutions. By connecting law with politics, we find that even when the Constitution assigns teacher management functions to TSC, it is difficult to exclude the Ministry of Education from playing an oversight role over teachers as policy implementers.

1.7.2 Sociological Jurisprudence and the Sociology of Law

This study employs sociological jurisprudence. Sociology of law popularizes the law as a tool for social ordering. Drawing from Malinowskian functionalist paradigm, the theory proposes that law should be responsive to culture, religion, economics, history, art, and technological advancement in society. The foremost advocate of sociological jurisprudence is Roscoe Pound.⁴ In his seminal treatise on “Scope and Purpose of Sociological Jurisprudence”, Pound dismisses pedantic adherence to black letter law. He asserts that law is alive and constantly communicates to be of service to society. Law is not sacred or mysterious. The theory allows us to interrogate legal principles and doctrines freely regardless of our disciplinary backgrounds as: historians, literary scholars, economists, or sociologists. As James Gardner⁵ aptly points out, sociology of law

⁴ Roscoe Pound, *The Scope and Purpose of Sociological Jurisprudence III*, (25 HARV. L. REV.489 1912).

⁵ James A. Gardner, *The Sociological Jurisprudence of Roscoe Pound* (1961),

democratizes legal reasoning since knowledge of the law is no longer a necessary prerequisite to legislation. Most important, the theory gives credence to cultural relativism as opposed to universalism often times employed to lend credence to Western perspectives. Rejecting the idea that law can be studied as a science, Holmes emphatically rebuts Langdell's argument that legal systems are based on the rules of logic. In his seminal text, *The Path of the Law*, Holmes disassociates law from morality and logic and focuses on policy.⁶ He therefore defines the law as a prediction of what the courts would do in a particular situation based on a "bad man" theory of justice.⁷ I concur with Holmes that a bad man in society will always want to know only what the material consequences of his or her conduct will be regardless of whether it is motivated by morality or conscience. Malinowski, Dworkin and Holmes highlight the instrumentality of law in social engineering. Law is not detached from society. It is the glue that holds society together. Law cannot therefore be studied outside the society that creates and sustains it.

This project uses this theory to demonstrate that there exists law on paper and the law in action in so far as teacher management and governance of public schools is concerned in Kenya. The regime of laws governing Education sector should be viewed as operating in a living society. The interpretation of such laws should conform to the needs of the society.

1.7.3 Critical Legal Studies

The main proponents of this theory are Oliver Wendell Holmes, Duncan Kennedy and Robert Hale. The central argument they make is that law is to be evaluated from political context. They posit that to understand the law one needs to first understand political theories surrounding it.

⁶ Oliver Wendell Holmes *ibid.* 9

⁷ Oliver Wendell Holmes *ibid.* 28

This theory helps us understand the existence of tensions between TSC and MOE as failure to appreciate the politics that surround policy formulation and implementation within the Kenya education system. Critics of this school argue that law and politics are to be viewed separately. Hans Kelsen argues that an attempt should be made to understand law devoid of other impurities.⁸

TSC and MoE cannot discharge their roles without considering the prevailing political environment in which they are set. The Ministry of Education is a political office, whose occupant relies on Executive order by the president to know his role. As a creature of a political process, the Ministry of Education finds it a challenge to address the societal demands and at the same time observe the boundaries set by law. The Ministry therefore formulates policy aimed at addressing emerging issues relating to governance of schools and teacher management. Whereas the society expects the Cabinet Secretary for Education to ensure stability and performance in schools by supervising lazy and errand teachers, the law vests in TSC the powers of teacher supervision.

1.7.4 Conceptual Framework

This section provides the meaning and perspective of the concept of governance and management the study relies on.

1.7.4.1 Governance and Management

International agencies such as World Bank and UNDP have defined governance as the structures and processes that are designed to guarantee accountability, transparency and responsiveness.⁹

Kjaer defines governance as exercise of power or authority by political leaders for advancement of society's interest.¹⁰

⁸ Freeman M.D.A, *Introduction to Jurisprudence*, (8th Edition, Sweet & Maxwell 2001).

⁹ Retrieved from;www.unesco.org/new/en/education/theories/strengthening/education-systems/quality-framework/technicalities accorded on 16.08.2018 <Accessed at 1751hrs>.

¹⁰ Anne Mette Kjaer, *Governance* (Cambridge Polity Press, 2004) 3.

Mann defines governance as the ability of government to make and enforce rules, regardless of the process that brings that government to power.¹¹ The essence of governance in Education sector is to administer resources allocated to public institutions of basic learning and manage the human resource other than the teaching staff within public schools.

This study relies on the concept of governance contemplated by the Constitution of Kenya 2010 which provides for national values and principles of governance that bind all state organs and public officers wherever they make or implement public policy decisions.¹² The national values and principles of governance include good governance, integrity and transparency.¹³ Presidential Taskforces on Parastatals Reforms report underscored the role of Board of Management in institutionalising the culture of good corporate governance in state corporations and public entities.¹⁴

The study understands good governance to mean prudent, accountable and transparent discharge of public authority.

Olum defines management as the art of achieving goals through people.¹⁵ He argues that management involves designing and maintenance of a conducive environment capable of maximising outputs.¹⁶ Taylor defines management as the art of knowing what to do, when to do and seeing to it that it is done in the best way.¹⁷

¹¹ Michael Mann; 'The Autonomous Powers of the state: H S Origins, mechanisms and results', *European Journal of Sociology* 25(2), (1984)185 – 213.

¹² The Constitution of Kenya, 2010, Article 10.

¹³ Ibid.

¹⁴ Mwongozo; The Code of Governance for State Corporations issued by H.E the President on 15th March, 2015 vide the Executive Order No. 7 instructing all Boards to implement its provisions

¹⁵ Olum Yasin, *Modern Management Theories and Practices*, presented at the 15th East African Central Banking Course on 12th July 2004, at Kenya School of Monetary Studies.

¹⁶ Ibid

¹⁷ Hakan Turan, Taylor's "Scientific Management Principles": Contemplating issues in personal selection period. *Journal of Economics, Business and Management*, Vol. 3 No. 11, November, 2015

Koontz and Wehrich expand the concept of Management to mean assignment of roles to persons in positions of leadership and execution of those roles as well as effectiveness and efficiency of such persons.¹⁸

This project understands management to mean the ability of persons in authority to discharge their functions individually and objectively with their subordinates with the primary motive of maximizing the output.

1.8 Research Methodology

This study relied on desk-based study, field study and archival research methodologies. Desk-based study utilised primary and secondary sources. The primary sources utilised include domestic, regional and international instruments which include Constitution of Kenya 2010, Basic Education Act 2013, Teachers Service Commission Act 2012, Basic Education Regulations 2015, TSC Code of Regulations and Conduct for Teachers, The Convention on Rights of the Child, African Charter on the Rights and Welfare of the Child and the African Charter on Human and Peoples Rights, 1981. The study used field study methodology in order to establish existing tensions between TSC and MoE, their causes and suggested remedial measures. Field study entailed interviews of heads of public schools, drawn from both primary and secondary schools, Sub County Directors (Drawn from both the Ministry of Education and TSC), chairpersons of Boards of Management, sponsors and County Directors (From both the Ministry and TSC). The choice of heads of schools, as interviewees, was guided by convenience sampling under the Non-probability sampling method because of their schedules. They were selected based on availability. The choice of county directors of Education and Sub-county Directors of Education was informed

¹⁸ Koontz Harold, The Management Theory, Harvard Business Review, April, 2004

by purposive sampling procedure purposely because they hold the information required. The study used interview schedules

The field study is undertaken in Kakamega County in Western Kenya. The choice of Kakamega was informed by the fact that in terms of population it is the second largest county in Kenya. This expansive and cosmopolitan nature is likely to reflect the feeling in most counties in the Republic.

1.9 Literature Review

This study reviews different sets of literature relating to teacher management and governance of schools. Themes discussed under this section include School based teacher management, placement of teachers, decentralisation of teacher management, role of Teachers Service Commission under the Constitution of Kenya, management and evaluation of Schools, roles of teachers and learners, education management, decentralisation and privatisation in education and relationship between Constitutional Commissions and other Agencies.

1.9.1 School Based Teacher Management, Decentralization and Emerging Issues

Mugambi and Ochieng¹⁹ underscore the effectiveness of school based teacher management in improving the standards of education and advocates for a departure from a centralised teacher management system to a school based teacher management. They argue that centralisation of TSC makes it ineffective in the discharge of its roles as forty-seven counties cannot effectively be run from one central office in Nairobi.

¹⁹ Mugambi M, &Ochieng R, “Repositioning School Based Teacher Management in Kenya: Global Practices and Approaches,” (2016) International Journal of Education and Practice.

Heads of Schools have to balance between professional management of individual teachers and their administrative roles of running the schools.²⁰ They view schools as organisations where the head teachers are managers while the heads of departments are line managers.

Mugambi and Ochieng²¹ argue that although TSC is mandated by law, to recruit and deploy teachers in public schools, head teachers have a role in ensuring sufficient staffing of their schools. They fault the current system of having a bias towards maintaining teaching standards through discipline and enforcing the code of conduct at the expense of actual delivery.

On the other hand Piotr & Jacek²² argue that new public management and processes of education have increased school autonomy. They further examine with approval the impact of new management systems in education in different countries across the globe observing that departure from a centralised to a decentralised system guarantees the autonomy of a school as an organisation and increases the efficiency of public organisations.

Ojwang²³ argues that decentralisation has brought TSC services closer to the users. He examines the reform initiatives that TSC has undertaken in order to improve quality in discharge of its roles. Such initiative is the decentralisation of teacher placement to the district and school level. TSC recruits on the basis of demands and availability of vacancies. To these end, declaration of vacancies is done at the commission whereas applications are made to individual schools where vacancies have been declared.

²⁰ Ibid.

²¹ Supra note 22

²² Piotr&Jacek, “New Public Management and Processes of Education” (Management, Knowledge and Learning International Conference; Potoroz, Slovenia, 25-27 June 2014).

²³Ojwang’ M. A, “Effects of the Restructuring of Teacher Placement on Teacher and Gender Distribution in Public Secondary Schools in Nakuru County; Kenya.” Baraton Interdisciplinary Research Journal (2016) page 83.

Ojwang²⁴ observes that the policy on decentralisation is being implemented by school's Boards of Management using guidelines revised and documented every year before recruitment exercises.

1.9.3 Decentralization of Teacher Management and Emerging Issues

Gaynor²⁵ argues that in most centralised systems, teachers are employed by government and subjected to regulations and hierarchical management systems. She identifies the models of decentralised teacher management to include; administrative model, alternative model and the grassroots model.

Owuor and Odera²⁶ review the TSC Act under the Constitution of Kenya 2010 and the emerging issues in teacher management. The emerging issues include teacher shortage, professionalization of the teaching service, promotion, performance and conduct of teachers, the industrial unrests and the management of H.I.V and A.I.D.S. They further argue that, following the promulgation of the Constitution of Kenya 2010 and the enactment of TSC Act, the commission has a mandate to perform all teacher related functions.

Even though these authors discuss decentralisation of teacher management and emerging issues in depth, they nonetheless fail to identify the root causes of challenges facing teacher management in the contemporary society.

1.9.4 Role of Teachers Service Commissions under Constitution of Kenya 2010

Lumumba and Franceschi²⁷ trace the history of teacher management back to colonial days when teachers were under the management of various bodies. The missionaries and the colonial

²⁴ Ibid.

²⁵ Cathy Gaynor, "Directions in Development; Decentralization of Education, Teacher Management", World Bank, 2016.

²⁶ Owuor D & Odera B, "Teacher Management; Emerging Issues in Kenya", European Journal of Educational Sciences, (2017) Vol. 4.

²⁷ Lumumba PLO & Franceschi L, *The Constitution of Kenya, 2010: An Introductory Commentary*, (Strathmore University Press 2014) 611.

government employed primary school teachers whereas the African Teachers Service and Colonial Government employed both African and European secondary school teachers. According to the duo, KNUT was instrumental in the formation of TSC, a central body that would manage teachers' affairs, leading to enactment of TSC Act in 1967.²⁸ They observe that TSC largely worked as a department at the Ministry of Education until 2010 when the Commission became an independent body with exclusive mandate over teacher management.

Sihanya²⁹ argues that TSC is an independent constitutional commission established under the Constitution of Kenya 2010 to be in charge of the human resource in the education sector. He decries low pay and protracted legal battle over teachers' pay between the Government and teachers, dating back to 1992, as being a major setback to the commission.

Sihanya, Lumumba and Franceschi fail to locate the point of convergence between TSC and M.o.E in discharge of their duties.

1.9.5 Management and Evaluation of Schools

Sushila argues that, the public nature of Kenyan schools is such that they are to be governed by a central body such as the Ministry of Education which outlines the principles underlying the education system in the country and proceeds to set up schools and employs the personnel to oversee these institutions.³⁰ Sushila fails to distinguish the managerial roles and the teaching roles of those employed to run the schools. For effective school management, Bakhda argues that

²⁸ Teachers Service Commission Act Cap 212.

²⁹ Sihanya B, "Constitutional Commissions in Kenya: Experiences, Challenges and Lessons" Conference on State Implementation of the Constitution since 2010, Laico Regency, November 20, (2013).

³⁰Sushila Bakhda, *Management and Evaluation of Schools*, (Oxford University Press 2004).

appropriate members of staff should be employed, there should be established a management hierarchy of authority and there should exist a joint effort and coordination among stakeholders.³¹

Wright explores teaching and learning as social activities.³² He summarises interpersonal factors influencing the role relations between teachers and learners to include status and position, attitude and beliefs, personality and motivation.

1.9.7 Education Management

Margaret posits that the effort to increase quality in education is a continuous process.³³ She cites the external pressure as playing an important role in advocating for quality education. The external pressure includes educational issues which are concerned with performance of schools, and colleges. This pressure comes from the government, the inspectorate and the public at large.³⁴ Additionally, there are political issues which are concerned with reducing public spending as a proportion of gross domestic product and the demands of education as well as the economic arguments which are concerned with the link between educational spending and economic success. She further observes that legislative changes bring about an increased autonomy for schools and colleges and as such makes requirements making them more accountable for their monetary and governance decisions.³⁵ The legislative changes are more concerned with funding which is proportional to student numbers, prescribed national curriculum and testing arrangements as well as publication of performance data on test and examination results. Nonetheless, management does not authoritatively allocate the role of quality maintenance in schools. Quality maintenance

³¹ Ibid.

³² Tony Wright, *Roles of Teachers and Learners*, (Oxford University Press 1987).

³³ Margaret P, et al (eds), *Educational management : Strategy, Quality and Resources*

³⁴ Ibid.

³⁵ Supra note 4.

and standards assurance forms part of contested assignments between TSC and M.o.E in the current education system in Kenya.

1.9.8 Decentralization and Privatization in Education

Zajda³⁶ discusses government involvement in education. He argues for the centralisation of certain functions including provision of mass education. He acknowledges that the process of decentralisation and privatisation has, to an extent, been influenced by external factors such as the Bretton wood institutions. He observes that the attack on government monopoly over schools is based on accountability, efficiency and quality. Zajda however fails to disclose the means to be employed by state to achieve its role in shaping and controlling education.

1.9.9 Relationship between Constitutional Commissions and other Agencies

Sihanya argues that the Ministry of Lands has occasionally undermined the constitutional status of the National Land Commission (NLC).³⁷ The Ministry of Lands has often purported to perform functions that are constitutionally designed to be performed by NLC.

Review of literature reveals that there are limited number of studies in Kenya on teacher management and governance of public institutions of basic learning in the post-2010 period. This could be attributed to the fact that prior to the promulgation of the Constitution of Kenya 2010, teacher management and governance of public schools was a prerogative of the Minister and the possibility of a conflict was remote. Whereas there exists literature on teacher education and management in the post 2010 period, there is little mention of the tensions existing between TSC and MoE. This study therefore seeks to fill the existing gap by critically examining the role of TSC and MoE under the new constitutional dispensation.

³⁶ Joseph Zajda(ed), Decentralization and Privatization in Education: The role of the state, 2006.

³⁷ Sihanya B, "Constitutional Commissions in Kenya: Experiences, Challenges and Lessons" Conference on State Implementation of the Constitution since 2010, Laico Regency, November 20, (2013).

1.10 Chapter Breakdown

The study is comprised of five chapters.

Chapter One is an introductory chapter consisting of the statement of the problem, hypothesis, objectives of the study, research questions, theoretical and conceptual framework, justification of the study and literature review.

Chapter Two reviews the history of the education system in Kenya and the roles played by various stakeholders from the pre-colonial period to the post-2010 period with the view of locating the root cause of tensions existing between TSC and MoE.

Chapter Three analyses the existing policy, legal and institutional framework with regard to teacher management and governance in schools with the view of identifying gaps responsible for existing tensions between TSC and MoE.

Chapter Four provides a field study of Kakamega County relating to tensions between TSC and MoE.

Chapter Five provides the conclusion and recommendations of the study.

CHAPTER TWO

HISTORICAL BACKGROUND AND CONTEXT

2.0 Introduction

This Chapter situates teacher management and governance of public schools in Kenya within a historical background. It is divided into four main parts. The first part discusses the concept of teacher management and governance of schools in Precolonial period. The second part interrogates government involvement in Education during the colonial period. This part examines the legislative framework and key events that impact on teacher management and governance of public schools. Part three looks at teacher management and governance of schools in post-colonial period. This entails a study of the recommendations of various commissions and sessional papers as well as the post-independent legislative framework. The last part examines teacher management and governance of schools under the Constitution of Kenya 2010.

Historical background traces and discusses the evolution of teacher management and governance of schools. The chapter aims at proving the hypotheses that teacher management has historically been performed by MoE.

2.1 Pre Colonial Period

Before Kenya become a protectorate of Great Britain, provision of education was largely managed by individual communities through informal processes.³⁸ Teachers had no formal training and thus passed the skills through apprenticeship.³⁹ There were no schools or formal structures. The missionaries who had already established themselves in Kenya by nineteenth century served as critical actors in the conversion of Africans to Christianity. During this period, teacher

³⁸ Jones T, *Education in East Africa, A study of East, Central and South Africa by Second African Education Commission Under the Auspices of the Phelps- Stokes Fund, in cooperation with the International Education Board*,(Edinburg House Press, London).

³⁹ Ibid.

management and governance of informal institutions of learning was a function of individual communities.

2.3 Colonial Period

2.3.1 1835 - 1924

In the year 1895, Great Britain through Imperial British East African Company took over Kenya and sought to provide schools for the children of white settlers.⁴⁰ The colonial Government preferred leaving education of Africans in the hands of missionaries.⁴¹ The purpose of missionary education at its inception was to train catechists and persons who would train Africans on practical skills.⁴² Since missionaries had pre-conceived notions about African culture, teacher training was biased towards creation of a teaching force that would advance missionary interests.⁴³

In 1911, management of Education took a new turn when colonial Government established an Education department within its structures of governance. The department was to coordinate provision of education through missionary agencies.⁴⁴ The creation of the department and subsequent appointment of the first Director of Education saw government subsidize mission education. In addition, formal government involvement in education gave rise to growth of institutions called Government schools. The Government schools were run by education department as missionaries ran their own schools.

In 1918, the Director of Education appointed a commission which urged government to give greater support to voluntary agencies and on the self-appointed school committees operating on

⁴⁰ *The 1895 East African Protectorate, Evidence of Education Commission*, (Nairobi: The Swift Press, 1919) 185.

⁴¹ *Ibid.*

⁴² Roland Oliver, *The Missionary Factor in East Africa*, (London, Longman's Green 1952) 213.

⁴³ *Ibid.*

⁴⁴ *The 1895 East African Protectorate, Evidence of Education Commission*, (Nairobi: The Swift Press, 1919).

non-racial lines. Both government and missionaries realised that common interests on matters education would best be served through cooperation.

Mission schools were supervised by missionaries. The Jesse report⁴⁵ commended missionaries for their effective and wise ways of managing village schools. The missionaries hired and managed village teachers and at times relied on visiting teachers to teach in their schools.⁴⁶

2.3.2 Education Ordinance of 1924

In 1924, the management of schools and teaching force was formalised through the passing of an ordinance to provide for the management of Education throughout the colony and protectorate of Kenya.⁴⁷ The ordinance characterised schools into three.

The First category comprised government schools, which were schools established and maintained by public funds. The second category was made of Assisted or Aided schools which comprised schools whose establishment or maintenance or both was assisted by public funds and the Private schools which comprised of schools that did not receive any form of assistance from public funds.⁴⁸ Missionary schools fell in the category of aided as well as private schools, depending on whether or not they received any assistance from the public funds.

The enactment of the Education ordinance placed the administration of education in the hands of the Director of Education with assistance from the central committees appointed by the Governor to advise on education of various races.⁴⁹ The ordinance sought to divide the colony into school areas and in each area, there was constituted an education committee to help the Director effectively manage education as illustrated in figure A. The ordinance sought to regularise the

⁴⁵ Supra note 40.

⁴⁶ Ibid.

⁴⁷ Education Ordinance Number 17 of 1924.

⁴⁸ Ibid, Section 2.

⁴⁹ Ibid, Section 3.

teaching profession by requiring that the persons employed as teachers in government schools be holders of a certificate of competency or a licence to teach as recognized by government. The same qualifications were imposed on teachers teaching in assisted schools.

Figure A: Governance of schools and teacher management under Education Ordinance of 1924

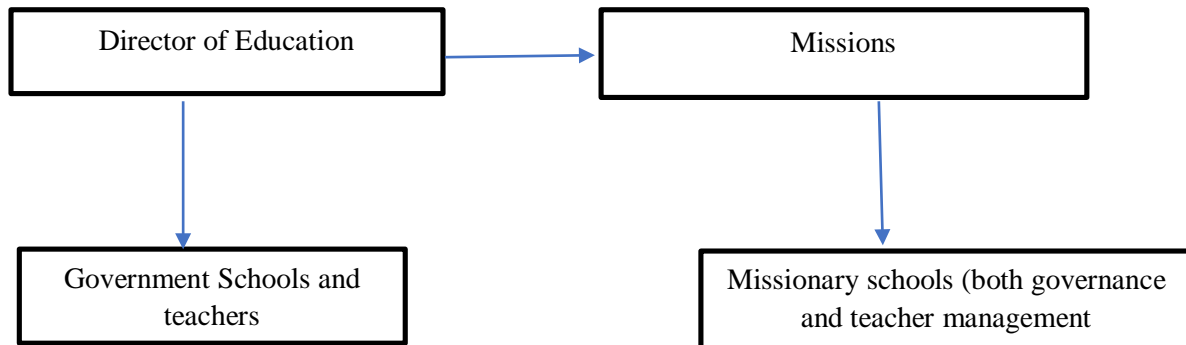

Source: Author.

2.3.3 Education Ordinance of 1931

In 1931, a new ordinance repealed Education ordinance of 1924.⁵⁰ It sought to define a school as an institution in which not less than ten pupils received regular instructions and sought to include any assembly of not less than ten pupils for the purposes of receiving regular instructions.⁵¹ This definition had the effect of excluding institutions where instructions were of religious character as well as those owned and maintained by a religious society for the purposes of training persons for ordained ministry and admission to a religious order.

The ordinance gave the governor exclusive powers to use funds allocated to the education department by the legislative council to establish or make grants in aid for schools and assign funds to managers and tutors for the running of the schools. It further provided for the formation of

⁵⁰ Education Ordinance Number 17 of 1924.

⁵¹ Education Ordinance 1931, Section 2.

Advisory councils to advise the Director of Education with regard to Education matters in the colony.⁵² The functions of the Advisory Councils were to advise the Director of Education on the organisation of schools, the curricular to be adopted, fees to be charged in government schools and offer technical advice on legislation touching on education matters.

The management of schools was a prerogative of individual school committees appointed at the discretion of the Director of Education on request of not less than fifty per cent of parents of such schools. The school committees were to advise the Director regarding the school buildings and premises, to account for grants in aid, consider and decide applications for admission or re-admission of pupils with respect to schools for which the committee was formed.⁵³ In addition, the Ordinance sought to establish school area committees which were chaired by a Provincial Commissioner or a deputy appointed by him.⁵⁴ On the other hand, the school Area Committees were tasked with the responsibility of advising the Director with regard to provision of schools in its area, make recommendations to the Director pertaining the opening, management and closing of public schools, and make proposals to the Director regarding the nature and amount of assistance to be invited from any Local Native Council for the carrying out of education project.⁵⁵ Figure B illustrates the foregoing structure of governance under the 1931 Ordinance.

With regards to the private schools, the Ordinance required that they be registered with the Education Department and a register of teachers employed by such schools be kept.⁵⁶

Appointment of Teachers in all public schools, other than government schools lay with the managers of individual schools.⁵⁷ The managers had powers to dismiss any teacher upon the order

⁵² Ibid, Section 6.

⁵³ Ibid, Section 19.

⁵⁴ Ibid, Section 21.

⁵⁵ Ibid, Section 22.

⁵⁶ Ibid, Section 31.

⁵⁷ Ibid, Section 37.

of the Director of Education, approved by the Governor.⁵⁸ Refusal to comply with such an order had the effect of having grants reduced or withheld.⁵⁹

Figure B: Governance of schools and teacher management under Education Ordinance of 1931

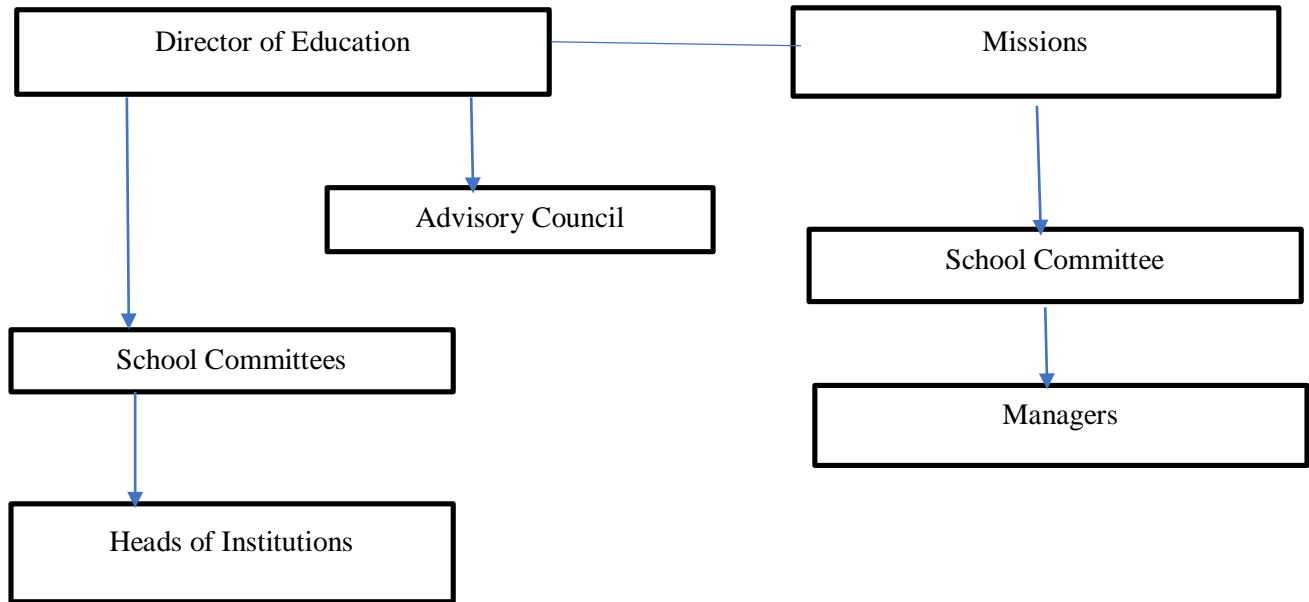

Source: Author

2.3.4 District Education Boards Ordinance of 1934

On the 22nd of August 1934, an Ordinance to make provision for the establishment of District Education Boards in the colony came into force.⁶⁰ The Act gave the Director of Education, in consultation with the Provincial Commissioner Powers to establish District Education Boards which would assist in the development of African Education.⁶¹ The Boards were to be chaired by the District Commissioner, with an Education Officer, appointed by the Director as the Secretary.⁶²

Figure C illustrates the changes brought about by District Education Boards Ordinance of 1934.

⁵⁸ Ibid.

⁵⁹ Supra note 19.

⁶⁰ District Education Boards Ordinance No. XXXVIII of 1934.

⁶¹ District Education Boards Ordinance No. XXXVIII of 1934, Section 3.

⁶² Ibid, Section 4.

The functions of the Board included making recommendations for establishment of elementary and sub-elementary schools, supervision of the working and management of elementary and sub-elementary schools, allocation of grants-in-aid to schools, and general promotion and improvement of schools.⁶³

Figure C: Governance of schools and teachers management under District Education Boards Ordinance of 1934

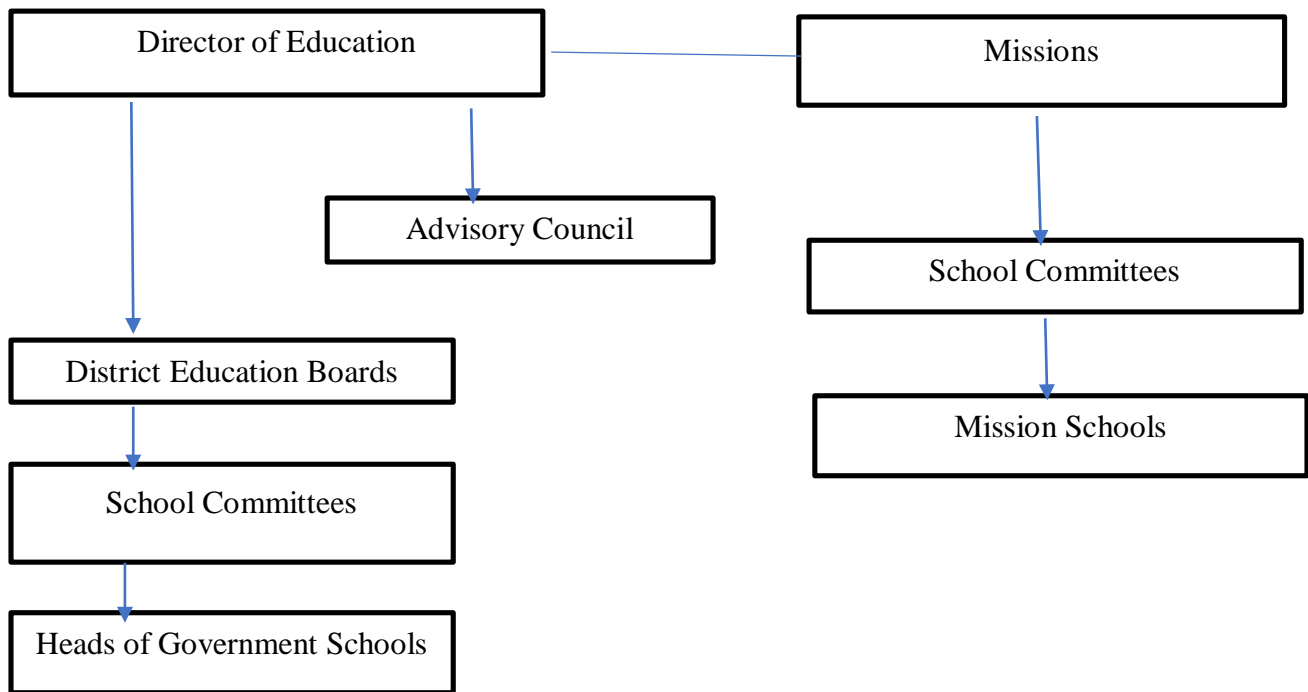

Source: Author

In 1949, the Colonial government appointed a commission chaired by Venerable Arch Deacon L. J. Beecher of Mombasa to examine and report on the entire education system.⁶⁴ The report urged the government to exercise control and strict supervision over the education system. In addition, it recommended that a unified teacher's service be established with a salary scale linked to those of government servants and that superannuation scheme be started. The commission was of the

⁶³ Ibid, Section 7.

⁶⁴ 1949, *Kenya Colony and Protectorate, African Education in Kenya*, (Nairobi: Government Printer, 1949).

view that as a temporary measure, supervisory teams be formed to allow voluntary agencies effectively supervise public schools. It further reaffirmed the role of District Education Boards in the management of schools. To supplement the efforts of D.E.Bs, the Beecher Commission proposed the establishment of Regional Education Boards. R.E.Bs were to partner with D.E.Bs in advising the Director of Education on matters relating to education in the colony.

2.3.5 Education Ordinance 1952

In 1952, the Governor of the colony of Kenya, Sir Evelyn Baring, signed into law an ordinance to reform the law relating to Education in the colony with the advice and consent of the Legislative Council. The new ordinance repealed the Education Ordinance of 1931 and sought to introduce the position of the Member as the general custodian of Education policy in the colony. The member of the Executive Council responsible for Education was equivalent of the present day Cabinet Secretary for Education. The promotion and progressive development of Education shifted from the Director of Education to the Member.⁶⁵ The Member had powers to establish Advisory Councils to advise the Director on matters affecting Education generally.

The ordinance brought new dimensions in the management of public schools in the following ways;

- It established Boards of Governors for Government Schools. The Boards were to manage schools on behalf of Government.
- Provided for the establishment of Boards of Governors for Aided schools where the Director was of the opinion that it was in the interest of the school to have a Board.
- Created School Committees for both government and Aided schools. The committees had no supervisory powers over the teachers and the servants of the school.

⁶⁵ District Education Boards Ordinance No. XXXVIII of 1934, Section 3(1).

The ordinance restructured the D.E.B with the Member directly appointing the chairs whereas the Director retained the powers to appoint the secretary.⁶⁶ The functions of the District Education Boards were the formulation of regulations prescribing powers and duties of the Board in regard to establishment and maintenance of new schools.⁶⁷

In order to give effect to the recommendations in the Beecher report, the Ordinance provided for the establishment of Regional Education Boards.⁶⁸ The R.E.Bs were to advise the Director on the establishment and management of new schools as well as management of any public school which the Director considers should be managed by the Board.⁶⁹ Teaching certificates and licences were to be issued and signed by the Director of Education.⁷⁰ The Director had the right to recall such certificates.⁷¹ Whereas teachers in government schools were appointed by the government, the powers to appoint teachers in any Aided school lay with the manager of such school but every such appointment was to be approved by the Director.⁷² Figure D illustrates the structure of governance under the Ordinance.

The ordinance defined and prescribed punishment to offences relating to Teaching Profession. The offences included teaching without a licence, employing teachers without a valid teaching licence and teaching in a school where one was not authorised to teach.⁷³

⁶⁶ Ibid, Section 33.

⁶⁷ Ibid, Section 41.

⁶⁸ Ibid, Section 42.

⁶⁹ Ibid, Section 51.

⁷⁰ Ibid, Section 62.

⁷¹ Ibid.

⁷² Ibid, Section 64.

⁷³ Ibid, Section 65.

Figure D: Governance of schools and teachers management under Education Ordinance of 1952

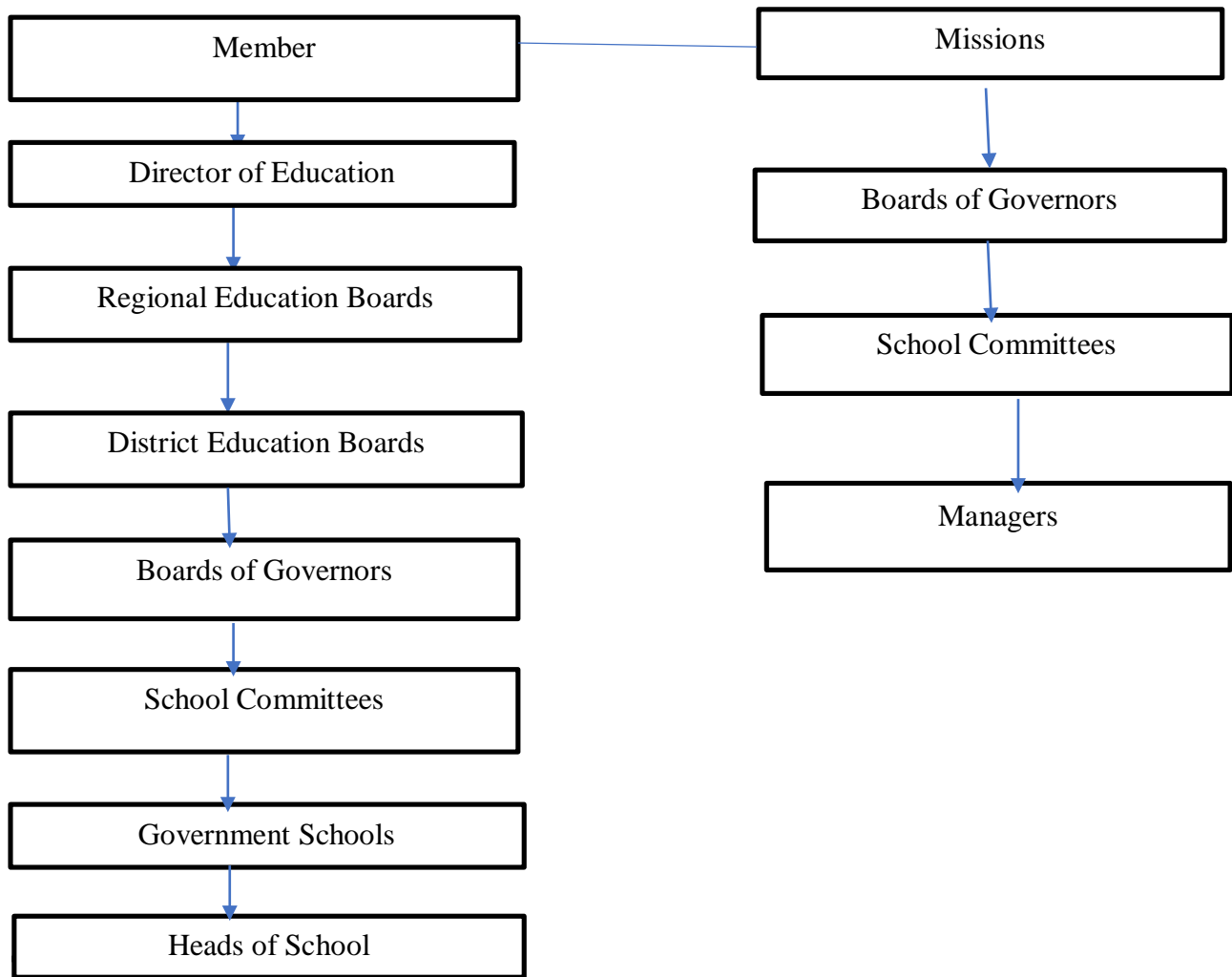

In April 1954, the Ministry of Education, Labour and Lands was established and a Minister for Education appointed.⁷⁴ The Minister had the responsibility of overseeing the Educational policy formulation in the council of ministers and the legislative council. The Minister was to be assisted by two permanent civil servants; the Secretary for Education, Labour and Lands and the Assistant Secretary for Education.⁷⁵ A parliamentary Secretary for the portfolio was also appointed. In

⁷⁴ *Colony and Protectorate of Kenya, Education Department Annual Report 1954*, (Government Printers Nairobi).

⁷⁵ *Ibid.*

policy formulation, the Minister was to be assisted by advisory councils for African, Arab, Asian, European, Higher⁷⁶ and Technical Education.

The Execution of policy was the responsibility of the Director of Education, assisted by Deputy and five Assistant Directors. For local administration, the colony was divided into 5 regions, each under the charge of Provincial Director of Education. Each P.D.E had the headquarters staff of an Education Officer and an office assistant.

Figure E: Governance of schools and teacher management after 1954

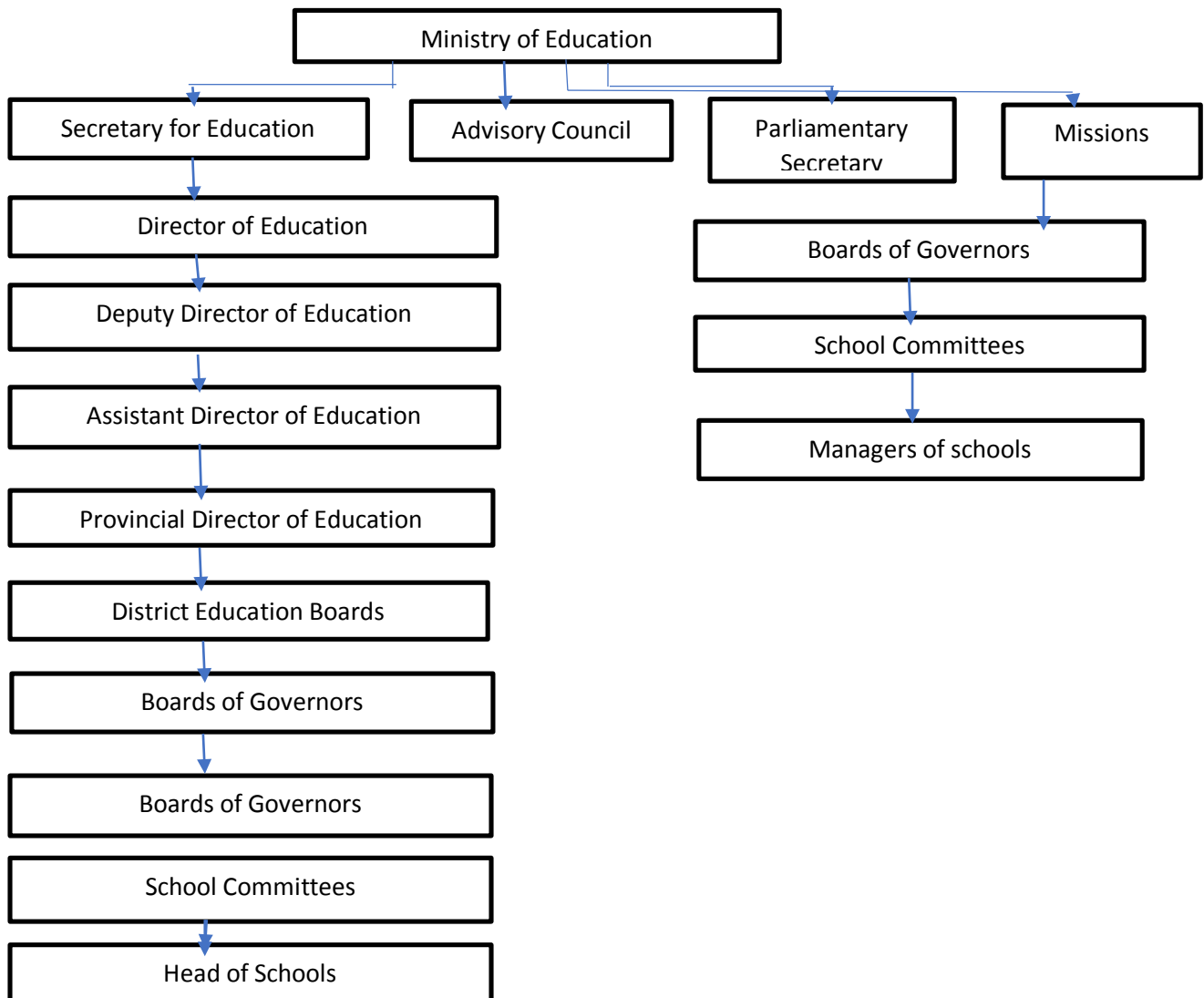

⁷⁶ Supra note 36.

In April 1961, a commission under the Chairmanship of Dr. B.E Lawrence visited Kenya.⁷⁷ It was appointed to examine and report on the remuneration of teachers, their conditions of service and the probability of establishing a unified teaching force. The commission recommended that all future recruitment of teachers be done by a unified disestablished teaching service so that there would be no new civil service teachers. It further proposed that the grading of all teachers in the unified service should be based on a common basis of qualifications and experience regardless of race or sex.

2.4 Post-Independence Period

In 1963 Kenya attained its independence.⁷⁸ The independent government inherited the colonial structures with regard to management of education but sought to align the structures with the post-independent goals. Mr Joseph Otiende was appointed the first Minister for Education in post-colonial Kenya. In 1964, the Minister appointed a commission led by Professor Simeon H. Ominde with the express mandate of restructuring the entire education spectrum in order to advise government on the formulation of education policies in post-independent Kenya.⁷⁹

The Ominde commission recommended that government partners with local and regional authorities in administration of education.⁸⁰ It proposed that all maintained primary schools be managed by local authorities subject to the duties of sponsorship to be exercised by churches on the request of parents.⁸¹ It observed that head teachers had a vital supervisory role and were to be trained for that purpose.⁸² On appointment of teachers, the commission recommended that Boards of Governors control the selection of mission teachers who must be appointed to the service of the

⁷⁷ Ministry of Education Annual Summary, 1961.

⁷⁸ Great Britain Colonial Office, Kenya Independence conference 1963. (Command 2156). His Majesty's Stationary Office. 1963 P.17

⁷⁹ Kenya Education Commission Report 1964(Part one).

⁸⁰ Ibid, Para. 2(Part one).

⁸¹ Ibid, Para. 30(Part one).

⁸² Ibid, Para.33.

Boards under proper secondment agreements.⁸³ On unaided schools, the commission recommended that they should be controlled by government and the law strengthened to prevent the collection of large profits by the managers of such schools.

The post-colonial period witnessed the growth of harambee schools, which were put up through the concerted efforts of local communities. The growth of these schools is attributed to the desire by local communities to raise literacy levels in the post-independent Kenya. The Sessional Paper Number 10 of 1965 underscored the need to align education goals to the aspirations of the independent nation, which included declaration of war against ignorance, as observed by Mzee Jomo Kenyatta in his inaugural address to the Nation as the first President.

The regulation of these schools posed a challenge. Since government did not participate in their establishment, management was left in the hands of founding communities. The Ominde commission underscored the need to regulate both harambee and unaided schools. It cited unqualified teachers and low morale in the teaching profession due to poor pay and working conditions as a hindrance for attainment of education goals.

In 1967, Parliament passed the Teachers Service Commission bill which was later assented into law. The Act sought to establish a single employer and unify terms of service for all teachers. The Act established a Teachers Service Commission whose members were all appointed by the Minister.⁸⁴ The functions of the commission were to register, recruit and employ teachers in public school and discipline teachers. The Minister had supervisory powers over the commission and would give directions of a general character as to the performance and exercise by the commission of its functions.⁸⁵ The commission assigned teachers to both government schools as well as schools

⁸³ Ibid, Para.72.

⁸⁴ Ibid, Section 3(2).

⁸⁵ Ibid, Section 5.

maintained by the local authorities. Whereas teachers in government schools were paid by the government, those assigned to schools maintained by local authorities were paid by their respective Local authorities. At the end of every year, the commission was to make a report to the minister regarding performance of its functions in that year.

On 6th February 1968, the President assented to the Education Bill, paving way to an Act that would provide for the regulation and progressive development of education. The Act gave the Minister for Education powers to formulate policy, promote education and secure effective cooperation and control of all public bodies concerned with education⁸⁶. In order to effectively discharge his roles, the Act gave the Minister Power to establish an advisory council to advise him on matters concerning education.⁸⁷

In management of education, the Minister had the discretion of assigning a function to a local authority.⁸⁸ The primary schools maintained by a local authority were to be managed by that local authority while maintained or assisted schools other than a primary school were to be managed by a Board of Governors.⁸⁹ For the schools that were maintained but not managed by the local authority prior to the coming into effect of the Education Act, the Manager of the school had to either hand over the management of that school to the local authority, which was to manage and maintain the school or continue maintaining the school as unaided school.

Since missionaries had handed over some of their schools to the government, the Act provided that where a transferred school was managed by a church or a group of churches, the former manager was to be appointed by the local authority to serve as the sponsor to the school.⁹⁰ The rationale of

⁸⁶ Education Act CAP 211, Section 3.

⁸⁷ Ibid, Section 4.

⁸⁸ Ibid, Section 5.

⁸⁹ Ibid, Section 6.

⁹⁰ Ibid, Section 8.

retaining former managers as sponsors was to maintain the religious traditions of the school. Local committees were formed to help local authorities in the management of primary schools.⁹¹ For public schools, other than primary schools managed and maintained by a local authority, responsibility of their management was vested in Boards of Governors.

The Education Act of 1968 brought about the idea of school inspection and required the Minister to appoint officers who would have authority to enter and inspect any school.⁹² The Act retained the District Education Boards which had been brought about by the District Education Boards Ordinance of 1934. The Minister was to appoint the Chair of the D.E.B from amongst the members while the District Education Officer became the secretary. In practice, District Commissioners assumed the role of Chairpersons of the D.E.Bs throughout the country.

The D.E.Bs were tasked with preparing for approval, the estimates of revenue and expenditure, receiving grants or grants-in-aid from public funds, advising the minister on establishment of new schools and superintend the management of public schools. ⁹³ Establishment of new schools was to be approved by the Boards before being forwarded to the Minister.

⁹¹ Ibid, Section 9.

⁹² Ibid, Section 18.

⁹³ Ibid, Section 31.

Figure F: Governance of schools and teacher management after 1967

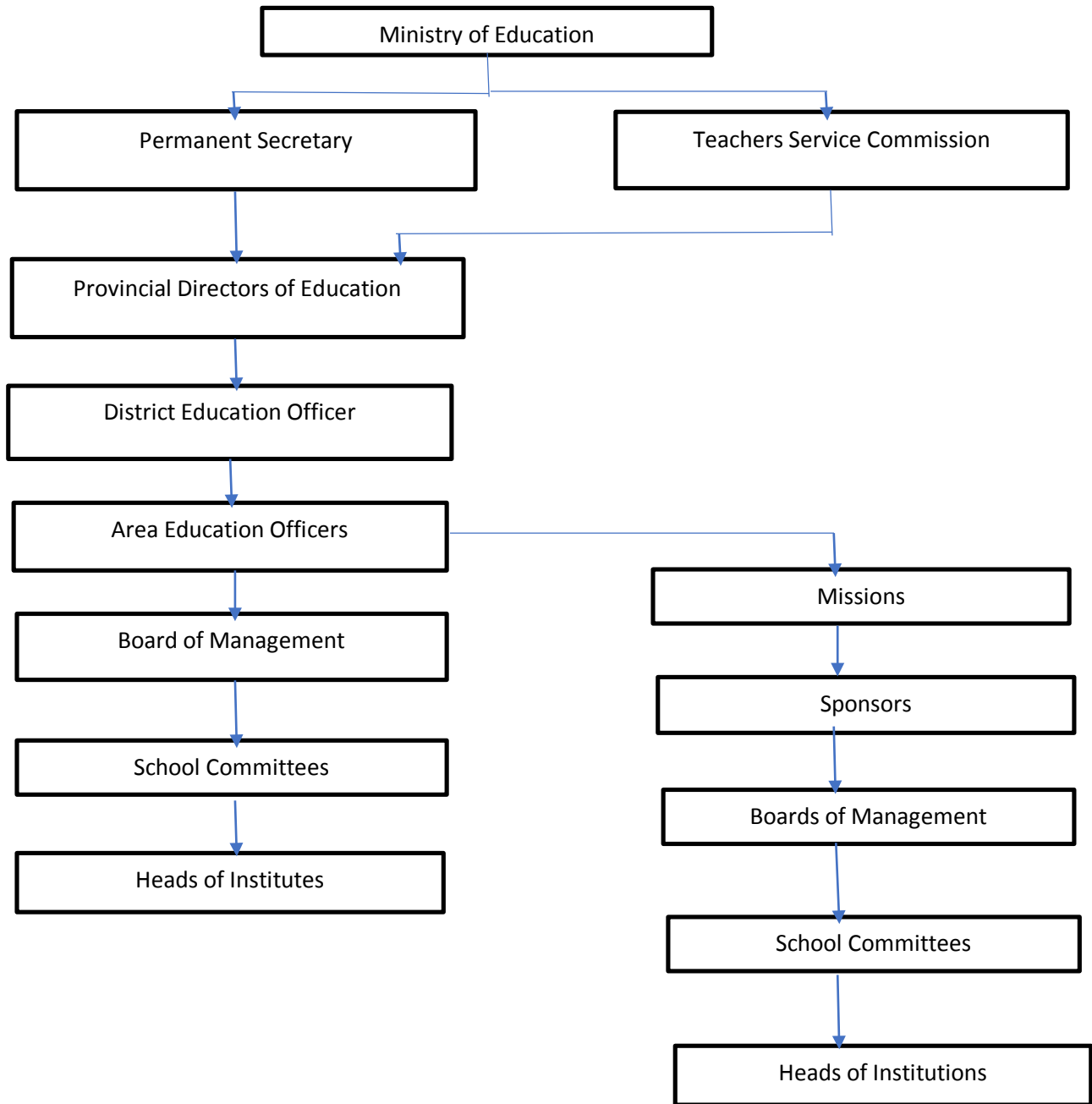

Source: Author.

The Ndegwa report of 1971 proposed the introduction of double streams in secondary schools to meet the growing demand for secondary education.⁹⁴ This led to increased enrolment against a smaller teaching service. The effect of this is that Boards of Governors had to hire teachers and pay them in order to sustain the student population. This trend continues to date.

The Gachathi Commission⁹⁵ observed that although secondary schools were run by Boards of Governors, the Boards were limited in terms of staff appointments, admission of students and discipline of both staff and students. The functions of teacher recruitment and discipline were still centralised at the Teachers Service Commission. The committee suggested delegation of those functions in order to enhance effective management especially in enhancing discipline. It further observed that the Education Act had not spelt out the relationship, in terms of delegation of managerial powers, between Boards of Governors, School committees and District Education Boards.

The Kamunge Commission⁹⁶ recommended in-service courses for school inspectors. This was to help equip the inspectors with necessary skills that would help them in performance of their functions. It further proposed the abolishment of categorisation of schools as high and low-cost schools. All secondary schools developed and equipped by government and with teachers paid from public funds were to be designated as public schools. To give effect to the recommendations of the Kamunge Commission, the government integrated harambee schools into the national public Secondary Education in 1990. As a result, the harambee schools received government funding. New categorisation of schools was initiated with national schools' category being retained. Most

⁹⁴ Report of the Commission of Inquiry (Public Structure and Remuneration Commission) 1970-1971.

⁹⁵ National Committee on Educational Objectives and Policies.

⁹⁶ Presidential Working party on Education and Manpower Training for the Next Decade and Beyond, 1986.

assisted schools were renamed provincial schools and the rest, including unaided schools renamed District schools. Integration led to increased government support as well as supervision.

In 1999, the Koech Commission⁹⁷ proposed an expansion of the scope of basic education by making secondary education part of basic education.

In 2003, the Ministry of education convened a national conference on education and training which led to the development of a new policy framework. The policy framework, Sessional Paper number 1 of 2005 outlined the guidelines and policies that were aimed at improving access, quality and equity in secondary education. This called for increased government involvement in terms of funding and supervision. The Gachukia report of 2007⁹⁸ led to a massive infrastructural development with a focus on tuition blocks. Further, it gave rise to new day schools in urban slums, rural areas and highly populated urban centres.

2.5 Post 2010 Period

The Constitution of Kenya 2010 brought about a paradigm shift in teacher management and governance of schools in Kenya. It recognised the right to education as a fundamental constitutional right and elevated the Teachers Service Commission into an independent constitutional commission. Prior to that, TSC had existed as an appendage of the Ministry of Education, with commissioners being answerable to the Minister and serving at his discretion. As an independent commission, TSC was assigned an exclusive constitutional mandate of teacher management. In 2012, Parliament enacted the Teachers Service Commission Act Number 20 of 2012, repealing Teachers Service Commission Act, Chapter 211 of Laws of Kenya. The new Act made further provisions for the Teachers Service Commission as established under Article 237 of

⁹⁷ The Commission of Inquiry into the Education System of Kenya, 1999.

⁹⁸ Report of the Taskforce of Affordable Secondary Education in Kenya.

the Constitution, providing for its composition, functions, powers, qualifications as well as procedure for appointment of members.

In 2013, Basic Education Act⁹⁹ was enacted to give effect to Article 53 of the Constitution in terms of regulating free and compulsory basic education as well as providing a legal framework for registration, governance and management of institutions of basic learning. Through the Act, the Cabinet Secretary retained the role of policy formulation and governance of public schools. The Act abolished District Education Boards, replacing them with the County Education Boards and renamed Boards of Governors as Boards of Management, seeking to professionalise the new Boards by setting qualifications for membership.

The Cabinet Secretary for Education gazetted Basic Education Regulations in 2015 so as to operationalize the Basic Education Act. The regulations gave criterion for formation of Boards of Management and gave head teachers powers to be in charge of day to day management of public schools as agents of the Ministry of Education. In 2015, TSC gazetted the regulatory framework for the teaching profession.¹⁰⁰

The Basic Education Act, 2013 and the Teachers Service Commission Act, 2012 are not in consonance in relation to teacher management and governance of public schools. The two statutory instruments run parallel to each other. Teachers Service Commission Act makes provisions on teacher management without appreciating the role of the Ministry. This apparent omission creates a perception that the Ministry of Education has no role to play in teacher management. Unlike before 2010 when the Minister was the overall centre of command in teacher management, the current legal framework requires the Cabinet Secretary for Education to deal with teachers through

⁹⁹ Basic Education Act No.14 of 2013.

¹⁰⁰ Teachers Service Commission (Code of Conduct and Ethics for Teachers) Regulations, 2015.

the Commission. When the Commission existed as a semi-autonomous agency at the Ministry of Education, the coordination of teacher management and governance of schools appears to have been smooth. Tensions seem to have begun immediately the Commission was recognised as an independent entity under Chapter 15 of the Constitution of Kenya 2010 and assigned all teacher related functions.

2.5.1 Role of Teachers Union in Management of Teachers

The first teachers Union was formed in 1934 by James Gichuru and Eliud Mathu.¹⁰¹ The organization, Kenya African Teachers Union (KATU) did not survive the test of time.¹⁰² This was occasioned by communication barriers and the fear of teacher employers to have a united Teachers Union. After the collapse of K.A.T.U, teachers began forming sectional and regional organizations-based on provinces or denominations. They included Nyanza African Teachers Union, Catholic African Teachers Association, Rift Valley African Teachers Association, Coast African Teachers Union, and Central Province African Teachers Union which was also called Kikuyu Teachers Union.¹⁰³

In 1955, Hon. Daniel Moi, a member of the Legislative Council successfully moved a freelance motion which sought to urge the government to help teachers in the country to form a national union.¹⁰⁴ In December 1957, Minister for Education Mr. F. Coutts called for a stakeholders' meeting at Pumwani D.E.B School where Kenya National Union of Teachers was formed. On 14th May 1959, KNUT was officially registered as a trade union.

Upon KNUT being registered as a trade union, its Central Executive Committee met and issued policy demands which included; a single employer for all teachers, abolition of the colonial code

¹⁰¹ Retrieved from; <http://www.knut.or.ke> <Accessed on 31st March 2018>.

¹⁰² Ibid.

¹⁰³ Ibid.

¹⁰⁴ Ibid.

of discipline, pay rise for all teachers, provision of negotiating machinery, unified terms and conditions of service, responsibility for all teachers in management. After a series of strikes to press for a single employer, the government established a Teachers' Service Commission in 1965 under the Chairmanship of Hon. Solomon Adagala.

KNUT called for a strike from 1st to 3rd November, 1966. The strike pushed the government into creating a single teachers employer. Subsequently, the Teachers Service Commission was established through a bill introduced in parliament by Minister for Education by Jeremiah Nyagah.¹⁰⁵

2.6 Conclusion

Teacher management and governance of public schools in Kenya dates back to the colonial times. Before 1924, there was no legal framework governing both teacher management and governance of schools. Government control of education begun in 1911 when the Colonial government created Education department and appointed the first Director. Even after the appointment of the first Director of Education, missionaries played a crucial role in both the governance of schools and management of teachers. Since missionaries put up their schools, government gave them a free hand in choosing managers of those schools. The school managers were in charge of teacher recruitment. With the coming into force of the Education Ordinance of 1924, Government in essence, took over the overall management of schools in terms of policy development. The ordinance introduced the concept of classification of schools into Government schools, which were established and maintained by the government, Public schools, which were either established or maintained by the government and the private schools which were institutions that did not receive

¹⁰⁵ Teachers Service Commission Act, CAP 211 of Laws of Kenya (Now repealed).

any support from public funds. The subsequent amendments to the ordinance brought on board more stakeholders hence restructuring governance of schools and teacher management.

This chapter demonstrates that until the promulgation of the Constitution of Kenya 2010, teacher management and governance of schools had been a collective duty of the Ministry of Education. Teachers Service Commission was treated as an extension of the Ministry, as the commissioners were answerable to the Minister.

CHAPTER THREE

POLICY, LEGISLATIVE AND INSTITUTIONAL FRAMEWORK GOVERNING TEACHER MANAGEMENT AND GOVERNANCE OF PUBLIC SCHOOLS IN KENYA

3.0 Introduction

This chapter examines the policy, legislative and institutional framework for teacher management and governance of public schools under the Kenyan legal framework. It interrogates the efficiency of existing laws and institutions in the post 2010 period. The Constitution of Kenya 2010 gave birth to a regime of laws that have changed the manner in which teachers are managed and public schools governed. The legal instruments that will be discussed under this chapter include the Constitution of Kenya 2010, TSC Act 2012, Children's Act, and TSC Code of Regulations for Teachers, The Basic Education Act, 2013 and Basic Education Regulations 2015.

The chapter outlines international instruments that are key to provision of education. These instruments include the Convention on the Rights of the Child and the African Charter on Rights and Welfare of the Child. It analyses key policy framework, statutes and regulations relating to teacher management, institutional framework for teacher management, legal framework for governance of schools as well institutions tasked with management of schools. It explores the tensions brought about by failure of TSC Act, 2012 and Basic Education Act, 2013 to provide for a framework of engagement between TSC and MoE on teacher management and governance of schools.

3.1 International Legal Framework

International treaties and conventions relating to education require states to take positive measures in ensuring realization of free education to all.

3.1.1 Convention on the Rights of a Child

The Constitution of Kenya 2010 incorporates customary international law and international treaties that Kenya has ratified into its legal system.¹⁰⁶ CRC requires equal treatment of all children irrespective of any ground that may lead to discrimination.¹⁰⁷ State parties, through their relevance agencies are to give effect to the rights of the child under the convention. The rights include preservation of the child's identity their free speech and privacy.

The Convention further provides that all children have a right to primary education which should be free.¹⁰⁸ Whereas the convention underscores the need of discipline among children, it emphasizes that discipline in schools should respect the dignity of a child. Governments must therefore ensure that school administrators review their discipline policies and eliminate forms of discipline involving physical and mental violence. While developing national policies on education, the convention provides that governments should ensure it provides education that develops a child's personality, talents and abilities.¹⁰⁹ Further, the kind of education offered should be geared towards helping children appreciate societal values. The government of Kenya has demonstrated this through the Basic Education Act.¹¹⁰

3.1.2 United Nations Convention on the Rights of Persons with Disabilities, 2006

This convention protects the rights of every person with disability. It provides that every child with disability has a right to education, with reasonable accommodation of his or her needs with the view to providing education for all.¹¹¹ The state parties are therefore required to ensure inclusive education system at all levels and lifelong learning. In addition, the Convention further provides

¹⁰⁶ Ibid, Article 2(5 and 6).

¹⁰⁷ Ibid, Article 2.

¹⁰⁸ Ibid, Article 28.

¹⁰⁹ Ibid, Article 29.

¹¹⁰ Act No. 4 of 2013.

¹¹¹ Article 24.

that children or adults living with disabilities should not be excluded from the education system based on disability and that they must be given the opportunity to learn the life and social development skills they need.

3.2 Regional Legal Framework

3.2.1 African Charter on Rights and Welfare of the Child

African Charter on Rights and Welfare of the Child ¹¹² was developed after the adoption of the Convention on the Rights of the Child. The rights provided in the Charter are a replica of those provided under CRC with exception of a few. The most outstanding provision under the charter is the requirement that Governments make considerations for female, gifted and disadvantaged children. It further requires governments to accord special protection to children who are mentally and physically handicapped.

3.3 Policy Framework

3.3.1 Education Policy Evolution and Implementation in Kenya

Kenya has made significant strides in education sector through policy development and implementation. These outstanding achievements are as a result of taking heed and implementing the recommendations tabled by various commissions, committees and taskforces on education and training. However, regardless of the great victories, the Education sector still faces various setbacks emanating from the demands of the 21st Century, Vision 2030 and the nascent Constitution of Kenya, 2010.

The major education reports that have significantly impacted education and training in Kenya include the Ominde report¹¹³ whose main objective was to refashion the education system inherited

¹¹² Adopted by Organization of African Unity in 1990 and entered into force in 1999.

¹¹³ Kenya Education Commission Report, 1964; Government Printer, Nairobi.

from the colonial government so as to conform to the needs of the new independent nation. The commission laid a foundation on which post-independent education system rested. The Mackay Report¹¹⁴ recommended the establishment of 8:4:4. The Kamunge Report¹¹⁵ channeled its focus on improving financing of education, quality and relevance. The Koech Report¹¹⁶ recommended that education should be designed to foster national unity and holistically equip learners

Sessional Paper No. 1 of 2005¹¹⁷ led to reforms through a Sector Wide Approach to Planning (SWAP). However, the expected returns of investment in education have not been fully realized yet emphasis was put on strengthening governance in the education sector.

3.3.3 Sessional Paper No. 14 of 2012.

This policy paper underscores the importance of education as a fundamental human right. It outlines the national goals for education to include promotion of nationalism, patriotism and national unity, promotion of individual development, social equality, and respect for Kenya's rich and varied culture, promotion of international consciousness and environmental protection.

On governance and management of basic education, the policy identified challenges in the education sector to include poor management, lack of accountability and bureaucracy in decision making. In addition, it noted insufficient authority wielded by institutional governance organs such as B.o.Gs, PTAs and School Management Committees as a factor contributing to bad governance. To address the challenges, the government the government undertook to establish the National Education Board whose role was to advise the CS on education matters, establish County Education Boards to manage education at county level and establish a system, of tracking learners

¹¹⁴ The Report of the Presidential Working Party on the Second University in Kenya, 1981.

¹¹⁵ The Report of the Presidential Working Party on Education and Manpower Training for the Next Decade and Beyond, 1988.

¹¹⁶ The Report of the Commission of Inquiry into Education System of Kenya, 1999.

¹¹⁷ Sessional Paper No. 1 of 2005: A Policy framework For Education, Training and Research

from pre-primary levels through basic level of education. In implementing the foregoing policies, the government undertook to delegate the delivery of basic education to County Education Boards, create the position of Director General of Education, and rationalize Semi-Autonomous government agencies responsible for development and management of various aspects of education.

This policy paper informed the enactment of Basic Education Act¹¹⁸ which reviewed governance and management structures, created NEB and CEB, Created the position Director General of Education and established national council for quality assurance and maintenance of standards. In essence, the Basic Education Act sought to give effect to the Constitutional provisions on Education.

On teacher management, the policy identified challenges to include inefficiency in teacher registration, teacher shortages in public education institutions occasioned by increased enrollment and establishment of new schools under CDF programs and the stakeholder interference in teacher deployment. To address the challenges, the government undertook to conduct continuous teacher rationalization and controlled establishment of new schools.

3.3.4 Sector Policy for Learners and Trainees with Disabilities 2018

This policy has been developed with view to promoting provision of education and training for learners with disabilities. The scope of the policy covers learners and trainees with disabilities including those with hearing impairment, visual impairment, deaf-blindness, physical impairment, intellectual and development disabilities, specific learner disabilities including dyslexia, dyscalculia, dysgraphia, cerebral palsy, speech and language disabilities, multiple disabilities,

¹¹⁸ Act No. 14 of 2013

autism and albinism. The policy also acknowledges other forms of special needs such as giftedness and talentedness, psychosocial disorders and chronic illness. To achieve its objectives, the policy has identified thematic in provision of special needs education to include assessment and early intervention, access to quality and relevant education, quality learning environment, advocacy and awareness creation, equity and gender mainstreaming, public participation and engagement and institutional implementation framework for the sector policy. The policy underscores the need for Kenya to move towards inclusive education as opposed to segregated education. Inclusive education requires that learners with special needs are enrolled in same classroom together with their peers without disabilities. This shift recognizes the important role of other approaches such as special institutions of learning, special units in regular institutions of learning and home-based education in providing education specifically for learners with severe disabilities.

Policy makers, heads of institutions and boards of management are required to be awake to this policy paper when making managerial and governance decisions.

3.5 Domestic Legal Framework

3.5.1 Constitution of Kenya 2010

The Constitution of Kenya 2010 provides that every child has a right to free and compulsory basic education.¹¹⁹ This Article places an obligation on Government to ensure every child of school going age accesses quality education. In order to achieve this, government has designated the Ministry of Education to give effect to this Article. The Constitution contemplates the office of the Cabinet Secretary who is to be in-charge of Education matters.¹²⁰ In governance of schools, the persons responsible are to be awake to the National values and principles of governance which

¹¹⁹ The Constitution of Kenya 2010, Article 53.

¹²⁰ Ibid, Article 152(1).

include good governance, integrity, transparency, accountability and sustainable development.¹²¹The Constitution makes provisions on children's right to free and compulsory basic education, including quality services and access to education¹²²

The Constitution makes fundamental provisions on land.¹²³ These provisions are relevant since educational infrastructure is constructed on public land and or community land and public schools need to hold title of the land on which they are established. This provision poses on major challenge on how to deal with missionary schools that have been handed over to government in terms of management even though title to land remains with the sponsor. Whereas the law requires that every school should have title to their land registered under the school name, the sponsoring churches are reluctant to transfer title to the institution's name. This is a potential area of conflict between the Ministry of Education and Sponsors in governance of schools.

On Public finance, the Constitution makes provisions on transparent and accountable use of public funds.¹²⁴ Heads of institutions are required to be guided by these provisions. The Ministry disburses funds to schools, which funds are administered by heads of institutions deployed by the Teachers Service Commission. There is no clear framework on how the Cabinet Secretary for Education should hold responsible heads of institutions who do not subscribe to the Constitutional principles on public finance.¹²⁵ On Management, the Constitution provides for the values and principles of public service. Boards of Management and Parents association are to be guided by these principles in discharge of their mandate.

¹²¹ Ibid, Article 10(2).

¹²² Articles 53, 54,55,56,57 and 59.

¹²³ Articles 62 and 63.

¹²⁴ Articles 201(a), (d), 226 and 227.

¹²⁵ Basic Education Regulations 2015 require that instances where the Cabinet Secretary as established impropriety on the part of the head of institution, he should request Teachers Service Commission for a replacement.

The Teachers Service Commission is a creature of the Constitution of Kenya.¹²⁶ As a Commission under Chapter fifteen, it has a constitutional mandate to protect the Sovereignty of the people and promote constitutionalism.¹²⁷ TSC is subject only to the Constitution and is not to discharge its functions under the direction or control of any person or authority.¹²⁸ The foregoing provision limits the powers of the Cabinet Secretary for Education in teacher management. This is a departure from the past when TSC existed as a semi-autonomous agency under the Ministry of Education, Science and Technology prior to the Promulgation of the Constitution of Kenya 2010. As a semi-autonomous agency, TSC was answerable to the Minister of Education. Decisions of the commission were subject to review by the Minister for Education.

The functions of TSC are registration of trained teachers, recruitment and employment of registered teachers, deployment of teachers to public schools, transfer, discipline and termination of employment of teachers.¹²⁹ In addition, the commission advises the National government on matters relating to the teaching profession, reviews qualifications of persons joining the teaching profession as well as reviewing the supply and demand of teachers.

The Constitution is the supreme law of the Republic and all other laws must conform to it.¹³⁰ The implication of this provision is that no other entity can purport to carry out duties that are assigned to TSC by the Constitution. Any section of an Act of parliament or regulation that makes a provision with respect to the functions of TSC must be in consonance with Article 237 of the Constitution. The Cabinet Secretary for Education is also required to discharge his duties taking cognizance of the Constitutional functions of the commission. Since the CS historically yielded

¹²⁶ The Constitution of Kenya, 2010, Article 237.

¹²⁷ Ibid, Article 249 (1).

¹²⁸ Ibid, Article 249 (2).

¹²⁹ Ibid, Article 237 (2).

¹³⁰ Ibid, Article 2.

such immense powers over TSC when it existed as a semi-autonomous agency within the Ministry of Education, it is not uncommon to find the Ministry and TSC encroaching on the functions of each other. Until 2010, the decisions of the commission were made in consultation with Minister for Education.

In *Elimu Yetu Coalition v. Teachers Service Commission and 2 others*¹³¹, the High Court restated the supremacy of TSC over teacher management functions. The petitioner had moved to court to challenge the powers of TSC in appointing heads of institutions, arguing that it was the responsibility of the Ministry of Education to appoint heads of institutions. The court held that the plain reading of Article 237 vested in TSC all powers relating to deployment and promotion of teachers, including the appointment of head teachers. The Constitution provides that a child's best interests are of paramount importance in every matter concerning the child.¹³²

3.6 Teachers Service Commission Act No. 20 of 2012

Parliament enacted Teachers Service Commission Act in 2012 to give effect to Article 237 of the Constitution by providing for the constitution, composition and functions of TSC. The Act provides for the procedure of nomination and appointment of commissioners.¹³³ The Commission consists of a Chairperson and eight other commissioners appointed in accordance with the Constitution and the provisions of the Act. Unlike under the old Constitutional order where the commissioners were appointed by the Minister at his discretion, the current legal framework contemplates an independent selection process that brings on board various stakeholders.¹³⁴

The Act requires Parliament to vet the names of persons forwarded to the president by the Nominating Panel before their appointment. By bringing on board parliament, the framers of the

¹³¹ High Court Petition No.31 of 2015 at Nairobi.

¹³² Ibid, Article 53.

¹³³ Teachers Service Commission Act 2012, Section 10.

¹³⁴ Ibid, Section 8(2).

Constitution intended to create a participatory process where the people could be allowed to make presentations about persons nominated to the commission. The commission is mandated to develop policies aimed at helping it achieve its mandate, to conduct and monitor the performance of teachers and facilitate professional development of teachers in the teaching service.¹³⁵ The commission has a secretariat headed by the Secretary who is the chief accounting officer and custodian of all records of the commission.¹³⁶ It is mandatory that all persons engaged in the teaching service be registered under the commission.¹³⁷ The commission requires registered teachers to undertake professional development and career progression as prescribed by regulations.¹³⁸

The Act empowers the commission to develop regulations for efficient discharge of its core mandate. The regulations may relate to appointment and discipline of the staff of the commission, setting of conditions relating to admission to and removal from the register of teachers and the management and administration of the function of discipline of registered teachers.¹³⁹ In exercising its disciplinary mandate over teachers, the commission is not bound by strict rules of evidence and the burden of proof under the criminal law. In the case of *Teachers Service Commission versus Joseph Wambugu Nderitu*,¹⁴⁰ the court held that a successful outcome of a criminal process against an employee has no primacy over an internal disciplinary process against such an employee arising from the same circumstances.

The Act fails to provide a legal framework of engagement with the Ministry of Education on management and governance of schools. It is not practically possible for the Ministry to effectively

¹³⁵Ibid, Section 11.

¹³⁶ Ibid, Section 16.

¹³⁷Ibid, Section 23 (2).

¹³⁸ Ibid, Section 35.

¹³⁹Ibid, Section 47.

¹⁴⁰ In The Court of Appeal at Nyeri, Civil Appeal No.53 of 2014.

supervise governance of schools without engaging teachers on regular basis. This regular engagement without a clear framework has resulted to tensions between the Commission and the Ministry.

3.7 Teachers Service Commission Code of Regulations for Teachers, LN No. 196 of 2015

Pursuant to Section 47(2) of the TSC Act, the commission drafted regulations to help streamline the teaching service. The regulations make provisions for the decentralisation of the functions of the Commission, delegation of duty by the commission, registration of teachers, development, review and maintenance of entry and performance of entry and performance standards, promotion of teachers and teachers benefits and discipline. Before the promulgation of the Constitution of Kenya 2010, functions of TSC were centralised at the headquarters, with provincial Directors of Education playing peripheral roles on behalf of the commission. With decentralisation, TSC has devolved its functions to county and sub-county levels. The decentralised units of the commission are meant to exclusively handle teacher-related functions. Under the code, there are no provisions on how the decentralised units of the commission are to relate with the Ministry of Education units at the county and sub-county levels.

3.8 Teachers Service Commission (Code of Conduct and Ethics of Teachers)

Regulations, LN No. 162 of 2015

These regulations focus on the conduct and ethical behaviour of teachers in the course of their service. Under the Regulations, teachers' duties go beyond classroom teaching. A teacher is entrusted with the care of a child and has to take reasonable steps to ensure the child is protected from neglect, abuse, discrimination, inhuman treatment, corporal punishment and all other forms of harmful cultural practices.¹⁴¹

¹⁴¹ Teachers Service Commission (Code of Conduct and Ethics for Teachers) Regulations, 2015 Reg.9.

3.8.1 Institutional Framework for Teacher Management.

There are various institutions responsible for teacher management under the Teachers Service Commission Act.¹⁴² They include the commission Secretariat, Office of the County Director and the Sub-county Director. The commission also delegates functions to agents such as Boards of Management in discharge of its mandate.

3.8.2 The Secretariat

The Secretariat is based at the headquarters and headed by the Chief Executive Officer. It is at the apex of the administrative pyramid of the commission. The CEO is the chief accounting officer of the commission. The occupant of the office executes the decisions of the commission, assigns duties to and supervises the staff of the commission, ensures compliance with public ethics and values, ensures execution of the commission's mandate and takes charge of the general administration of the commission.¹⁴³ Even though the functions of the commissions have been decentralised to county and sub-county levels, the key administrative duties have been retained at the headquarters.

The commission by decentralising its functions, acted in compliance with Article 174 of the Constitution which underscores the need for devolution. The decentralisation of teacher management is aimed at ensuring equity in staffing, improving access to the commission's services, helping achieve effective teacher career development and promoting engagement with stakeholders in teacher management.

¹⁴² Act Number 20 of 2012.

¹⁴³ Teachers Service Commission (Code of Conduct and Ethics for Teachers) Regulation, 2015 Reg. 9.

Figure G: TSC County and Sub-county combined Technical Organizational Structure

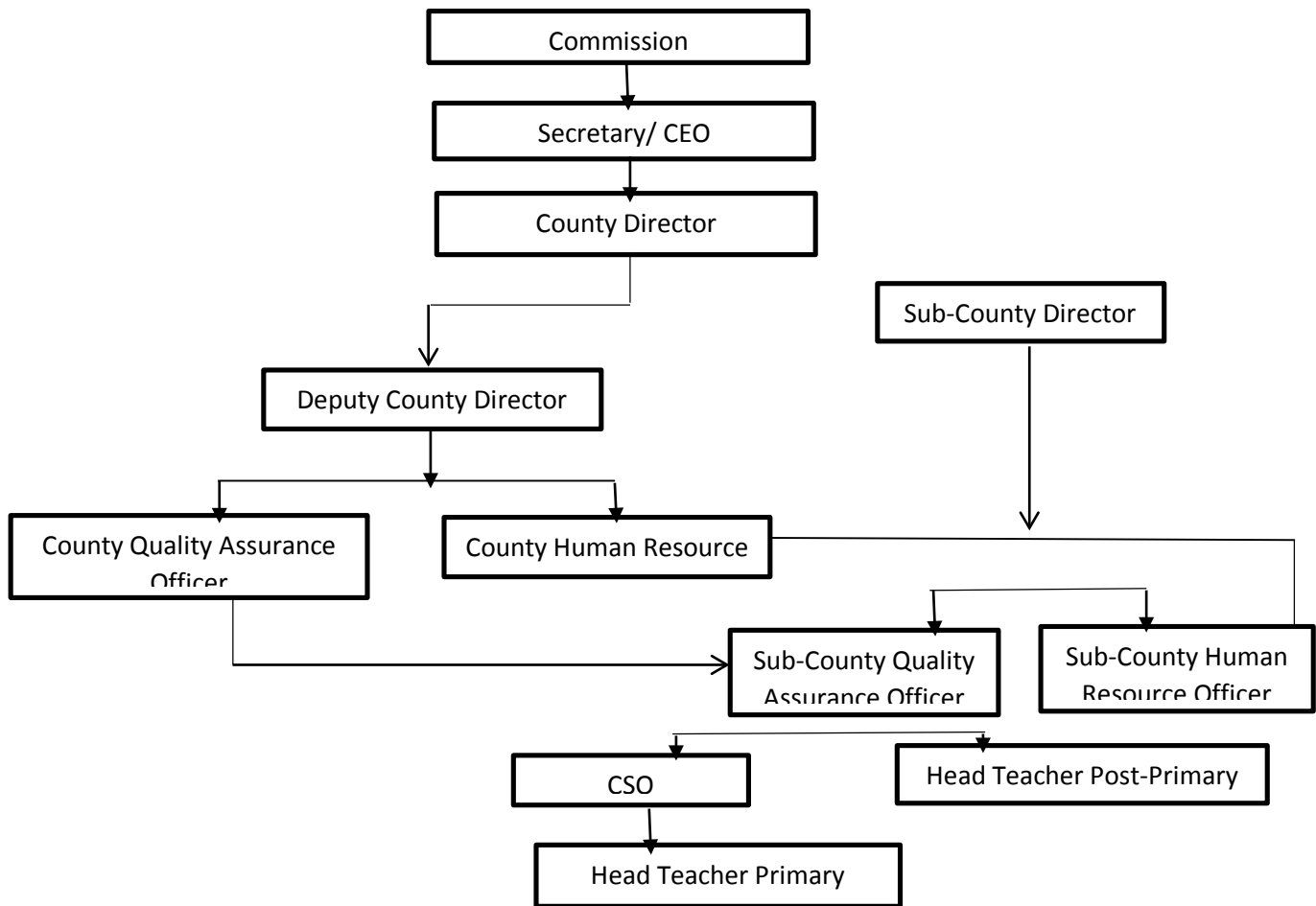

Source: Author

3.8.3 TSC County Office

Prior to devolution, Kenya was divided in eight provinces. TSC had Provincial Directors of Education as its agents at the Provincial level. Sub-division of Kenyan territory into 47 counties led to restructuring of TSC to bring it in conformity with the Constitution. As a result, the commission established offices in each of the forty seven counties. The County office is established to facilitate the processing of teacher registration, coordinate recruitment at the county, maintain a data bank for both employed and unemployed teachers at the county, implement policy guidelines issued by the commission, coordinate teacher promotion under common cadre established within the county, transmit reports from heads of schools to the commission, and

submit reports related to conduct and performance of teachers at county level.¹⁴⁴ In discharging their mandate, County Directors are answerable to the Commission Secretary at the headquarters.¹⁴⁵

A County Director is deputised in the performance of his duties by the Deputy County Director who coordinates the processing of teacher registration in the county, plans and facilitates interviews for heads and deputies as well as ratification of the appointment of heads of primary schools, establishes and maintains a data base for interviewed candidates, undertakes standards assessment in schools and acts as secretary to the county meetings.¹⁴⁶

In ensuring quality and professionalism, the County Director is assisted by TSC Quality Assurance and Standards Officer who ensures compliance with professionalism among heads of schools, ensures compliance with teaching standards by ensuring use of professional teaching resource coordination of quality assurance programmes in the county, monitors performance of heads and teachers and ensures teachers are appraised, and liaises with County Director of Education and other stakeholders on matters relating to quality of education in the county.¹⁴⁷

Additionally, County Human Resource office has been decentralized to be in-charge of the human resource function in the County, manages the correspondences on issues relating to schemes of service and advises the TSC County Director on matters relating to human resource management and development.

¹⁴⁴Teachers Service Commission (Code of Conduct and Ethics for Teachers) Regulation, 2015, Reg.12 (1).

¹⁴⁵ Ibid, Reg.11 (3).

¹⁴⁶ TSC Handbook on Decentralized Teacher Management Functions, August 2015.

¹⁴⁷ Ibid.

Figure H: TSC County Organizational/Administrative Structure

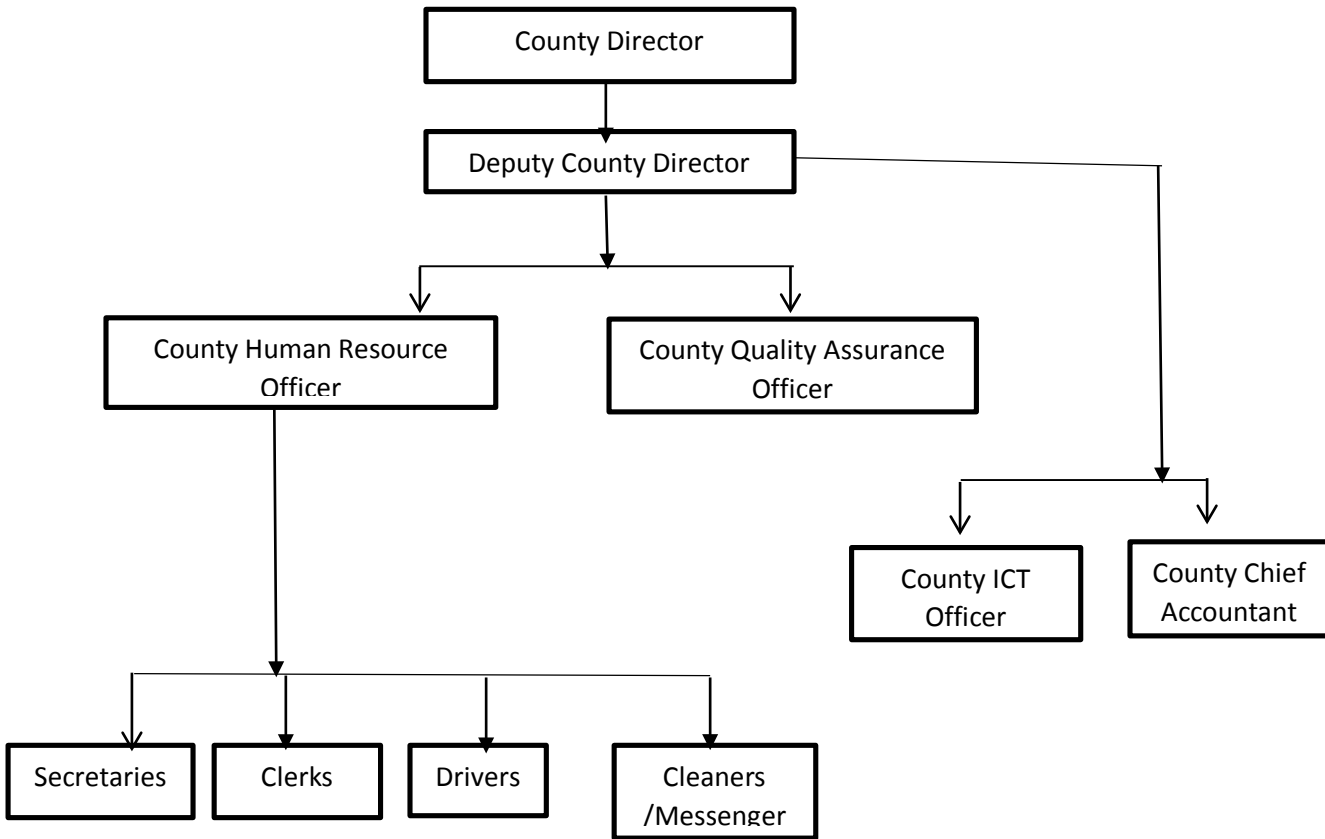

Source: Author

3.8.4 TSC Sub-County Offices

There are established TSC offices at the sub-count level. These units are headed by sub-county Directors. The Sub-county Directors are in charge of facilitating the processing of teacher registration within the sub-county, submitting data on staffing needs to the County office, deployment of teachers to public schools within the sub-county, investigation of the allegations of professional misconduct of teachers within the sub-county and receiving applications for transfer of service of teachers to public institutions and forwarding them to the County Director.¹⁴⁸

¹⁴⁸ Teachers Service Commission (Code of Conduct and ethics for Teachers) Regulation, 2015, Reg.13

Figure I: TSC Sub-county Organizational/Administrative Structure

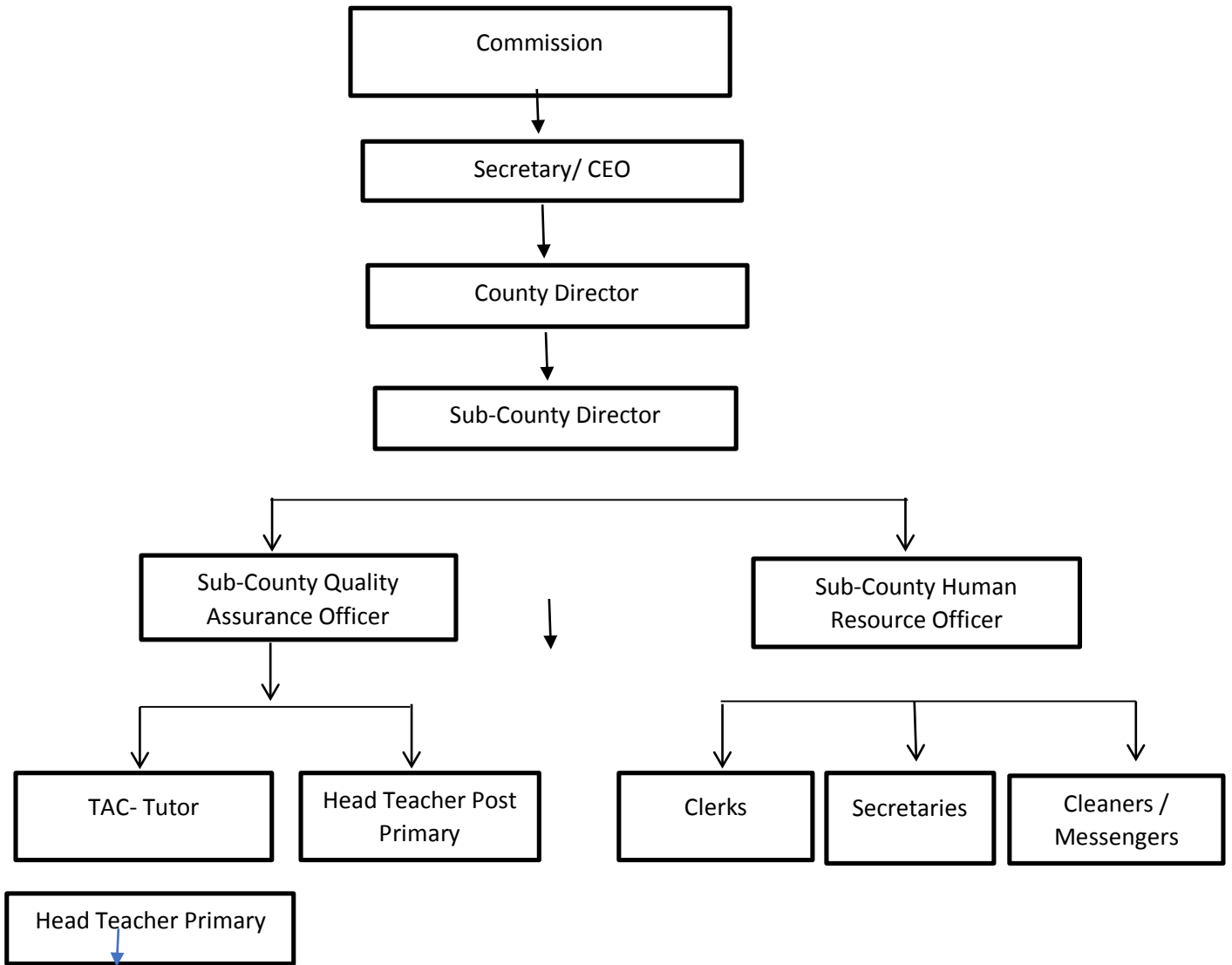

Source: Author

3.8.5 Curriculum Support Offices

At the Zonal level within a Sub-County, the commission may establish a curriculum support centre with the view of providing quality teaching and learning.¹⁴⁹ The Curriculum Support Officer is required to identify and advise the commission on the training needs of teachers and the heads of

¹⁴⁹ TSC Handbook on Decentralized Teacher Management Functions, 2015.

institutions, to offer advice on appropriate teaching resources including textbooks and taking a leading role in the organisation and Management of Co- Curricular activities.¹⁵⁰

3.8.6 Boards of Management

Boards of management play a role in teacher management as agents of the commission. TSC Code Regulations 2015 empowers the commission to delegate to the Board of Management or any other agent the role of teacher recruitment as per the guidelines issued by the commission and the exercise of disciplinary control over teachers.¹⁵¹ As agents, the Board exercises delegated authority and its decisions are subject to review by the commission.

The appointment of the agent must be in writing.¹⁵² Even though the BoM's which in essence are organs created by the Ministry of Education to manage schools on their behalf, they are at times appointed as agents of TSC for the purposes of recruitment and discipline of teachers, the commission retains the discretion of exercising any power delegated to BoMs and may revoke such delegation in writing at any time.¹⁵³ By retaining the discretion to exercise any power delegated to the Boards of Management, TSC appears to be guarding against the usurpation of powers by agents, and in particular the Ministry of Education. To these end, the decision of the Board of Management relating to teacher management can be overruled by the commission. For a Board of Management to be properly constituted for the purposes of taking disciplinary action against a teacher, TSC sub-county Director or his representative must be in attendance.

The Board, after finding the case against a teacher may warn the teacher in writing or interdict the teacher.¹⁵⁴ If the Board opts to interdict the teacher, it must serve two copies to the County

¹⁵⁰ TSC Handbook on Decentralized Teacher Management Functions, 2015.

¹⁵¹ Teachers Service Commission (Code of Conduct and Ethics for Teachers) Regulation, 2015, Regulation 14.

¹⁵² Ibid, Reg. 14(a).

¹⁵³ Ibid, Reg. 15.

¹⁵⁴ Ibid, Reg.146 (10).

Directors for onward transmission to the commission.¹⁵⁵ The Commission retains the powers to amend the letter of interdiction.¹⁵⁶

3.8.7 Heads of Institutions as TSC Agents

Head Teachers and Principals are defined as lead educators or administrators in their respective schools, appointed by the commission and responsible for the implementation of the educational policy guidelines and professional practices.¹⁵⁷ This definition tends to give the heads powers beyond teacher Management. Under the Constitution of Kenya 2010, the policy formulation and manner of implementation is a function of the Ministry of Education. Part of the friction that tends to exist between the Commission and the Ministry is the Ministry's involvement in teacher management in pursuance of its objectives under policy implementation.

The Head of Institution is responsible for compliance with professional practice, supervision and implementation of the curriculum, teacher management within an institution, Offering guidance on effective teaching supporting in the implementation of the Educational policy developed by the Cabinet Secretary, offering technical advice to the Board of Management and implementing the resolutions of the BoM in his or her capacity as the Secretary to the BoM.¹⁵⁸ By offering technical advice to the BoM, the head teacher is to ensure that any matter discussed by the Board and relating to teachers, must be dispensed with in conformity with the legal instruments relating to teacher management in Kenya. He defines the boundaries of the Board with regard to matters affecting teachers.

The Heads of Institutions are to implement the resolutions of the Board in their capacities as Secretaries. In the past, the heads were bound by resolutions of the Board because their employer,

¹⁵⁵ Ibid, Reg. 147(3).

¹⁵⁶ Ibid, Reg.147 (5).

¹⁵⁷ Teachers Service Commission Act 2012, Section 2.

¹⁵⁸ Teachers Service Commission (Code of Conduct and Ethics for Teachers) Regulation, 2015, Reg. 71(2).

TSC, was a semi-autonomous agency of the Ministry of Education. Under the current legal framework, the heads only seem to have an obligation to implement the resolutions of the Board in so far as they are consistent with their duties as appointees of the commission. For instance, a resolution by the Board asking the head to initiate the process of transferring a teacher may not be binding to the head teacher because neither the head nor the Board have powers to transfer a teacher.

3.9 Governance of Public Schools in Kenya

3.9.1 Basic Education Act, No. 14 of 2013

The Basic Education was enacted to give effect to Article 53 of the Constitution of Kenya 2010 in terms of providing for regulation of free and compulsory Education as well as governance and management of institutions of basic learning. The Act also provides for the establishment for the Education Standards and quality assurance commission and the National Education Board. The Act creates institutions responsible for the management of basic education to include National Education Board, County Education Boards, Education Standards and Quality Assurance Council and Boards of Management.

The Act provides for values and principles that are to guide provision of basic education which include free and compulsory basic education, equality in terms of access, accountability and promotion of cooperation among stakeholders.¹⁵⁹ Even though free and compulsory education seems to have taken route, the huge numbers enrolled in public primary schools seems to be impacting negatively on the quality of education.

T.S.C declares vacancies based on the availability of funds from the Treasury and does not necessarily employ based on teacher demand. One major avenue through which administrators of

¹⁵⁹Basic Education Act, Section 4.

institutions of basic learning can democratically engage other stakeholders is through annual general meetings. In such meetings, parents' representatives can democratically be elected and decisions reached through a consultative forum. The Act also seems to underscore the need for regular consultations between T.S.C, N.E.B and Boards of Management. TSC is a major player in the governance of schools because its employees, the heads of institutions are in-charge of the day to day running of schools.

The National government may, upon the request and agreement with County government transfer its functions relating to infrastructure for development of primary and secondary schools to a county government.¹⁶⁰ This provision is instructive in improving the infrastructural outlook of schools to cope with increasing enrolment in schools. In addition, this transfer of functions from National to County government brings on board the C.E.C in charge of education at County level in a supervisory position with regard to teacher management and governance in schools.

3.9.1.3 Role of Sponsor under the Basic Education Act

The Act defines a sponsor as a person or institution that makes a significant contribution and impact on the academic, financial, spiritual and infrastructural development of the institution of Basic education.¹⁶¹ The concept of sponsorship of schools' dates back to the colonial days when missionaries were major providers of education in the Kenyan protectorate. Before Government's involvement in Education through enactment of the Basic Education Ordinance of 1924, missionaries built and managed their own school, retaining appointment and control over their teachers. When the missionaries handed over their schools to government, they retained some roles such as being the custodians of the tradition of the schools and spiritual guidance.

¹⁶⁰Ibid, Section 26. This must however be done pursuant to Article 187 of the Constitution of Kenya 2010.

¹⁶¹Basic Education Act 2013, Section 2.

The role of the sponsor under the Basic Act include participation in the process of syllabus review, curriculum development, representation on the Boards of Management, advisory roles on spiritual matters, maintenance of the spiritual development of their schools and offering of financial and infrastructural support. The foregoing provisions seem to curtail the powers that sponsors yielded prior to the enactment of the Constitution of Kenya 2010. Before TSC became a constitutional commission with exclusive roles over teacher management, it was almost mandatory, by practice, to consult the sponsor before deciding on the headship of the school. The present day sponsor is only to be consulted on the management of school. The consultation is not absolute. It is qualified to the extent that the sponsor makes meaningful contribution to the school.

The case of *Mohamed Fugicha v. Methodist Church in Kenya and 3 others*¹⁶² the Appellant court was asked to make a pronouncement on the issue of the exercise of religion in public schools in Kenya. The respondent argued that it was the sponsor of St Paul's Kiwanjani mixed Day Secondary School for which it had provided a five-acre piece of land and that it had a uniform policy prescribed in the admission letter which each student had signed upon admission. The County Director of Education held a meeting with parents in the absence of the sponsor and the B.O.M and agreed that Muslim students be allowed to wear trousers and hijab and that the principal of the school be transferred because he was working in cahoots with the sponsor over the school uniform issue.

The Church considered the transfer of the principal to be malicious, irrational and punitive and complained to the relevant authorities requesting that school rules be adhered to, the principal retained and the church be respected as the sponsor. The court held that the uniform policy restricting female Muslim students from wearing trousers and hijab indirectly discriminated

¹⁶² In The Court of Appeal at Nyeri, Civil Appeal No.22 of 2015.

against them. The court further directed the Board of Management of the school to initiate consultations with other stakeholders aimed at amending relevant school rules touching on the school uniform so as to provide for exemptions to accommodate those with different religious beliefs.

In *Seventh Day Adventist Church (East Africa) v. Minister for Education & 2 Others*¹⁶³ the petitioner moved to court alleging a violation of the right to freedom of religion as provided under Article 32 of the Constitution of Kenya for students who profess the Seventh Day Adventist faith. The petitioner alleged that public schools in a variety of ways sought to restrict and curtail the opportunities available for SDA students including denying them hours of worship from Sunset on Friday to Sunset on Saturday.

The petitioner submitted that Alliance High school, Pangani Girls, Siakago Girls, Precious Blood Riruta and Kagumo High were notorious for administering examinations on Saturdays, which the SDA considered their day of rest thus expecting exemption from both manual and academic work. The court held that programs run by the Ministry of Education in the said schools are not discriminatory as they are applicable to all students from diverse religious beliefs. In essence, the court was restating the overall role of the M.o.E in management of schools.

3.9.1.4 Responsibility of Government under the Basic Education Act

The Government has an obligation to provide free and compulsory education.¹⁶⁴ Whereas the concept of free education has been effected in provision of primary education, at the secondary level, the concept seems to imply affordable education. The government, through relevant institutions ensures compulsory admission and attendance of children who have attained the school

¹⁶³ In The High Court of Kenya at Nairobi. Constitutional and Human Rights Division, Petition Number 431 of 2012.

¹⁶⁴ Basic Education Act, Section 39(a) as read with Article 53 of the Constitution of Kenya, 2010.

going age, elimination of all forms of discrimination amongst school going children, provision of adequate teaching and non-teaching staff and monitor functioning of schools.¹⁶⁵ In discharge of the foregoing duty, heads of schools are answerable to the Ministry of Education.

Provision of teaching staff is to be understood to mean facilitation through allocation of sufficient funds to the TSC to enable it carry out its constitutional mandate. However, the Boards of Management have been employing teachers on contract terms and paid by B.O.M to cover the shortfall. Such teachers are answerable to the Boards of management and are sourced through competitive recruitment or single sourcing by the heads of institutions in consultation with heads of departments. In provision of basic education, heads of institutions have a duty to investigate circumstances of the Children's absence from school.¹⁶⁶

3.9.1.5 Children Act, No. 8 of 2001

The Children Act was passed by parliament to domesticate the Convention on the Rights of a Child. The Act provides for the safeguards and rights of the child, parental responsibility, and administration of children services, children's institutions, guardianship, foster placement and adoption. It provides that every child is entitled to education, the provision of which shall be the responsibility of government.¹⁶⁷ Government institutions responsible for governance of schools and teachers are to discharge their duties having in mind the provisions of the Children Act of 2001.

3.9.1.6 Basic Education Regulations, LN No. 39 of 2015

Basic Education Regulations were published by the Cabinet Secretary of Education pursuant to Section 95 of the Basic Education Act 2013. The regulations seek to operationalize the Boards of

¹⁶⁵ Ibid, Section 39.

¹⁶⁶ Ibid, Section 40.

¹⁶⁷ Children Act 2001, Section 7.

Management and provide for the procedure of registrations of institutions. The Regulations have set the minimum age of admission into a primary school to be six years.¹⁶⁸ Under the Regulations, all persons deployed to teach in institutions of basic learning must have attended a training approved or recognised by the Cabinet Secretary and registered by the Teachers Service Commission.¹⁶⁹

It is an offence to teach in any institution if one is not registered with the commission. Registration with TSC presupposes that one has taken a course approved or recognised by the Cabinet Secretary. A challenge is with the management of the teachers employed by the Boards. First, there is no regular scheme of service across Boards. Boards employ according to their capacity and payments are dependent on the availability of funds.

3.10 Institutional Framework for Management of Public Schools.

There are various institutions responsible for management of public schools under the Kenyan legal system. They include; Ministry of Education, National Education Board, County Education Boards, County Directors of Education, Sub- County Directors of Education, Boards of Management and the Heads of Institutions.

3.10.1 Ministry of Education.

The Ministry of Education derives its mandate from Article 53 of the Constitution of Kenya 2010. The Ministry under a Cabinet Secretary who is in charge of the Ministry affairs and two Principal Secretaries. The Cabinet Secretary is directly responsible for the governance and management of public schools, management of continuing education, Administration of early childhood

¹⁶⁸ Basic Education Regulations 2015, Reg. 47(1).

¹⁶⁹ Ibid, Reg. 49.

education, maintenance of education standards, Management of education standards, curriculum development and quality assurance. To achieve its mandate, the Ministry has various directorates.

The Act provides for the Office of the Director General of Education who is appointed through an open and competitive process under the Public Service Commission Act in consultation with the Cabinet Secretary.¹⁷⁰ The Director General is responsible to the Principal Secretary and his or her powers are defined by written law and directions of the CS.

3.10.2 National Education Board.

Basic Education Act 2013 establishes the National Education Board as an advisory organ.¹⁷¹ The Board is to advise the Cabinet Secretary, the department of Education, and other government departments on matters relating to promotion of standards in basic education institutions, removal of barriers to quality education, development of measures to facilitate attendance of schools by all learners and initiation of guidelines to regulate registration of schools.

The Board consists of a chairperson and eight other members appointed by the Cabinet Secretary. The eight appointees are selected by a panel which includes representatives of schools heads associations, a representative of the Cabinet Secretary, representation from public service commission, one person representing National Council for persons with disabilities, three persons representing religious bodies, a representative of Kenya private sector alliance, a representative from TSC, trade unions of teachers, association of parents and a person representing organisations dealing with child rights.¹⁷² The Board is required to present annual report on Education to the

¹⁷⁰Section 54(3).

¹⁷¹Basic Education Act 2013, Section 5(1).

¹⁷² Ibid, Section 10.

Cabinet Secretary.¹⁷³ The Cabinet secretary may however, require a report from NEB on any matter at any time.

3.10.3 Education Standards and Quality Assurance Council

The Basic Education Act establishes the Education Standards and Quality Assurance Council with responsibilities of ensuring standards and quality in institutions of basic learning, administration of policies and guidelines set for basic education, supervision of curriculum implementation and treasury and evaluation of standards in basic education.¹⁷⁴ The Council is required to appoint quality assurance and standards officers for the purposes of effective discharge of their mandate. There is lack of clear legal framework on how the Quality assurance department at the ministry is to effectively work with the Department of quality assurance at TSC.

3.10.4 County Education Boards

The Basic Education Act establishes County Education Boards as agents of the National Education Boards.¹⁷⁵ The CEBs in consultation with county governments are to oversee management of youth polytechnics, coordinate and monitor education training in the county, interpret national policy on education based on the county needs, initiate proposals for policy reforms, collaborate with Boards of Management and heads of institution in the management of basic schools, monitor curriculum implementation and to collaborate with TSC on teacher management within the county.¹⁷⁶

County Education Board is a creation of the National government. It cannot therefore purport to be in-charge of pre-primary education and youth polytechnics, beyond policy formulation and implementation, since these two functions are devolved. The Act does not state the extent of

¹⁷³ Ibid, Section 15.

¹⁷⁴ Ibid, Section 64

¹⁷⁵ Ibid, Section 17.

¹⁷⁶ Ibid, Section 18.

collaboration between the County Education Boards and TSC. The Chairperson and twelve other members of the County Education Board are appointed by the Cabinet Secretary through an open and competitive process.¹⁷⁷ County Director of Education is the Secretary to the County Education Board. CEB may establish specialised sub-committees that are sector specific to enable it discharge its objectives.

3.10.5 County Director of Education

County Director of Education is an employee of the Ministry and is competitively recruited. The CDE is subject to the authority of the Cabinet Secretary and in consultation with the county Government implements the education policies, coordinates the supervision of education officers and support staff at the county level, manages basic education at county level, initiates education policies at county level, maintenance of quality assurance and standards in the county, advises county education board on selection and appointment of Boards of management, and supervision of handing and taking over of schools in consultation with TSC.¹⁷⁸

In performance of his duties under the Act, the County Director is required to have due regard to teacher management functions as provided for under Article 237 of the Constitution of Kenya and the Teachers Service Commission Act of 2013.¹⁷⁹ The Provincial Directors of Education, under the old constitution had dual roles of teacher management and governance of schools at the provincial levels.

3.10.6 Boards of Management

Boards of Management of institutions are composed of six persons elected to represent the parents of the pupils in the school or the local community, a representative of the county education board,

¹⁷⁷ Ibid, Section 20.

¹⁷⁸ Ibid, Section 54 (7).

¹⁷⁹ Ibid, Section 54 (8).

a representative of the teaching staff within the school, three persons representing the sponsor, a person representing special interest persons in the community and a representative of persons with special needs.¹⁸⁰

The Board may co-opt not more than three persons who possess skills and experience to help in discharge of the Boards mandate.¹⁸¹ Members of the Board are to elect their chairperson with the exception of schools sponsored by faith based organisations whose chairpersons are appointed by the County Education Board in consultation with the sponsors.¹⁸²

B.o.Ms are established to promote the best interests of institutions, promote quality education, manage institutions affairs, advise the County Education Boards on the staffing needs of the institution, report on areas of their mandate to the County Education Board, encourage culture of dialogue and participatory governance in schools, encourage stakeholders to render voluntary services to the institutions, administer and manage resources of the institution and recruit non-teaching staff.

3.10.7 Heads of Institutions as Agents of the Ministry in Governance of Schools

The Head of an institution is in-charge of day to day running of an institution of basic learning.¹⁸³ In addition, the head teacher is the accounting officer of the institution, an authority delegated by the Cabinet Secretary.¹⁸⁴ Even though the CS delegates the authority to the head of an institution, he is not involved in the process of appointment and has no express authority over the head of an institution.

¹⁸⁰ Ibid, Section 56(1).

¹⁸¹ Ibid, Section 56(2).

¹⁸² Ibid, Section 56 (5).

¹⁸³ Basic Education Regulations 2015, Reg. 5 (1).

¹⁸⁴ Ibid, Regulation 5(2) a.

In the event of impropriety, the CS can explore disciplinary mechanisms contemplated under the TSC structure. As the Secretary to the Board of Management, the head of an institution is at the centre of the implementation of the ministry’s policies and programs. If impropriety is proved against a head of an institution, the CS is to revoke the designation of such a head as the accounting officer and request TSC to make a replacement. The ambiguity in this provision is that it purports to give directions to TSC regarding the appointments of principals. There are instances when the CS has made pronouncements against particular heads of institutions only to be dismissed by TSC for lack of jurisdiction.

Figure J: The administrative structure of institutions of basic education in under the Kenyan legal system.

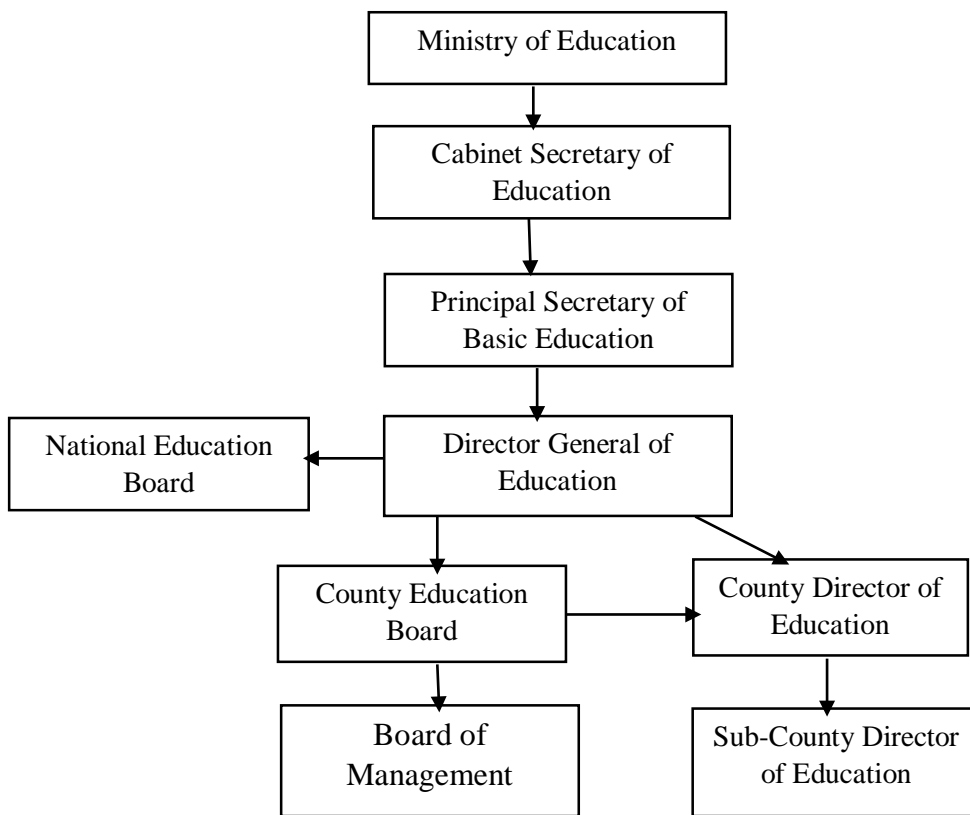

Source: Author

3.11 Conclusion

The Constitution of Kenya 2010 has facilitated enactment of new legislations and creation of institutions to give effect to the right of every child to access free and compulsory basic education and operationalize TSC. In so doing, the enabling laws have brought about duplicity of roles because certain institutions created by both the Basic Education Act 2013 and TSC Act 2012 create institutions with similar functions. Subsequently, the discharge of these functions has resulted to various tensions between TSC and MOE.

Teachers Service Commission Act 2012 gives effect to Article 237 of the Constitution of Kenya 2010 with respect to the organizational structures and functions of the TSC. The Act fails to provide for the role of MOE in teacher management thus creating ground for conflict between TSC and MOE in discharge of their duties. Since the Ministry is in charge of policy formulation, it works closely with the policy implementers who are teachers without a clear legal framework.

Basic Education Act, 2012 is enacted to give effect to Article 53 of the Constitution of Kenya 2010. The Act clearly outlines the role of the Ministry of Education in governance of schools but fails to mention the extent of Ministry's involvement in teacher management. This chapter has therefore reviewed the existing legal and institutional framework with regard to teacher management and governance of public schools.

CHAPTER FOUR

FIELD STUDY OF KAKAMEGA COUNTY RELATING TO TENSIONS BETWEEN TEACHERS SERVICE COMMISSION AND MINISTRY OF EDUCATION

4.0 Introduction

The chapter provides a case study of Kakamega County in relation to tensions between the Teachers Service Commission and the Ministry of Education. The choice of Kakamega County is informed by the fact that it is the largest county in Kenya in terms of population. Its cosmopolitan nature offers diverse experience. It has about 938 public primary schools and 276 public secondary schools.¹⁸⁵

The chapter seeks to interrogate the efficacy of the Basic Education Act, 2013 and Teachers Service Commission Act, 2012 in demarcating the role of MOE and its agents in teacher management and tensions brought about by failure to provide a legal framework of engagement between TSC and MoE in teacher management and governance of schools. The first part sets out research design whereas the second part outlines data collection tools. Part three and four enumerates and analyses the responses from respondents. The last parts lists and discusses various tensions existing between TSC and MoE.

4.1 Research Design

This study adopted a case study approach. It entailed an in-depth study of teacher management and governance of public schools which broadly comprised three stages. The first stage entailed identification of key informants. This stage was useful in that it enabled the researcher to obtain first-hand information. The second stage was data collection while the third stage involved data

¹⁸⁵ This information was given by the County Director of Education, relying on returns filed by Sub-County Directors of Education in the county on 10th May, 2018 at 1500 hrs.

analysis. The use of this design enables the researcher to get first-hand information which is reliable.

4.2 Data Collection

The first stage involved the creation of an interview schedule.¹⁸⁶ The interview schedule contained questions geared towards identifying various tensions existing between TSC and MOE with respect to teacher management and governance of schools, how the history of teacher management contributes to the tensions and remedial measures. The data collection process entailed the interviewing of one County Director of Education, one TSC County Director, twelve Sub-county Directors of Education, twelve TSC Sub-County Directors, twelve Heads of Public Primary Schools, twelve Principals of Public Secondary Schools, twelve Chairpersons of Boards of Management, four Diocesan Secretaries of Education and twelve teachers employed by Boards of Management.

The interview schedule was informed by the key objective of the study which was to determine whether there is any tension between TSC and MOE occasioned by conflict of their roles. The interview schedule consisted of two sections. The first section comprised general questions to be answered by all respondents while the second section was exclusively meant for the county and sub-county Directors

Arrangements were made to help secure prior informed consent. In securing appointments, respondents were able to allocate reasonable time to the interview. Respondents chose to use pseudo-names whereas in other cases, they refused to fill names section but nonetheless consented

¹⁸⁶ Appendix 1

to the interview by appending their signatures on the schedule. Having the consent of the respondent is part of research ethics.

4.3 Data Analysis

The collected data was analyzed using content analysis which is a systematic qualitative description of the responses. This analysis is used to summarize any form of content. The importance of content analysis is that it focuses on themes. The following section will discuss the following themes; Role of TSC, Tensions between TSC and MOE, Boards of Management, Management of funds, Relationship between TSC and MOE, responses from MOE, quality assurance and maintenance of standards, Rivalry between the TSC and MOE, Independence of Commissions, Governance of schools and Representation from sponsors.

4.4 Role of Teachers Service Commission

This section captures content analysis of responses from the TSC county director and 6 sub-county directors in performance of their role, existence of tension, the cause of tension, if any and the genesis. The county director as well as sub-county directors chose to use pseudo names. The mention of county director and sub-county refers to their designations.

The TSC county director observed that the new legal regime has made collaboration between TSC and MoE more sufficient. She stated that her role as an agent of the commission was restricted to teacher management and quality assurance. When asked about what she meant by quality assurance, she observed TSC engages in quality assurance through monitoring of the curriculum. She stated that even though the laws were very clear, there existed tension between the Ministry of Education and TSC. She stated that in 2012, the tension was high but each side is now settling down to their respective roles. This assertion was equally shared by the sub-county directors who confessed that they were not in talking terms with their MoE. Counterparts at the early stages of

their inception. Both the TSC County Director and sub-county directors said that where duties of TSC and MoE overlap, it is hard for MoE to let TSC lead. Asked why, their response was unanimous that because Ministry is viewed as government, the bureaucratic procedures required in the discharge of overlapping roles are likely to favor them. An example of this is where there are funds to be released for capacity building for teachers, a responsibility to be exercised by both TSC and MOE, the ministry is likely to have their request cleared by relevant authorities. This shows that when the Ministry gets an opportunity to flex its muscles, it does so to the detriment of TSC.

4.4.1 Tension between TSC and MOE

The TSC County Director noted that there was tension between the commission and the Ministry. He listed the areas of tension to include quality assurance and maintenance of standards in schools, role of heads of schools as lead educators and agents of the Ministry in governance of schools, duplicity of structures, roles of Boards of Management and involvement of sponsor in teacher management and governance of schools.

TSC County Director stated that MoE has never come to terms with the fact that TSC is an independent commission. It was their position that MoE official still wants to discharge their duties as though they are working in the past when TSC used to be a semi-autonomous unit at the ministry. It was the Director's contention that the Ministry is desirous of encroaching on their constitutional mandate of TSC.

TSC Sub-county Director observed that even though the Ministry contends that they have the sole responsibility of ensuring that quality and standards are maintained, they had (as agents of the commission) lawful authority to perform functions related to quality assurance. The Director said that even though the curriculum is developed by the Ministry, its supervision is by the commission

because it is implemented by TSC employees who are the teachers. To TSC respondents, any attempt by the Ministry to supervise the implementations of the curriculum would amount to interference with teacher management since it will require MoE to supervise the teachers, an authority vested in the Commission. The county director noted that governance of schools is not an exclusive mandate of the Ministry. To her, management of institution concerns TSC in so far as Teacher performance and appraisal as well as performance contracting for heads of institutions are concerned. She provided an example of a boarding school with a boarding master who is an employee of TSC and subject to the rules of Teachers Service Commission. To effectively ensure the boarding master discharges his duty effectively, TSC's intervention is key. The director reiterated that the Ministry has no effective mechanism to supervise the boarding masters. In case of discipline, the director said, it is only TSC which can act under both the Constitution and the TSC Act.

4.4.1.1 Boards of Management

The TSC County Director recognized that TSC is not part of the Boards of Management. However, the commission is represented by the head of institution who is the secretary to the Board. TSC Sub-county directors held the view that there is nothing wrong with their attending board meetings as teacher management issues keep on propping up during Board meetings. They stated that TSC has delegated authority to the Board in a number of ways. First, they the board initiates disciplinary action and may interdict a teacher. Second, during recruitment, the board interviews and selects candidates on behalf of the Ministry. They therefore contended that there is no problem with TSC agents working closely with Boards of Management for effective management of schools.

4.4.1.2 Management of funds

Another source of tension between TSC and MoE, sub-county directors contended, related to the management of funds. They observed that indeed under the Basic Education Act, principals and head teachers are accounting officers of their respective schools, an authority delegated to them by the Cabinet Secretary. Respondents said that such a provision opens an avenue for interference with principals in discharge of their functions. They said principals require some sense of authority in running of financial affairs of the school. They observed that the ministry had used the provision to frustrate teacher management related functions. In a certain school within the county, the sub-county director of Education restricted the transaction on school account on grounds that an audit done by the Ministry of Education had established impropriety on the part of the head teacher. For three months, they had to look for the said sub-county director in order to have expenditure approved. TSC county director also stated that the decision to return funds meant for purchase of text books under the purview of the Ministry of Education is ill-advised. In their words, MOE is acting idle. They contended that it is teachers who know the kind of books required by learners. Sub county directors reported that there are already complaints from teachers to the effect that the text books supplied by the Ministry are substandard hence posing a danger to the effective implementation of the curriculum. It was clear from this interview that TSC agents feel MoE is getting too much involved in teacher management.

4.4.2 Relationship between Ministry of Education and Teachers Service Commission.

The County Director of Education observed that on face value, there exists cordial relationship between TSC and MoE but underneath, there is a vicious fight between the two stakeholders. When asked whether they always implement the requests and recommendations of MoE regarding Teacher management, TSC Director responded that they are not bound by such decisions. In

deciding whether or not to act on any report from the Ministry depends on the procedure and means used in arriving at conclusions in the report.

The County Director provided the example of a school in the county where MoE carried out an audit and purported to find the principal culpable. According to the respondents the ministry faulted the principal for diverting funds meant for infrastructural development to teacher motivation, irregular procurement of books and firewood, non-class attendance evidenced by her name missing on the master time table and in the report accused the County Director for colluding with the principal to help her get promoted. The respondent reported that TSC found the report to be defective as MoE acted ultra-vires by purporting to audit the principal on class attendance as that was purely a teacher management function. In addition, the director stated that the Ministry had no capacity to audit TSC agents in performance of their duties.

4.5 Role of Ministry of Education

Under this category of respondents, I interviewed county director of Education and the sub-county directors of Education. Their responses can be reduced into the following themes:

4.5.1 Quality assurance and maintenance of standards

The representative of the Ministry of Education at the county level maintained that it is the responsibility of the Ministry of Education to maintain quality and standards in school. The respondent used the allegory of a farmer who has asked a security firm to assign security personnel to guard his farm.

In the respondent's view, it is the responsibility of the farmer to ensure the farm is well maintained. He said the security firm has and should have nothing to do with maintaining the quality of the farm. When prompted to simplify the allegory, the respondent said the Ministry was the farm

owner, the farm was the school, teachers were the security guards and TSC was a security firm. To him, everything in school, other than teachers, belong to the Ministry. All the facilities, funds and students are the property of the ministry of education and TSC should not purport to have competence over quality assurance and maintenance of standards.

Secondly, the CDE stated that the Ministry has an elaborate structure throughout the county headed by a council established under the Education Act to be in-charge of Quality Assurance and maintenance of standards. To him, TSC has no quality assurance and standards officers save for a moribund Quality Assurance's directorate established at its headquarters. The respondent reported that anytime they go to audit school, they are always accompanied by TSC on the account that teacher management is a serious aspect of quality assurance. The respondent maintained that the Ministry has both the mandate under the law and the capacity to carry out quality assurance and maintenance of standards without any form of assistance from T.S.C.

At the sub country level, the respondents blamed the TSC official for intermeddling. They cited occasions when they have walked in Board meetings to find their TSC counterparts in attendance. Additionally, the respondents wondered why TSC officials attend school Annual General Meetings.

4.5.2 Rivalry between TSC and Ministry.

The County Director stated that there exists sibling rivalry between the Ministry of Education and the Teachers Service Commission. He noted that the roles of both the Ministry and TSC are overlapping and are not clearly defined. According to the CDE, the drafters of the Constitution are to blame for the mix up of the law. He observed, a position shared by sub county directors of education at the Ministry level, that whereas there is an entire Article dealing with the Teacher Service Commission, clearly outlining its role, the same is not to be said of the Ministry. To him,

the Ministry of Education is disadvantaged because its mandate is not clearly stipulated in the Constitution. He stated the tension between TSC and the Ministry is big and may soon reach alarming heights. Secondly, he observed that the power struggle is premised on poor understanding and interpretation of laws. He blames TSC for subjective application of law. He said TSC relies on the term independence of constitutional commission' as a basis of excluding the Ministry from the programs where the Ministry feels it should be involved. To the director, the core responsibility of TSC should be purely human resource and nothing more.

The County Director when asked why he feels there is conflict of law, he says the Teachers Service Commission Act 2012 was enacted and operationalized earlier as opposed to Basic Education Act which was operationalized in 2015. To him, TSC Act ought to have been promised on the Basic Education Act. He cited the provision of Basic Education Act which makes the head of an institution secretary to BoM. He says the rationale behind this was that at that time, the Ministry believed that they would have control over appointment and discipline of heads of institutions. He repeated his assertion that the TSC duplicates roles of the Ministry especially on quality assurance. Sub-county Directors stated that the Ministry is well equipped to complement TSC in its functions but the Commission rarely consults them. They stated that at one time, they thought of evicting the TSC officials from Ministry buildings so that they can exercise their independence from elsewhere. Apparently, I discovered that TSC is yet to acquire their field offices and are still housed at the Ministry of Education premises.

4.5.3 Independence of Commissions

On the independence of constitutional commissions, County Directors said that TSC is merely engaged in sideshows. By this he meant that TSC was invoking its constitutional status to intimidate other stakeholders. He cited the cordial relationship between the Public Service

Commission and the Ministry of Public Service, the Auditor General and the Treasury and the National Land Commission and the Ministry of Lands. To him, there exists cordial relationship between the Public Service Commission and the Ministry of Public Service because PSC Commissioners understand the law and appreciate interdependence and consultation as they maintain their distinct identity as an independent commission. The Director observed that TSC treats independence to mean exclusion of all other entities.

4.5.4 Capacity Building

According to the respondents, part of the problem why conflict exists is in capacity building. Respondents felt that TSC should have nothing to do with capacity building of teachers. To this end, they said the Kenya Institute of Curriculum Development and Kenya Education Management Institute should be exclusively managed by the Ministry of Education and be responsible for teacher development. They also said the leadership of the two institutions should be determined by the Ministry of Education.

When asked about the origin of the crisis that has occasioned the tension, the County Director gave the foundational background of the existing crisis. He stated that during the making of the Constitution of Kenya 2010, certain senior officials at the Ministry of Education conspired to and partnered with Kenya National Union of Teachers in advocating for a stronger and powerful commission. Since the officials were called upon to assist in structuring TSC, they assigned most powers to the Commission leaving the Ministry an empty shell.

4.5.5 Governance of Schools

The county director stated that it is the primary responsibility of the Ministry of Education to manage schools. He however said they have a problem executing the mandate. Similar response came from the sub-county directors. The reason they gave as a hindrance to discharge of their

duties is that they have no authority over heads of institutions who are exercising a delegated authority in school management. It was my feeling that both the County Director and Sub county Directors are feeling ignored by the heads of institutions. About five sub county directors stated that certain principals and head teachers are notorious for ignoring their calls even on urgent and important matters. When asked the reason why their subordinates would not respond to their calls, they said it is because the heads have formed a notion that the Ministry had no authority over them.

4.6 Representation from the Sponsor

The sponsor identified themselves as the church and owners of the schools. According to the sponsor, schools are theirs and should be run by them. Teachers Service Commission and the Ministry are agents of the sponsor. The sponsor raised the following issues: -

4.6.1 Appointment of Principals and Head Teachers

The sponsor recognizes the fact that TSC has the legal mandate to appoint and deploy school administrators. However, they contended that the deployment must be done in consultation with them. Asked whether consultation had to be through heads of the respective churches, they answered that the level of consultation varied with the level of the school. For the national schools, consultation on deployment of heads is to be limited between the TSC secretariat and the national leadership of the parent church. For the extra county schools, the consultation is between County Directors and the Bishops of a parent church. For the county schools, the consultation is between sub county TSC directors and local church leadership.

The reason advanced by sponsors is that they have, established a culture through which their schools are run. They argued that before mission schools were handed over to government, they were run by missionaries, who were attached to churches. This meant the school administrators professed the faith of the founding church. Such administrators would preside over a regime that in calculated

values based on the beliefs of the founding church. Rev. Father Peter (not his real name) observed that unlike in the past when Catholic Church sponsored schools would conduct morning service in schools on daily basis, it is now common to find that such institutions expose students to church service once every week. The priest stated that this is partly to blame for the rather youthful generation. Rev. Peter stated that when the church used to decide on who became the principal of a school, their schools (Meaning the Catholic Church) used to perform well.

A diocesan Secretary of Education of a popular faith in the county almost broke down while commenting on the ongoing policy of delocalization and its effect on their schools. He said TSC failed and ignored to consult them before implementing the delocalization policy. In one example, the priest, who is in charge of the education programs for catholic schools in the area of study, cited a catholic girl's school that was headed by a catholic nun. The history of the institution is that the retired Bishop was given a gift, during one of his foreign trips. The gift was a new Mercedes Benz. The bishop requested that the car be converted to cash to help raise the girl child, the bishop started a girls' school using the funds and handed it over to government. Overtime, the Catholic Church has always been consulted on its leadership. In May 2018, TSC transferred the nun and brought a non-Catholic head. The nun was taken to a place where there was no convent. The priest said that in the culture of the Catholic Church, nuns cannot rent houses and can only be accommodated in the convent. The priest accused TSC for acting irresponsibly by failing to consult the church on leadership of the said school and secondly, for exposing their nun, a trained teacher qualified to be a principal and in fact, acting as one to an area where she could not get a covenant. He called it 'hostile' environment. The priest further said that the church was not opposed to having heads who do not profess the Catholic faith head catholic sponsored schools, but the church was simply asking for recognition in the process of deployment. He cited several

schools within the county which are sponsored by the Catholic Church but headed by non-Catholics.

In the county, I found that there exist certain schools which on the face of it, look like private schools sponsored by the Catholic Church, yet they are public schools run by the Ministry of Education and their teachers are deployed by, and subject to TSC. In practice, these schools are in essence run by the church. They include St. Anne's Girls' Primary School, St Mary's Mukumu Girls' Primary School and St Peters Mumias Boys' Primary School. These schools are either girls and boys, boarding and day, and are run by Catholic Church nuns. The Boards of Management are appointed by the Ministry in consultation with the church and their heads since inception, have been catholic nuns except once. Performance of these schools has constantly remained impressive, outshining private schools in the county. When I asked the diocesan secretary of education whether the church would accept any head teacher transferred to the school under the policy of delocalization. His response was that it would be unacceptable and that TSC should only deal with other teachers, including Deputy Head teachers as the church retains power on who to appoint a head teacher.

4.6.2 School Land Title Deeds

The Catholic and Anglican churches reiterated that as the founders of the mission schools that were handed over to governments, they retain school ownership. Sponsors stated that they bought land and developed the schools. Based on the field study, my findings are that the mainstream churches, the Catholic Church, the Anglican Church, Islam, Friends Quakers Mission and Methodist church bought land, developed schools and handed them over to the government. The mainstream churches that sponsor schools in Kakamega County are the Catholic Church, Friends Quakers and the Anglican church of Kenya.

The Catholic Church acquired 65 acres of land and developed a boys' secondary school in 1956 which they later handed it over to government. The buildings constructed in the school by the missionaries are still being used. At the entrance of the school, there is a chapel, which according to the sponsor is a symbol of ownership. The Diocesan secretary of education mentioned several other schools whose land was acquired by the church and structures developed by both the church and the government. He stated that from 2010, the government has put pressure on churches to transfer titles to the names of individual schools. At one school in Kakamega County, the church has been farming on a 20-acre piece of land. The Ministry, through the Board of Management has asked the church to vacate. Respondents (sponsor) observed that transferring the title would amount to ceding possession of schools.

4.6.3 Religious Practices

Respondents in this section contended that it is the primary responsibility of the sponsor to ensure that the tradition of the schools is maintained. To the sponsor, tradition means religious practices in the school. I visited school X, a Muslim boarding and day school where the sponsor stated that even though Christian students are not compelled to wear hijab, they are advised to cover their faces. In the institution, other denominations have not been provided with space to conduct their prayers. At school Y, a boy's catholic school, the sponsor had no problem with other denominations practicing their faith, only insisting that the official religious practices in the school would be those of the Catholic Church.

4.7 Responses from Board of Management

This section contains responses from Boards of Management with regard to their role as managers of schools. Chairpersons of the Boards, in this section also refer to their representatives. Responses from Board of Management can be divided into three sections. They include, role in

teacher management, role in governance of schools and problems facing the Boards in discharge of their duties.

4.7.1 Role of Boards in teacher management

The respondent said that they have always been called to address issues related to teacher management. A respondent who had the opportunity of serving as chairperson of different schools for a cumulative period of 30 years stated that throughout his tenure as chair, he has presided over interdiction of about thirteen teachers. He stated that he had been involved in matters relating to teacher discipline that he no longer needs to refer to the Code of Conduct when disciplining a teacher. Respondent P, who has served as chair of a Board for eight years observed that they (together with Board members) work as agents of the Commission to monitor teachers. Majority of the respondents said for them to succeed in discharge of their duties, they have to closely work with the principal of the schools.

A respondent Y, who was representing the chair in a certain school within the county said Boards are merely extensions of the principal's office. Asked what she meant, she explained that during Board meetings, it is the principal who runs the show while other members are used as puppets to rubber stamp what the principal wants. Probed on their independence as Board members, she said certain principals have developed divide and rule tactics and in some extreme situations only invite compliant members to the meeting. Respondent P said that because they are on ground, they understand the teachers more than both the ministry and the commission and therefore should be allowed to help in teacher management.

My finding is that Boards of Management consider themselves part of teacher management even though most respondents did not understand the boundary between teacher management and governance of schools. They had no idea about demarcation of roles between the Ministry of

Education and the Teachers Service Commission. When asked who they thought they were answerable to, eight of the respondents said they were answerable to the principal, one said she was answerable to the Teachers Service Commission, one said he was answerable to the sponsor while two said they were answerable to the Cabinet Secretary for Education. On the question whether they have realized any change between 2010 and now, 9 of the 12 respondents said they had seen none while 3 said they are no longer summoned by District Education Officers (present day sub-country directors) as it used to be in the past.

4.7.2 Roles of Boards in governance of schools

All respondents said that they have been trusted with the management of schools by government. Asked what constitutes their role as managers, they said their primary roles were ensuring the principals and parents work in unison, peaceful co-existence between teachers and non-teaching staff, recruitment of non-teaching staff and their discipline as well as discipline of students. They also said they are in-charge of finances and infrastructure in schools.

Asked whether they are always available in schools for both meeting and routine visits, they said they have an executive board of fewer members who can be summoned to a meeting on short notice. Once the executive board has taken a position on a matter that required urgency in solving, such a matter is brought before the full Board for ratification. On finances, the respondents said they have a duty to ensure prudent expenditure of school finances. They also source for finances from donors and local leadership through Constituency Development Fund.

4.8 Relationship between Boards of Management and Principals

Asked whether they had any problems in discharging their functions, the respondents dwelt on the treatment they receive from the principals. Respondent Y stated that they rely on principal for guidance on how to discharge their duties. She stated that before taking a position on any matter,

she first must consult with the principal to know her position. She recalls an instance when she advanced a contrary argument from what the principal had suggested. For the next three subsequent meetings, the principal convened the Board meetings through the vice chairperson and the chair learnt of it late and could not make it for the meeting. Three respondents, X, Y and Z complained that at times, they are brought checks to sign without understanding the nature of the transaction for which the funds are being withdrawn. Asked why they cannot refuse to sign, they responded that it would strain their relationship with the principal and be treated as sabotage.

Asked on the scope of agency relationship between them and the Teachers Service Commission, they responded that indeed they perform quite a number of functions for the TSC. On whether there is any difference in the manner in which they perform their duties before and after 2010, they were all in agreement that there is a great change. They observed that previously, the decision of Boards was binding unlike presently when the decisions can be changed by TSC. Respondent X gave an example of the school where she chairs the Board. In her case, TSC asked her to convene a meeting for the purposes of disciplining a teacher who had administered corporal punishment to a learner, contrary to the Children's Act and Teachers Code of Conduct and Regulations. The respondent convened the meeting, heard the parties concerned and decided to issue the teacher with a warning letter, which according to them, is a form of punishment provided by the law. A representative of the TSC was present during the meeting and kept on urging members to interdict the teacher.

The Board stood its ground and proceeded to issue the teacher with a warning letter. After a week, in a letter addressed to the principal and copied to the respondent, the County Director (TSC) observed that the Commission was dissatisfied with the decision of the Board and had thus convened another disciplinary meeting for the concerned teacher at the county headquarters. The

respondent observed that disregard for Board decisions by TSC beats the logic of having Boards exercise delegated authority on behalf of the Commission. Other occasions of content, according to respondent P, regards the appointment of sub-ordinate staff. The respondent observed that even though the employees are referred to as ‘B.o.M employees’ in practice, Boards are never involved. The principals, in certain cases solely hire the staff. The Board is only involved where a sacked employee moves to court to seek legal recourse.

Respondents said that even though they are aware that they should be notified of a meeting at least fourteen days before the meeting date, in practice that was not the case. Respondent Q stated that on many occasions, the principal has always notified him of meeting dates when in essence, meetings should be convened by the chair in consultation with the principals.

4.9 Responses from Heads of Institutions

This section includes the responses from heads of Institutions both as Lead educators and administrators as well as agents of the ministry in governance of schools.

4.9.1 Heads as lead educators and administrators

Respondents stated that their primary responsibility in schools is to teach. Leadership positions find them in the teaching profession. As lead educators, they said they act as agents of TSC on teacher management and are primarily responsible to and answerable to the Teachers Service Commission. In fact, Respondent P, a chief principal at a school in the county said they no longer refer to Teachers Service Commission by the name; rather they simply refer to TSC as “Employer”. To the respondent, the employer is Supreme and incomparable to any other entity involved in teacher related functions.

Respondent Z, stated that where correspondence from both the ministry and TSC contradict, the decision of the Commission takes precedent over that of the Ministry.

Asked whether there is any problem they experience in the course of discharging their duties, Respondents noted quite a number of challenges. First, they have borne the brunt of sibling rivalry between the Teachers Service Commission and the Ministry of Education. Respondent D stated that at a prize giving function, she was unable to deal with the issues of protocol. In attendance were TSC County Directors as well as her Ministry of Education counterpart. Each of them through a text message, requested the Principal to invite her last. This forced the principal to move away from the function until the Master of Ceremony solved the issue.

Eventually, the TSC County Director of Education carried the day, to the chagrin of the Ministry of Education County Director. Mrs. M, Principal of a school within the county said she had received instruction from sub-county Director of Education (Ministry) that she should not be inviting the TSC sub-county Directors for the Board Meetings. The same Principal was also called by TSC sub-county Director to submit a schedule of Board meetings for term two. Caught in a fix, the Respondent decided to serve both with schedule of meetings. She further said that during Board meetings, whenever the Ministry officials are represented, the TSC officials do not turn up unless it is a matter touching on teachers.

4.9.2 Governance of Schools

Respondents acknowledged that indeed it is the responsibility of the government, through Ministry of Education to run public schools. They acknowledged that in the running of schools, they have the primary duty of financial management, management of school's physical resources, student management and correspondences with Ministry of Education. They however noted a few problems associated with Boards of Management. Respondent M stated that her chair of Board is

a retired officer who served as a District Education Officer under the old system. According to the Respondent, the chair wants to drive the Board agent under the repealed statutes.

For instance, the chair at one time insisted that the Principal directs County Director for Education (Ministry) to transfer a teacher who had refused to take students to church. The chair was a staunch Catholic who had been seconded to the Board by the church. In essence, the Chair thought the Ministry of Education still yielded immense powers over teachers and that a teacher could be sacked on phone.

Another obstacle that the respondent noted under the current legal regime governing education is interference from the sponsor. Respondent X cited instances when the church had attempted to interfere with running of schools.

First, the Respondent said that in church sponsored schools, sponsor wanted to be informed of every program and wanted to determine which teacher to be given what role and who to employ as non-teaching staff in school. Mr. X said he was once served with a list of persons from a local church leader with instructions to have the persons employed. In certain school, the Bishop of the sponsoring church insisted that he must become the Chair of the Board. The Principal resisted the move arguing that as a Bishop, he was best placed to stand as an arbiter incase the Board and the Principal had a problem. Eventually, the Bishop had his way and became the Chair of the Board. The relationship between the Chair and the Principal were so strained that the Principal had to be transferred.

4.10 Boards of Management Teachers

Sub-County Director of Education A stated that there is a group of teachers teaching in public schools in Kenya referred to as BoM teachers. According to the Respondents, these are teachers

who are registered by the Commission but have not been entered into roll of employed teachers but have been retained by Boards of Institutions to fill the teacher shortage in schools.

I interviewed ten teachers employed by the BoM and established that even though they are said to have been employed by the Boards of Management, some never get to sign contracts. One respondent was simply invited by the Principal and assigned classes to teach. The other respondent was questioned by an uncle, who sits on the Board to go see the Principal. When the respondent arrived in school, she was asked to report back the next day ready to commence teaching. The two respondents are subject to the rules governing other teachers and are not exempted from any duties assigned to teachers employed by the Commission.

4.11 Findings

The respondents from Teachers Service Commission and the Ministry of Education agree that teacher management is a function of TSC. However, the Ministry maintains that by allocating teacher functions to the Commission, the Constitution did not seek to oust other stakeholders in teacher management. The Ministry further holds that it retains the overall policy formulation role with regard to teacher management views the commission as a human resource unit with limited functions. The County Director of Education stated that the Ministry should be consulted on deployment of heads of institutions since governance of schools is the primary function of the Ministry of Education.

All respondents agree that the Ministry is primarily responsible for governance of schools. The sponsors feel that they are key stakeholders and as such, have a crucial role to play in governance of schools. The sponsors opine that they should be consulted in the deployment of heads of institutions as heads play a crucial role in the management of public schools.

The Ministry of Education is constrained by the current legal framework governing teacher management and governance of public schools. Nature of constraints are that the heads of institutions who act as agents of the Cabinet Secretary as accounting officers of their institutions are answerable to TSC. The ministry cannot effectively oversight the heads as there exists no legal framework for such engagement. The Basic Education Regulations provide that where an impropriety is established on the part of the head of an institution, the Cabinet Secretary shall request TSC to make a replacement.

Sponsors are not fully involved in teacher management and governance of schools. Education secretaries of mainstream churches within Kakamega County are of the opinion that they should be consulted on teacher management and governance issues.

Boards of Management are prone to manipulation of by heads of institutions. As secretaries to the Boards, the heads set the agenda for board meetings and push it through the meetings. The Heads of institutions are not answerable to the boards and therefore can sabotage the board without suffering any repercussions. \

Heads of institutions are at the center of power struggles between TSC and MoE. Areas of tension revolve around administration of funds. The Ministry of Education wants to decide persons to run public schools, transfer and discipline heads of institutions without making reference to TSC. Teachers Service Commission on the other hand maintain that any administrative engagement between teachers and MoE must be done within the confines of Article 237 of the Constitution.

4.12 Conclusion

Through a case study of Kakamega County, this chapter demonstrates that there is in fact a power struggle between TSC and MoE in discharge of their duties. This tension is characterized by existence of similar structures between TSC and MoE with regards to Quality Assurance and

maintenance of standards, involvement of head teachers and principals in governance of schools to the exclusion of other stakeholders such as sponsors in teacher management. Even though the Sponsors are outside the TSC and MoE nexus, they have historically been consulted on teacher management. The chapter concludes with some reflections on the findings, derived from the content analysis of the interviews.

CHAPTER FIVE

CONCLUSION AND RECOMMENDATIONS

5.0 Conclusion

This study set out to examine the tensions between Teachers Service Commission and the Ministry of Education in teacher management and governance of schools under the Kenya's post 2010 legal system.

In understanding the tensions, the study reviewed the history of teacher management and governance of public schools, examined gaps in existing legal and policy framework on teacher management and governance of public schools in Kenya and identified tensions existing between the Ministry of Education and Teachers Service Commission in teacher management and governance of schools using a case study of Kakamega county.

The study was premised on the hypothesis that failure by Teachers Service Commission Act, 2012 and the Basic Education Act, 2013 to provide for a legal framework of engagement between TSC and MoE is the root cause of tensions between the two entities in discharge of their duties. even though the Constitution of Kenya 2010 provides for the roles of Teachers Service Commission, it fails to make mention of the functions of Ministry of Education hence creating recipe of conflict between the two entities in discharge of their functions because teacher related functions have always been a preserve of the MoE.

This study developed this argument by situating the conflict within a historical context. It argued that the existing tensions between TSC and MoE arise from the fact that until 2010, TSC discharged its teacher management functions in consultation with and at the direction of Ministry of Education.

Guided by sociological school of thought and critical legal studies, the study undertook a historical review of teacher management and governance of schools, critically analyzed the legislative and institutional framework for teacher management and governance of schools and carried out a field study of Kakamega County in order to prove the hypothesis. The case study of Kakamega proved the hypothesis by establishing through respondents that there is no legal framework of engagement between TSC and MoE on teacher management and governance of schools.

The existence of similar structures such as Directorate of Quality Assurance and Standards, County Directors and Sub-county Directors has brought about duplication of roles leading to tensions between TSC and MoE.

5.2 Key Areas of Tension between TSC and MOE

From the case study of Kakamega County, the tensions between TSC and MoE appear to have drawn in other stakeholders with heads of institution torn between being answerable to the commission and the Ministry. The areas of conflict between TSC and MoE revolve around the following thematic areas;

5.2.1 Teacher Management

The study examined the history of teacher management as well as the legal instruments governing it. Since the creation of Education Department in 1911, teachers have been directly managed by government through the relevant Ministry. The creation of Teachers Service Commission in 1967 did not exclude the Ministry from teacher Management. Teachers Service Commission basically existed as a semi-autonomous unit within the Ministry of Education. The promulgation of the Constitution of Kenya 2010 elevated Teachers Service Commission to an independent Commission and vested it with the exclusive mandate of teacher management.

The main problem between Teachers Service Commission and the Ministry of Education is grounded in the fact that Ministry of Education has never come to terms with the new legal developments with regard to teacher management. The study established that key Ministry officials were involved in the structuring of Teachers Service Commission during the Constitution making process. Since most of the officials were interested in occupying strategic position in the new Commission, they created a powerful Commission and weakened the powers of the Ministry with regard to teacher Management. Unfortunately, the Commission did not accommodate all the interested parties. It is the persons who had set their eyes on positions of Commissioners, County Directors and Sub-county Directors that are finding it difficult to adapt to the new system hence encroaching on the roles that are exclusively reserved for the Commission.¹⁸⁷

The study also established that the interpretation of the constitutional and statutory provisions with regard to teacher management is a source of conflict. Teachers Service Commission has acted independently even where it ought to have consulted the Ministry. Teachers Service Commission has interpreted the meaning of independent Commission to mean exclusion of others stakeholders. The practice continues to drive a wedge between Teachers Service Commission and Ministry of Education. There are several instances when Teachers Service Commission has refused to act on the recommendations of the Ministry, even where such recommendations are in the interest of prudent management of school resources.

5.2.2 Governance of Schools

The study established that the current legal regime gives the Ministry of Education exclusive powers over governance of public schools. However, these powers are constrained by the fact that head teachers and principals, who are the agents of the Cabinet Secretary as accounting officers of

¹⁸⁷ As stated by the County Director of Education during Field study IN May 2018.

their schools, are not answerable to the Ministry of Education. In essence, the government has no autonomy when dealing with principals and head teachers of public schools. Secondly, the Basic Education Act 2013 provides that heads of institutions shall be the secretaries to their respective Boards of Management yet these heads are not answerable to the Boards. The Boards of Management can easily be held hostage by heads who do not believe in the rule of law

5.2.3 Sponsors

In teacher management and governance of schools, the role of the sponsor cannot be gainsaid. The study established that the Basic Education Act gives a vague definition of the sponsor and fails to allocate the sponsoring Church specific roles in teacher management and governance of schools. Under section 2 of the Act, the sponsor is defined as a person or an institution who makes a significant contribution and impact on the academic, financial; infrastructural and spiritual development of an institution of basic learning. From this definition, sponsorship is only limited to contribution. The impact of this limitation is that many sponsors have been sidelined by both TSC and the MoE in teacher management and governance of schools under the guise that they are not making significant contribution to the schools. This definition ignores the history of school sponsorship. Mission schools were started and developed by churches until after independence when the schools were handed over to government.

To maintain the religious tradition of the school, sponsoring churches maintained a close link and were regularly consulted on issues of teacher management and governance. Examples of such schools include St. Peters Mumias Boys' which was established by the Catholic Church in 1956. The school is built on a 65-acre piece of land that was purchased by the Catholic Church. 70% of infrastructure was put up by the church. It would therefore be unfair to require the Catholic Church to prove significant contribution within the meaning of the Basic Education Act, 2013 in order to qualify for consultation on teacher management and Governance of schools.

In conclusion, the law in books seem to differ significantly from what is going on in practice. Whereas the principals and head teachers of schools are supposed to facilitate the Boards of Management in the running of the schools, in practice, boards have been turned into rubber stamps, being technically driven by the agenda set by heads of institutions.

5.3 Recommendations

In view of tensions existing in teacher management and governance of public schools, the study suggests both legislative and policy review as discussed below.

5.3.1 Teachers Service Commission Act, 2012

There is need to review Teachers Service Commission Act, 2012 with regard to the provisions relating to deployment of head teachers and principals in public schools. The Act should be amended to provide for consultation and concurrence between Teachers Service Commission and relevant stakeholders in appointment of heads of institutions. Secondly, there is need for development of a policy framework establishing the nature and scope of engagement between TSC and MoE in teacher management and governance of schools. Such amendment and policy development would firm up the grip of the Ministry of Education in governance of public schools as heads would be partly answerable to the MoE.

This amendment will help to firm up the grip of the Ministry of Education in governance of schools as Boards of Management will have authority over principals and head teachers, as school managers, without encroaching on teacher management function of Teachers Service Commission.

5.3.2 Basic Education Act 2013

The Act should be amended to give clear definition and categories of sponsors. It should provide for founding sponsors, in relation to mission schools, and adopted sponsors in relation to churches

that have taken over existing schools. The sponsors are key players in teacher management because of the historical role they have played in Kenya's education sector.

5.3.3 Basic Education Regulations 2015

The Regulations should be amended in Section 5 to give the Cabinet Secretary exclusive powers to replace a principal or head teacher who abuses his or her agency, without necessarily making a request for replacement from the Teachers Service Commission. This is because governance of schools is a function of the Ministry of Education and the person exercising such delegated authority must be answerable to Cabinet Secretary of Education.

5.3.4 Composition of Teachers Service Commission

This study suggests a Teachers Service Commission structure similar to that of the United Republic of Tanzania. Under this model, even though the Teachers Service Commission exists as semi-autonomous entity under the Ministry of Education, the diversity of the membership of the commission enhances harmony among players in the education sector. The adoption of the model should be done with modifications so as not to interfere with the Constitutional status of the Commission as provided under Article 237 of the Constitution of Kenya. Section six of the Teachers Service Commission Act¹⁸⁸ of the United Republic of Tanzania provides that the Commission shall be composed of the Chairperson appointed by the President, a representative from the Ministry responsible for Education, a Representative from the Ministry responsible for local government, Representative from the Attorney General, representative from National Council for technical education, two representatives from the Teachers Unions and Commissioner for Budget or his representative. In Kenya, Teachers Service Commission Act, 2012 provide that the Commission shall be consist of a Chairperson and eight other members to be appointed in

¹⁸⁸ Act No. 25 of 2015

accordance with the Constitution. This composition ought to have brought on board representatives of major stakeholders in Education Sector. When the composition of the commission reflects a diversity of interest groups, tension is reduced.

BIBLIOGRAPHY

Books

- A.D. Woozley, *Law and Obedience, The Argument of Plato's Crito* (Chapel Hill, NC: University of North Carolina Press 1979);
- Chesoni, A. "The Evolution of Peace-net Kenya" in *Wajibu*, Vol. 10, No. 4. (1995) 2-3;
- Commission of Inquiry into the Education System of Kenya, Totally Integrated Quality Education and Training TIQET for Unity, Equity and Development. (Koech Report)*, (Nairobi: Government Printer 1999);
- Eshiwani, G. S., *Education in Kenya since Independence* (Nairobi: EAEP, 1993);
- Groome, T. H. *Education for Life. A Spiritual Vision for Every Teacher and Parent*, (New York: The Crossroad Publishing Company 1998);
- Indire, F.F. and Sifuna, D. N. *A History of the Development of Teacher Education in Kenya*, (University of Nairobi Press 1974);
- Kerlinger, F N, *Foundation of Behavioural Research, Administration Today*, (Charles Merrill Co. 2nd edn, New York 1973);
- Legum, C., *Africa since Independence* (Bloomington: Indiana University Press 1999);
- M.D.A Freeman, *Introduction to Jurisprudence*, (8th edn Sweet & Maxwell 2001);
- Maathai, W., *Unbowed: One Woman's Story* (London:William Heinemann 2006);
- Magesa L., *African Religion. The Moral Traditions of Abundant Life* (New York: Orbis 1997);
- Magesa L., *Christian Ethics in Africa* (Nairobi: Acton Publishers 2002)
- Magesa L., *Anatomy of Enculturationo. Transforming the Church in Africa* (Nairobi: Pauline Publications 2004)
- Mbiti, J., *African Religions and Philosophy* (Nairobi: EAEP 1969);

McLaren, P., *Life in Schools. An Introduction to Critical Pedagogy in the Foundations of Education* (New York: Longman 1989);

McMillan, J. H. & Schumacher, S., *Research in Education. A Conceptual Introduction* (New York: Longman 2001);

Ministry of Education Science and Technology, *Report of the Task Force on Student Discipline and Unrest in Secondary Schools* (Nairobi: Jomo Kenyatta Foundation 2001);

Mugambi J. N. K., *Christianity and African Culture* (Nairobi: Acton Publishers 2002);

Mugambi, J. N. K., *From Liberation to Reconstruction. African Christian Theology after the Cold War* (Nairobi: EAEP 1995);

Mugenda O. M, Mugenda A G, *Research Methods: Quantitative and Qualitative Approaches* (Nairobi: Acts Press 1999);

Mutua , M, *Development of Education in Kenya*, (Nairobi, African Literature Bureau 1975);

Mutua, R.W., *Development of Education in Kenya: Some Administrative Aspects* (Kampala: EALB 1975)

Otiende, J.E., Wamahiu, S.P. & Karungu, A.M. , *Education and Development in Kenya. A Historical Perspective* (Nairobi: Oxford, University Press 1992);

PLO Lumumba & Luis Franceschi, *The Constitution of Kenya, 2010; An Introductory Commentary* (Strathmore University Press 2014);

Sifuna, D.N.& Otiende, J.E. *An Introductory History of Education* (Revised Edition Nairobi: Nairobi University Press 1992);

Sushila B, *Management and Evaluation of Schools* (Oxford University Press 2004);

Waruta, D., *The Education Mission of the Church: An African Perspective. In Nasimiyu–Wasike, A. & Waruta, D., eds. Mission in African Christianity* (Critical Essays in Missiology Nairobi: Acton 2000, 123 – 149);

Wright T, *Roles of Teachers and Learners* (Oxford University Press).

Zajda J, *Decentralisation and Privatisation in Education; The Role of the State* (Ed) (2006).

Articles

Dorothy Owuor and Bonn Odera, “Teacher Management; Emerging Issues in Kenya” (2017) Vol.4, *European Journal of Educational Sciences*.

Hanson M, ‘Education Reform and Administrative Development: The Case of Colombia and Venezuela’ (1986) *Journal of Education Administration* 36, 2.

Hanson M, Democratisation and Decentralisation in Colombian Education (1995) *Comparative Education Review*, Vol. 39 No. 1

Loverde, P., 2006. Catholic Schools: Their Roles and challenges. In *Origins* Vol.35, No. 35, p. 587-590.

Mbae, J., 1995. Conflict Management and Resolution in our Schools. In *Wajibu*, Vol. 10, No. 4 p. 4 – 6.

Mugambi M, &Ochieng R, “Repositioning School Based Teacher Management in Kenya, Global Practices and Approaches” (2016), *International Journal of Education*

Ojwang’ M. A, “Effects of the Restructuring of Teacher Placement and On Teacher and Gender Distribution in Public Secondary Schools in Nakuru County, Kenya.” *Baraton Inter Disciplinary Research Journal*.

Oplakta I, Sheva B, The Context and Profile of Teachers in developing Countries in the Last Decade, *International Journal of Education Management*. Vol 21.

Robinson, D.W., 1965. “The Church, Schools and Religious Liberty” in *AFER* Vol. VII No. 1. pp. 9-22.

Conference Papers and Reports.

Ominde S H, (1964) *Kenya Education Commission Report, Republic of Kenya*, Nairobi. Government Printer.

Piotr&Jacek “New Public Management and Processes of Education”, (Management, Knowledge and Learning International Conference, Potorz, Slovenia. 25- 27 June 2014),

Sihanya B, “Constitutional Commissions in Kenya: Experiences, Challenges and Lessons.” (Conference on State Implementation of the Constitution since 2010. Laico Regency, November 20, 2013).

APPENDIX 1

INTERVIEW SCHEDULE

STUDY TITLE: *THE ROLE OF THE TEACHERS SERVICE COMMISSION AND THE MINISTRY OF EDUCATION IN TEACHER MANAGEMENT AND GOVERNANCE OF PUBLIC SCHOOLS UNDER THE KENYAN LEGAL SYSTEM.*

RESEARCHER: LUBENGU KENNEDY ECHESA

SUPERVISOR: DR. NKATHA KABIRA

INTRODUCTION

Thank you for giving me an opportunity to conduct this interview with you. I am pursuing a Masters in Law (LLM) at the School of Law, University of Nairobi. As part of the requirement for an award of the LLM Degree, I am expected to write a research paper in my area of choice in the legal realm. I have chosen to write a project paper on **The Role of the Teachers Service Commission and the Ministry of Education in Teacher Management and Governance of Public Schools under the Kenyan Legal System.**

This questionnaire is administered as part of my research on the topic aforementioned. The study aims at examining the concept of Access to Justice under Kenyan Legal System, with focus on timely resolution of matters before courts and other Tribunals.

The interview will take approximately 30 minutes.

As a participant in this interview, please note the following

- a) Your participation in this interview is purely voluntary and you can withdraw from the process at any time during the interview.
- b) The information you give will be treated with strict confidentiality.
- c) You are free to ask for clarifications at any point in the course of the interview
- d) Your responses will be recorded in the questionnaire only.

Do you agree to participate in the interview?

YES _____

NO _____

Please sign below to signify your consent

BACKGROUND INFORMATION

NAME (optional) _____

(To be treated with strict confidentiality if provided)

AGE _____

OCCUPATION _____

DATE OF INTERVIEW _____

TIME OF INTERVIEW

START _____ **END** _____

Gender:

Age bracket i.e. (30-40) :.....

Designation:

Years of service in the current designation:

Do you agree to take part in this interview?

If yes, please sign:

General Questions to all interviewees

1. For how long have you served as in your current position?

.....
.....
.....

2. What in your view is the difference between the period before 2010 and after 2010 with respect to discharge of your duties?

.....
.....
.....

3. What were your key roles before 2010?

.....
.....
.....
.....

4. What are your current roles?

.....
.....
.....

5. In your view, is there any tension in the discharge of your duties to your superior?

.....
.....
.....

6. What are the key administrative problems you are facing in discharge of your duties?

.....
.....
.....

7. What would be your proposals to help reduce the existing tension (if any) between TSC and the Ministry of Education in teacher management and governance of schools?

.....

.....

.....

Specific questions to County Directors and sub-county Directors of Education (both TSC & Ministry)

1. What are your roles (roles of your respective institutions) in assuring standards and quality in public schools?

.....

.....

.....

2. Who in your view should be responsible for quality assurance and maintenance of standards in public schools and why?

.....

.....

.....

3. Is there any role being performed by Ministry/TSC that you think should be performed by the Ministry/TSC with respect to teacher management and governance of public schools?

.....

.....

.....

4. What would you recommend for effective teacher management and governance of public schools?

.....

.....

.....

.....

My Observations:

.....

.....

.....

.....

.....

.....

.....

.....

.....

.....

.....

.....

.....

.....

.....

.....
.....