



# **UNIVERSITY OF NAIROBI**

## **SCHOOL OF ENGINEERING**

### **DEPARTMENT OF MECHANICAL & MANUFACTURING ENGINEERING**

#### **Research Project Report**

The Role of High Voltage Direct Current Technology in Transmission  
Planning for Renewable Energy Integration: A Case of Wind Energy

**RAKWACH KENNETH OUMA**

**Registration No: F56/8075/2017**

This project is submitted for the partial fulfillment of the requirement for the award of the  
Degree of Masters of Science in Energy Management of the University of Nairobi

#### **Supervisors**

Supervisor: Dr. Peter Moses M. Musau

2<sup>nd</sup> Supervisor: Dr. Abraham Mutunga Nyete

**Declaration**

**I. Student's Declaration**

This Master of Science project report is my original work and has not been presented for any degree award of the University of Nairobi or any other university for that matter.

**RAKWACH, Kenneth Ouma**

**Registration Number: F56/8075/2017**

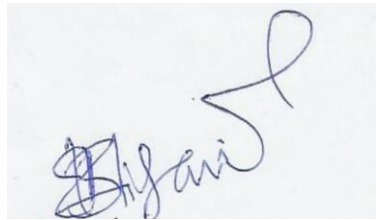

Signature .....

Date 8<sup>th</sup> February 2022

**II. Supervisor's Declaration**

This Master of Science project report has been submitted to the Faculty of Engineering, University of Nairobi with our approval as Supervisors:

**Dr. Peter Moses M. Musau**

Signature ..... 

Date ..... 21/02/22

**Dr. Abraham M. Nyete**

Signature ..... 

Date ..... 21/2/2022

## **Dedication**

To my family, both immediate and extended, to whom over the many months of my academic journey willingly taught me the values and virtues that matter – Diligence, Patience and Hard work

## **Acknowledgement**

This project would have not been possible without the unwavering and extraordinary support of a number of people.

I begin with my supervisors, Dr. Peter M .M. Musau and Dr. A. M. Nyete. Firstly, formulating a project title and seeing it through the writing process requires a lot of patience. Through the setbacks, false starts, editing, reviewing up to project submission my supervisors stood with me all through, providing the much needed and unquestionable professional guidance. I have been lucky to have you, and my gratitude to you is beyond measure.

Secondly, I would have never attained this level of academic excellence without the support of some of my classmates and technical assistance of a few. To this end, special mention goes to Ms. Herine O. Atieno, Mrs. Celestine K. Philip and Mr. Rotich who made the high level of excellence required seem attainable. They were consistently insightful, meticulous and full of enthusiasm on which approach to give the research and whenever I encountered setbacks. The Lord abundantly bless you and keep you always for your incredible friendship, skill and support.

Finally, my profound gratitude isto my immediate family. You have all in numerous ways been my ultimate source of inspiration and support.My deepest appreciation for all that you had sacrificed and given freely for it has tremendously made a world of difference.

# Table of Contents

<b>Declaration .....</b>	<b>i</b>
<b>Dedication.....</b>	<b>ii</b>
<b>Acknowledgement.....</b>	<b>iii</b>
<b>Table of Contents.....</b>	<b>iv</b>
<b>List of Tables.....</b>	<b>vii</b>
<b>List of Figures .....</b>	<b>viii</b>
<b>Some Useful Abbreviations.....</b>	<b>ix</b>
<b>Abstract .....</b>	<b>x</b>
<b>Chapter One: Introduction.....</b>	<b>1</b>
1.1 Renewable Energy Integration.....	1
1.2 Problem Statement .....	4
1.3 Research Objectives.....	4
1.3.1 Main Objective.....	4
1.3.2 Specific Objectives.....	5
1.4 Research Questions.....	5
1.5 Scope of Work .....	5
1.6 Relevance and Justification of Study.....	6
1.7 Contribution .....	6
1.8 Report Organization.....	6
<b>Chapter Two: Literature Review .....</b>	<b>8</b>
2.0 Introduction.....	8
2.1 Electrical Power System .....	8
2.2 Power from the Wind.....	9
2.3 The Basics of HVDC .....	11

2.4 HVDC in Renewable Energy Integration .....	12
2.5 Research Gap .....	13
2.6 Problem Formulation .....	13
2.6.1 VSC HVDC Transmission Link.....	14
2.6.2 Expanding Power Access with VSC HVDC Modulated Bipolar .....	16
2.7 Chapter Conclusion.....	18
<b>Chapter Three: Methodology .....</b>	<b>20</b>
3.0 Introduction.....	20
3.1 VSC HVDC Transmission Link .....	20
3.1.1 VSC HVDC System Configuration .....	21
3.2 Simulation Flow Chart.....	23
<b>Chapter Four: Results, Discussion and Analysis.....</b>	<b>26</b>
4.0 Introduction.....	26
4.1 VSC System Description .....	26
4.1.1 Rectifier Control Station .....	27
4.1.2 Base Parameters .....	29
4.1.3 Rectifier Arm Analysis .....	30
4.2 Inverter Analysis and Grid-side Synchronization.....	34
4.2.1 Error in Grid Pulse .....	36
4.3 Transmission Expansion Analysis .....	36
4.4 REI Economic Analysis.....	37
4.5 Validation.....	38
4.6 Chapter Conclusion.....	39
<b>Chapter Five: Conclusions and Recommendations.....</b>	<b>41</b>
5.1 Conclusions.....	41

5.2 Recommendations for Future Works .....	42
<b>References .....</b>	<b>43</b>
<b>Appendices .....</b>	<b>46</b>
Appendix I: Beaufort Scale.....	46
Appendix II: Inverter Side Signals and Graphs .....	47
Appendix III: Summary of VSC HVDC Projects (Worldwide).....	51
Appendix IV: Similarity Index Report .....	517

## **List of Tables**

Table 2.1: Major Components of a HVDC System.....	12
Table 2.2 Major VSC HVDC System and Control Components.....	13
Table 4.1: Base Parameter and Description .....	29



## List of Figures

Figure 1.1: Integrating Renewable Energy to the Electrical Grid [1] .....	2
Figure 1.2: Illustration of Wind Power Output Fluctuation [1].....	2
Figure 2.1: Integrating Wind Power to the Electrical Grid [1].....	9
Figure 2.2: Horizontal-axis wind-turbine .....	10
Figure 2.3: Major Components of a HVDC System [9].....	11
Figure 2.4: Dual Terminal VSC-HVDC Transmission Link.....	15
Figure 2.5: VSC HVDC Modulated Bipolar Configuration.....	17
Figure 3.1: Block Design of VSC HVDC Transmission Link .....	20
Figure 3.2: Rectifier Arm of the VSC HVDC .....	21
Figure 3.3: Inverter Arm of the VSC HVDC .....	22
Figure 3.4: Steps to the Simulation Process Flowchart.....	23
Figure 4.1: VSC HVDC Transmission Link .....	27
Figure 4.2: Schematic layout of Rectifier Control Station .....	28
Figure 4.3: Graphical Representation of Real and Reactive Power of VSC HVDC against time .....	31
Figure 4.4: Graphical Representation of RMS AC Voltage against time .....	31
Figure 4.5: Graphical Representation of Real Power against time .....	32
Figure 4.6: Graphical Representation of AC Voltage Power Flow against Time .....	32
Figure 4.7: Graphical Representation of Active Power Flow against Time.....	33
Figure 4.8: Graphical Representation of Reactive Power Flow against Time .....	33
Figure 4.9: Graphical Representation of Voltage Balance Control Waveform (Rectifier Side).....	34
Figure 4.10: Graphical Representation of Voltage Balance Control Waveform Inverter Side.....	35
Figure 4.11: Inverter Side Control System.....	36
Figure 4.12: The Wind Resource Map of Kenya [12].....	38

## Some Useful Abbreviations

AC	Alternating Current
CIGRE	Conseil International des Grands Réseaux Électriques
DC	Direct Current
ESS	Energy Storage System
FACTS	Flexible Alternating Current Transmission Systems
GHG	Green House Gases
GW	Giga Watts
HAWT	Horizontal Axis Wind Turbine
HVAC	High Voltage Alternating Current
HVDC	High Voltage Direct Current
IGBT	Insulated Gate Bipolar Transistor
LCC	Line Commutating Converter
PCC	Point of Common Coupling
REI	Renewable Energy Integration
RET	Renewable Energy Transmission
VSC	Voltage Source Converter
WECS	Wind Energy Conversion System

## Abstract

Renewable Energy Integration (REI) to the electrical grid comes with various technical challenges. One of these challenges is the need to upgrade the existing transmission infrastructure given the significant distance between the geographical locations of renewable energy power plants and the intended point of use (POU). VSC HVDC technology possesses a plethora of merits that make this system of transmission the choice alternative for Renewable Energy Transmission (RET) over long distances.

However, electricity generation from Renewable Energy Sources (RES) like Wind power, Solar power and Wave energy come along with certain distinct characteristics that makes the goal of grid integration and long distance RET daunting. Wind, for example is very unpredictable— the ripple effect of this unpredictability is that the availability of output of power at POU will also fluctuate, so much so that without auxiliary support secure, reliable and quality power cannot be dispatched. The complexity is augmented when even scheduling generation in advance cannot be planned for because of the uncertainty of the power output at POU.

One method of auxiliary support is VSC HVDC. VSC HVDC can independently create an AC voltage from DC voltage for the exchange of active and reactive power within the HVDC transmission link. This injection of active and reactive power is paramount when it becomes needful to stabilize the forecasted power so that the voltage and frequency of the electrical is maintained. Fluctuations of voltage and frequency are among the core precipitators hampering the viable health of the power system infrastructure. This project VSC HVDC that was simulated in a MATLAB environment for offshore wind power integration and the results obtained demonstrated the need to adopt HVDC for the evacuation of RE power and transmission over long distances.

*Keywords: Renewable Energy Integration (REI), Renewable Energy Transmission (RET), Voltage Source Converter (VSC), High Voltage Direct Current (HVDC), Location of RE, Cost of RE, Point of Use (POU), Wind Energy.*

# Chapter One: Introduction

This chapter introduces the necessity of Renewable Energy Integration to the grid and the attendant challenges where the goal of grid integration cannot be gainsaid to cut dependence on fossil-fuel based energy sources. These challenges have been discussed, as the report goes further to capture the problem statement and the project objectives. The scope and justification of this project has been anchored on the essence of HVDC for REI given the relative abundance and maturity of renewable energy, especially wind power, for large scale use and long distance transmission. Finally, the last part is the report organization outlining the structure of the rest of the report.

## 1.1 Renewable Energy Integration

Even though ubiquitous, integrating renewable energy to the electrical grid poses a number of challenges, owing to the fact power output from RES is largely uncertain. This uncertainty is compounded by unpredictability, locational specificity and a variability that cannot be easily controlled [1]. Several RE plants that share its energy with the grid are in large scale capacity, therefore the area of such one plant is often considerable. Location specificity, for instance, is determined by several factors such that each Renewable Energy technology (RET) has a set out criteria before such a plant is set up. Picking a place to operate a particular RET involves taking into consideration many elements to be able to reliably integrate RES with the grid. Distance is also another critical factor as the distance between the RE plant and the POU is significant, in some cases even traversing regions. This distance conundrum is a major aspect in terms of cost and efficiency. Locational specificity also does not necessarily make it easy for the transmission of RE power, thus they require transfer power, by extension transmission lines that depend on the voltage level. Therefore, designing of new or upgrading of the existing transmission and distribution network becomes a challenge with REI. [2]. Figure 1.1 shows a general layout of how renewable energy is integrated into the electrical grid.

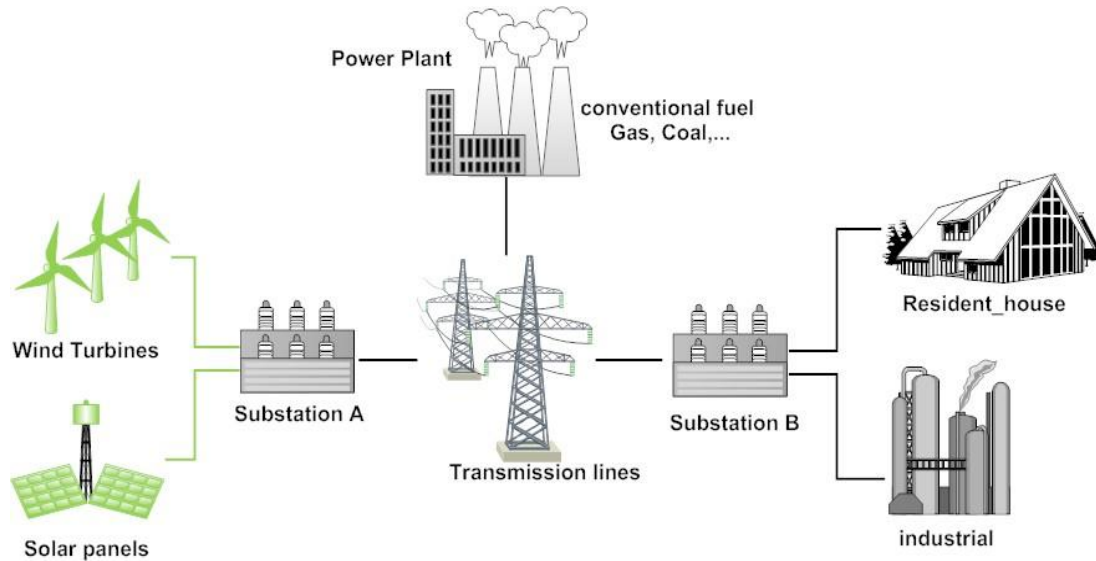

**Figure 1.1: Integrating Renewable Energy to the Electrical Grid [1]**

Power output from RES as shown in Figure 1.2 fluctuates in a way that is very difficult to control given that RES availability varies momentarily. This RES random behavior pose a unique challenge to the grid which obligates the provisional support for the instantaneous maintenance of power supply and demand. Fluctuations of voltage and frequency are a great threat to the technical and economical viable health span of the Power System Infrastructure (PSI).

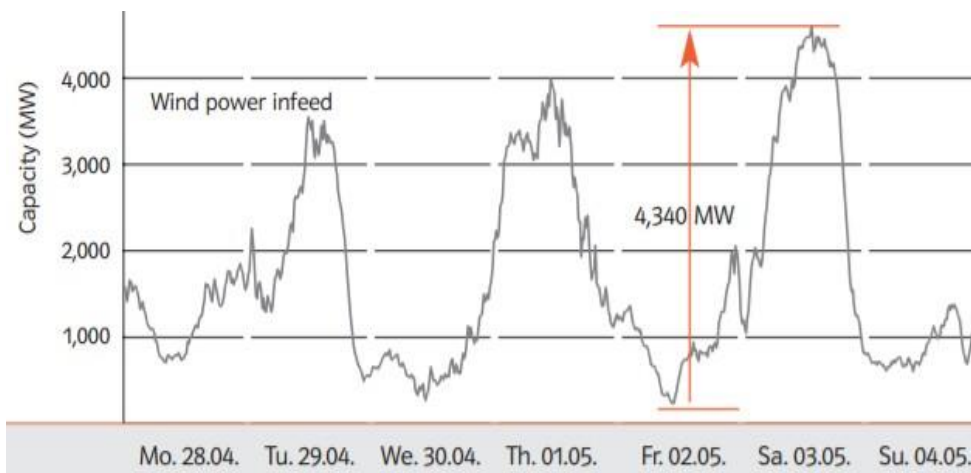

**Figure 1.2: Illustration of Wind Power Output Fluctuation [1]**

Therefore, to protect the PSI injection of active and reactive power into the electrical grid is paramount and becomes ever so needful to achieve stabilization of the forecasted power for the voltage

and frequency of the PSI to be also maintained as well. Besides, the injection of real and reactive power other critical auxiliary support strategies include:

- (i) Spinning and Non-spinning reserves: Typically these are generators that continue to inject power to the PSI in the event of a fault with any of the generators. The difference between the two is in the call-to-action response time where the response time of spinning reserves are much more prompt.
- (ii) Black Start Capability: Black start is how slow or fast a power system recovers from a shutdown condition to regain normal operation [5].

Unpredictable availability of RES is another REI challenge. Circumventing this challenge often and always requires sophisticated forecasting technologies that can be able to provide accurate and timely information whenever there is an under- or over-generation of RES supply. The challenge this poses to the PSI is that the management of bulk-power is operationally carried out through “unit commitment”. This is a technical practice of scheduling generation ahead of time and in the event of under- or over-generation the difference has to be balanced and compensated for. Now, the increase of the spread of forecasted generation and actual generation (energy supplied) is directly proportional to the cost of RE generation, and where this cost function increases it is the customers that bear the cost. Therefore, the composite technique of energy management through unit commitment a practice already seen as deterministic against stochastic generation as already seen with RE carries with it a fair share of uncertainty and to a considerable extent a great deal of complexity such as: sophisticated forecasting technologies; cost effective communication of these forecasts with grid operators; and, economical load dispatch resources; all for the PSI to be flexible and friendly to RES [5].

Achieving flexibility and friendliness of the electrical grid to RES, no matter how complex or uncertain, is critical to the integration of RE resources. For one, the PSI would be able to last longer and pave way for lifetime extension strategies that prevent the adverse exposure of the power system to reliability and operational risks. If left unattended or not looked into, this indifference may only serve to reverse the efforts, currently being made, towards cutting dependence on fossil-fuels – energy sources that emit toxic greenhouse gases to the environment.

## **1.2 Problem Statement**

The generation of renewable energy cannot yet be considered and treated as a “must-take” resource for the reasons discussed in the previous section. To accommodate bulk generation of RE generation requires a large scale transmission grid expansion and reinforcement for the following reasons [3]:

- (i) Grid expansion and inter-regional connection are needed to transmit the energy generated by large capacity RE sources, which are generally located far from the load centers and the existing grid;
- (ii) Through grid expansion, the geographic diversity of RE generation can be exploited to smooth their aggregated variability and uncertainty and to reduce the RE power forecast error;
- (iii) Grid expansion and reinforcement can support interconnection between balancing areas, hence facilitating their cooperation or consolidation to share flexibility resources.

Efficient and effective exploitation of RE cannot be contemplated in the absence of HVDC systems. However, a lot of effort is and has been concentrated on RE generation without a consideration of the same apportioned to RET. HVAC was conceived several years ago when energy demands and needs were not as complex as they are today. Even though, the transmission of renewable energy has been mentioned in literature, a conscious effort of renewable energy access in metropolitan areas is yet to be made. This project brings to the fore the role of HVDC Technology in Transmission Planning with REI for the conceptualization of how access to energy could be made by relying more on RES via a transmission network that is resilient; guarantees power quality; RE-friendly; flexible; and, forward-looking.

## **1.3 Research Objectives**

### **1.3.1 Main Objective**

To simulate a VSC-HVDC transmission link system that is based on RE. This link demonstrates how renewable energy can be transmitted, and subsequently distributed power for medium scale use.

### **1.3.2 Specific Objectives**

The specific objectives identified were as follows:

- (i) To develop and have a good background on the concept and behavior of VSC-HVDC transmission and practical application with RES.
- (ii) To address the importance of transmission planning with HVDC Technology for sustainable integration with REI through conversion of loaded AC lines to DC.
- (iii) To determine energy access expansion using HVDC through increase in transmission capacity for sustainable integration with REI.

### **1.4 Research Questions**

- (i) How does the conversion of existing AC line into DC present a better alternative to the power carrying capability and transmission capacity for expanded RE access?
- (ii) How can an existing transmission line be assessed for transmission expansion to be able to accommodate RE whether in medium or large capacity?
- (iii) Is it possible to exploit HVDC for shorter distances? If yes, in what will be the most practical application?
- (iv) What are the necessary challenges impeding the integration of renewable energy to the grid and subsequent dispatch?

### **1.5 Scope of Work**

The scope of this project was limited to a simulation in exploring the role of HVDC Technology in Transmission Planning with REI by focusing on wind power. It did not necessarily recommend overhauling the conventional electrical infrastructure to accommodate RES but rather conceptualize an approach that makes the most of what is in existence with the aim of modernizing its features to adapt to the electrical needs and trends of the future. The simulation entailed designing a VSC HVDC link that takes advantage of an existing AC corridor and transforming its attributes to DC. MATLAB/SIMULINK was used to simulate the HVDC link. RE sources are naturally DC in nature, thus the renewable source contemplated in this research was wind. A voltage source converter



can independently create an AC voltage from a DC voltage source for the exchange of active and reactive power an operational principle of that accommodates both the distinct attributes of AC and DC on one platform.

### **1.6 Relevance and Justification of Study**

The integration of RE with the electrical grid carries along with it a good share of non-controllable variability and uncertainty. For this integration to be worth its salt coupled with the need to break-free from generating electricity from sources that cause irreparable harm to the natural environment, forward-looking solutions and strategies ought to be put in place to address the concatenated difficulties and complexities already discussed. Solutions such as modernizing the transmission system and technology; advanced management of unit commitment; and, expanding energy access owed to RE injection among other solutions altogether to have in place a flexible and friendly PSI for an improved power system efficiency and real-time load and generation balancing can only be achieved with HVDC. Indeed, only HVDC can be able to harmonize the complex nature of RE with the grid where the quality of power can be guaranteed.

### **1.7 Contribution**

Little is still being done about RET. This project took advantage of the ongoing effort on RE generation and attempted to look into how key existing transmission networks could be modernized to adapt to the electrical energy trends of the future which is incorporating RE in the electrical grid. These new set of generation and transmission requirements can be only effectively and efficiently managed within the context of HVDC. HVAC corridors which are located near rich sites of RE can be converted to High Voltage Direct Current corridors. On this basis, this project sought to contribute to modern transmission technologies and their practical application to pave way for a more secure, reliable, resilient and cleaner electrical future.

### **1.8 Report Organization**

This report discusses the role of HVDC in transmission expansion with renewable energy integration. Chapter 1 as already reviewed presented the present scenario with the aim of defining steps to take towards a reliable and secure electrical future. Chapter 2 reviews the technology of electricity

transmission – conventional vis-à-vis modern modes. Configurations for converting AC corridors to DC were also discussed. Chapter 3 describes the research design and methodology the research adopted. The simulation of a VSC-based HVDC transmission link is explained as the design process adopted in the project. Chapter 4 discusses and analyzes the results and findings of the research. The project summary, conclusions and future recommendations are outlined in Chapter 5.

## Chapter Two: Literature Review

### 2.0 Introduction

This chapter reviews the basics of HVDC and the role of HVDC in REI especially windpower. It discusses the emerging trends that influence large-scale integration renewable energy into the power grid; explores the gap in research with respect to RET and on the basis of what is has been and currently is being undertaken both locally and globally.

### 2.1 Electrical Power System

A transmission network comprises of several transmission lines, these transmission lines can be of different voltage ratings: (1) Low Voltage; (2) Medium Voltage; and, (3) High Voltage. See Figure 1.1. The main role other than the transmission of electrical energy, they can also be utilized in interconnecting other power utilities besides transferring power from one region to another. The typical range of electrical power generation is between 11kV and 25kV through the existence of power plants. This harnessed power which is usually stepped-up for long distance transmission and the minimizing of power loss is transported via high voltage transmission lines. Once the electrical power reaches the substation it is stepped down using transformers to ranges between 66kV to 400kV for convenient distribution from the substation to load centers. At the substation the quality of electricity is regulated and the isolation of potential faults eliminated with the aid of circuit breakers. On exiting the substation, the electrical power is further stepped down and then transported through feeder lines for domestic, commercial and industrial use. Figure 2.1 is an illustration of how wind power is injected to the electrical grid. Transmission lines have four basic components – inductance, capacitance, resistance and shunt conductance. The inductance connected in series regulates the transmission power capacity of the transmission line. The capacitance (shunt capacitance) enables the charging current to flow in the line. Resistance (series resistance) in the transmission line is the real power in the transmission line and usually informs the basis of evaluating the efficiency of transmission. Lastly, shunt conductance is what explains the leakages of current as electrical current flows through the insulators and pathways that are ionized in the air [6].

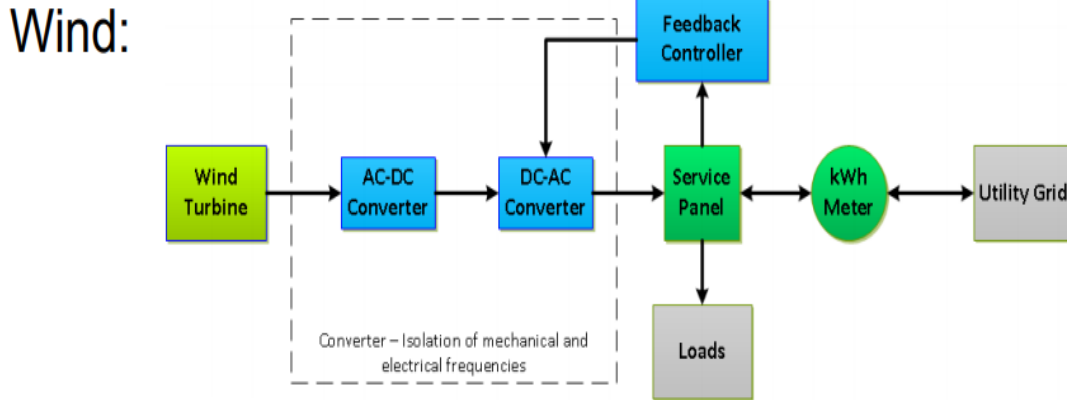

**Figure 2.1: Integrating Wind Power to the Electrical Grid [1]**

## 2.2 Power from the Wind

All turbines possess a limit by for extracting electrical power with the maximum as provided for by the Betz Criterion as  $C_{p(\max)}$  59.3%. Wind, by virtue of its motion, contains energy. Thus, any device capable of slowing down the mass of air in motion such a device is capable of extracting energy from the wind.

The kinetic energy of an object is the product of that object's mass and its velocity squared. Expressed as follows

$$\text{Kinetic Energy} = \frac{1}{2} mv^2 \quad (2.1)$$

From equation 2.1, we let  $m$  represent the mass of air particles, whereas  $v$  denotes the wind speed in m/s before interacting with the turbine.

But, mass of an object can be represented as the product of its density and volume, and further substituting this in equation 2.1 we obtain the equivalent of kinetic energy expressed per unit time as:

$$\text{Kinetic Energy per unit time} = \frac{1}{2} \rho Av \cdot v^2 = \frac{1}{2} \rho Av^3 \quad (2.2)$$

Where  $\rho$  denotes air density. The non-steady instantaneous power extracted by the turbine is obtained by multiplying equation 2.2 by  $C_p$ . Thus, the expression of non-steady instantaneous power becomes:

$$P_{(t)} = \frac{1}{2} C_p \rho Av^3 \quad (2.3)$$

$C_p$  is the power coefficient or aerodynamic efficiency and it is a non-linear function of the tip-speed-ratio and blade pitch angle. Therefore for any wind speed there is a corresponding rotor speed for which the value of  $C_p$  is maximum. The Beaufort scale (Appendix I) classifies wind speeds from visual observations. It gives details together with the relationship of various clusters of wind speed [8].

In John et al [8], the extraction of electrical power from the wind is made possible through wind turbines. Wind turbines extract energy from the wind by converting the kinetic energy of the wind into mechanical energy and then into electrical energy. The conversion of electrical power is made possible through the aerodynamic rotor which comprises of blades and hub that are linked to a transmission system and further linked to an electric generator. Figure 2.2 depicts a pictorial block diagram of a horizontal-axis wind turbine. The entire assembly which comprises of the aerodynamic rotor, nacelle, including other actuating and control systems matched to an electric generator is what comprises of a wind energy conversion system (WECS). The tower supporting the WECS control unit varies from a height of 45 m to 105 m. However, for industrial applications most towers average at a height of 80 m.

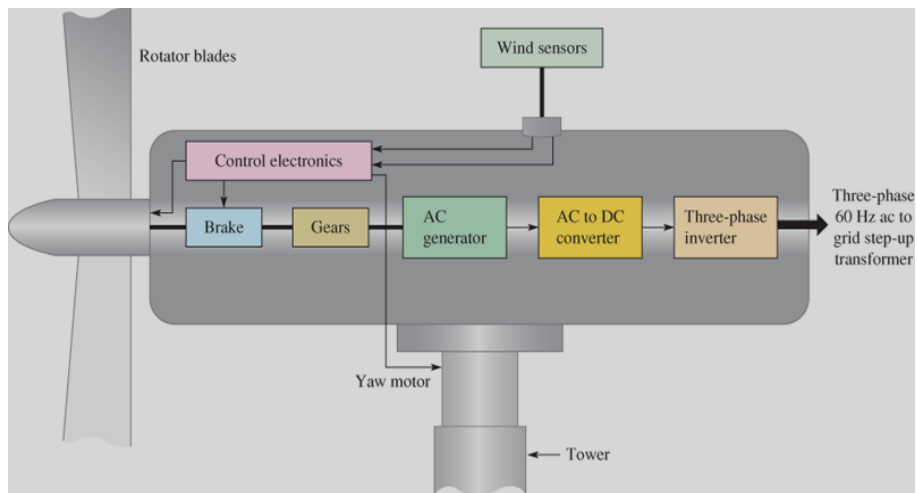
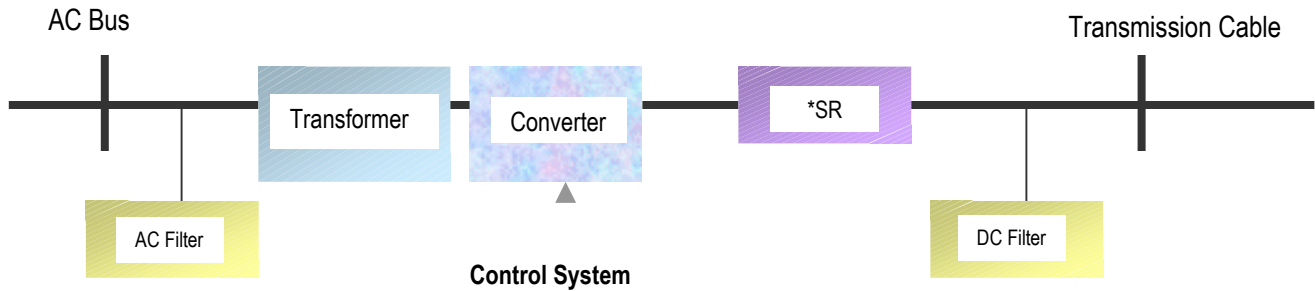

**Figure 2.2: Horizontal-axis wind-turbine**

Given the fluctuation of wind speeds, a wind turbine can produce power from wind speeds of about 3m/s to a maximum output of approximately 12m/s and the power output of a wind turbine increases by one third increase of wind speed. The average lifespan of a typical modern wind turbine is between 20 to 25 years.

### 2.3 The Basics of HVDC

The operation principle of HVDC is made possible by the aid of converters. These converters are of two types: (1) inverters; and (2) rectifiers. Rectifiers perform the function of changing the current carried in the conductors from AC to DC whereas inverters will do the opposite which is to change the current from DC to AC. Figure 2.2 is an illustration of the major components of a typical HVDC system. Any typical HVDC system will either be *monopolar* or *bipolar*. In monopolar configuration the HVDC system has a single high voltage conductor plus ground return whereas in the bipolar the HVDC system has double high voltage conductors with another conductor having a dual polarity of either positive or negative.



\*SR Smoothing Reactor

**Figure 2.3: Major Components of a HVDC System [9]**

The role of each component are as briefly described in Table 1. There are two main HVDC transmission technologies namely the line commutated converter (LCC) and voltage source converter (VSC) with the factor of differentiation being in their modes of commutation. In the case of LCC the conversion operation principle relies on an AC voltage where the switching action, whether controlled or not, is by thyristors. VSC on the other hand uses the concept of forced switching that is based on insulated gate bipolar transistors and does not require an AC line voltage for its operation.

**Table 2.1: Major Components of a HVDC System**

<b>Core Component</b>	<b>Function</b>
Thyristor or IGBT valves	Connected in series main role is the conversion of AC to DC.
Converter Transformers	Changes the voltage level of the AC busbar to the required voltage.
Harmonic Reactors	Supply of active power & Absorption of harmonic currents generated by HVDC converter
Surge Arresters	Over-voltage protection

According to Li et al. [7], HVDC is increasingly becoming popular given its grid-friendly compatibility and providing favorable access to distributed renewable energy. Some of the desirable merits are:

- (i) HVDC overhead lines have a low carbon footprint on the environment as opposed to HVAC overhead lines;
- (ii) It is easier to contemplate off-shore grid connection through underwater cabling with HVDC;
- (iii) HVDC over long distances have low transmission losses;
- (iv) HVDC have no reactive power thus no reactive power compensation is required;
- (v) Black start is how slow or fast a power system recovers from shutdown condition to attain and regain normal operation. Re-energizing a HVDC line from shutdown can be achieved without other devices such as generators.

#### **2.4 HVDC in Renewable Energy Integration**

Generation of electricity from RE is on the increase owing to the fact typically no cost is incurred with respect to electricity generation, and only when this is contrasted with generating electricity from fossil-fuels. This generation capacity as it grows; and, RE power plants intensify their capacities; transmission of this bulk power will become essential, and more so in a way that is cost-effective, secure, efficient and reliable. According to Li et al [10], a transmission technology that addresses the complexities and challenges encumbered by REI and RET, taking into consideration the distance between the RE power plants and intended POU; whilst factoring in the dissimilarity between RE and conventional power systems of generation in large-scale ought to be the integration and transmission solution of choice for RE. Solutions such as modernizing the transmission system and technology; advanced management of unit commitment; and, expanding energy access to allow for increasing RE generation cannot be accomplished with HVAC. Indeed, only HVDC can be able to

harmonize the complex nature of RE with the grid. The ability to solve REI challenges, for which we have seen inclines most with HVDC transmission technology, will safeguard the achievement of RE goals, and drive up the cost to reliably integrate these new resources into power systems.

## **2.5 Research Gap**

Integration of renewable energy to the utility power system is still at its infancy and only a handful of consumers have access to this dual energy supply, which implies that this dual connectivity is still not easily accessible and likely attributable to a lack of forward-looking solutions and strategies. Reviewing the integration process, thus far, reveals an inconsistency and incompatibility with the challenges that REI comes with; contrastingly focus is still on electricity generation from RES. Key indicators why HVAC corridor conversion to DC is an overlooked alternative:

- (i) Stability from the impact of using non-renewable sources cannot be solved by harnessing RE generation alone;
- (ii) Quite a number of people are still without access to reliable electricity despite the abundance of RES. A transmission bottleneck not a generation one;
- (iii) Most viable RE rich sites are miles away from metropolitan and urban centers which poses a threat on how demand for energy will be met against a population that is constantly growing;

This project addresses REI and RET, two additional crucial elements that complete the whole for the goal of RE to be attained. The simulated VSC HVDC transmission link demonstrates, though in part, how the RET and REI nexus can be merged to solve for the transmission gridlock of RE and make most of the RE generated to meet energy demand. Each pie of the whole: RE generation; RET; and, REI represents a unique attribute towards prudent energy investment and electrical system decarbonization. It is only when the three are interlinked that the glaring gaps and complexities of energy demand can be addressed.

## **2.6 Problem Formulation**

Reducing the cost of energy through cutting dependence on non-renewable sources of energy on one hand; whilst, integrating renewable energy to the electrical grid on the other hand; are multi-nodal



challenges requiring complex multi-nodal energy management strategies. The growth of RE on the electric grid is increasing so as to contribute towards de-carbonization of the energy system and also expand the access to energy. This shift in generation requires a shift in how electrical energy is also transmitted as well. HVDC addresses the issue of transmission capacity expansion rather than the construction of new lines, by transforming the critically loaded AC lines operating above their rated transmission capacities to meet DC requirements. By this approach these lines will be able to take in and transmit more power. VSC HVDC on the same vein addresses the issue of integrating RE into the grid for effective and efficient transmission of wind power. IGBT-based VSC HVDC is capable of transmitting low even up to zero active power which is compatible with the intermittent and broad-ranged fluctuation of wind power – a unique feature that lacks with HVAC or LCCs.

### 2.6.1 VSC HVDC Transmission Link

The control circuits of the VSC HVDC are driven by pulse-width modulation which in principle self-commutates. VSC can independently create its own AC voltage from a DC voltage source for the purpose of exchanging active and reactive power within the transmission link. At the point of common coupling – the point that connects the VSC to the converter transformer – is where the exchange of power is initiated. The output voltage content of the VSC and the phasor reactor harmonics is minimized by the AC filters during the switching process. The major systems and control components have been summarized in Table 2.2.

**Table 2.2: Major VSC HVDC System and Control Components**

<b>System/Control Component</b>	<b>Main Function</b>
AC-Side Transformer	Paris converter station connection to the AC system
Phase Reactor	Enabling active/reactive power transfer between VSC & AC
AC-Side Filters	Sinusoidal smoothening attributed to switching harmonics
DC-Side Capacitor	Voltage stabilization & DC side voltage ripple reduction
DC Lines	Power transmission between the two VSC stations.

Therefore, in order to obtain a steady direct voltage from the AC voltage generated from the converter on the AC side, the DC side capacitors smoothen the voltage ripples/spikes. These

capacitors play a vital role as the converter's provisional energy storage device so as to absorb and maintain power balance during the transient moments. Figure 2.3 is a schematic representation of the fundamental concept of a dual terminal VSC-HVDC transmission link.

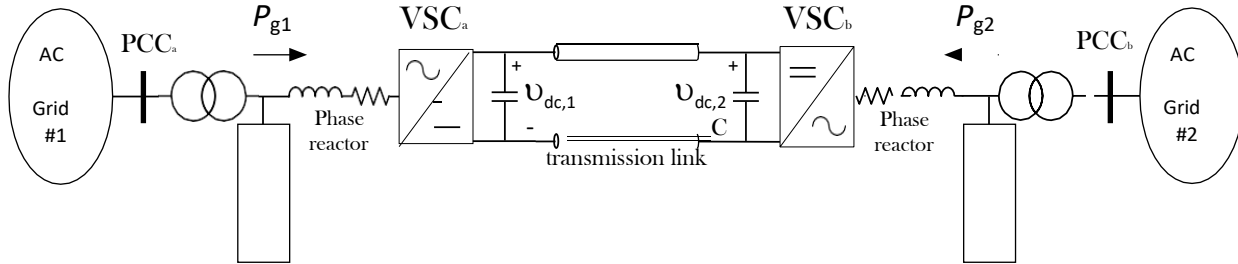

**Figure 2.4: Dual Terminal VSC-HVDC Transmission Link**

The maximum power that can be transmitted from the sending end to the receiving without loss of synchronism is what determines the limit of the steady state. Analyzing the AC voltage control can be described mathematically as:

$$P_{VSC} = [(U_{cabc}U_{abc}) / X] \sin \delta \quad (2.1)$$

$$Q_{VSC} = [(U_{cabc}U_{abc}) \cos \delta - U_{abc}^2] / X \quad (2.2)$$

Where

$P_{VSC}$  = Active power transmitted by the VSC-HVDC link

$Q_{VSC}$  = Reactive power transmitted by the VSC-HVDC link

$X$  = the reactance given by  $\omega L$

$U_{cabc}$  = this is the RMS value of line to line voltage at the converter output

$U_{abc}$  = RMS value of line to line voltage at the AC bus

$\delta$  = Phase angle difference between  $U_{cabc}$  and  $U_{abc}$  which are negligible such that  $\sin \delta = \delta$  and  $\cos \delta = 1$

Equations 2.1 and 2.2 thus yield

$$P_{VSC} = [(U_{cabc}U_{abc}) / X] \delta \quad (2.3)$$

$$Q_{VSC} = [U_{abc}(U_{cabc} - U_{abc})] / X \quad (2.4)$$

Equation 2.3 regulates the active power for it to be proportional to the phase angle difference whereas equation 2.4 regulates the voltage. Larruskain et al. [4], point out that voltage instability is usually as result of progressive uncontrollable voltage due to change in the condition of the system, load increase or disturbance. On account of VSC technology to be able to control active and reactive power guarantees to a considerable extent an improvement of power quality and voltage stabilization at the point of common coupling in the AC line. For example, it is feasible with VSC to evacuate energy from wind power plants without additional compensation and even though at the AC side (at PCC) the grid is notably weak improving the short-circuit power is not necessary. Some of the VSC-HVDC merits include:

- (i) Within its rated MVA, VSC-HVDC can swiftly control real and reactive power which implies transmission of very low of up to zero active power is possible and thus well adapted to the rapid and frequent fluctuation of RE power;
- (ii) The terminals of VSC-HVDC can generate reactive power to the level of the connected AC grid whereas CSC-HVDC terminals absorb reactive power during operation thus requiring a huge amount of reactive power compensation. This attribute makes VSC-HVDC an excellent provider of voltage support to the AC grid;
- (iii) VSC-HVDC requires no strategy or topological changes of the converter station control system in order to achieve reversal of the reactive power direction as CSC-HVDC requires. Reversing the direction of reactive power can be achieved by reversing current with the voltage polarity left as-is;
- (iv) To be sufficiently strong VSC-HVDC does not require AC grid support for commutation thus can be connected to passive or weak AC grids whereas to be sufficiently strong CSC-HVDC requires an AC grid connection [5].

### **2.6.2 Expanding Power Access with VSC HVDC Modulated Bipolar**

There are two types of AC lines namely Single Circuit AC Lines; and, Double Circuit AC Lines. Modifying these lines to meet DC requirements without altering the tower structure and tower design

can be achieved either through replacing the insulators to match the required DC voltage or changing the conductors. The latter yields a higher increase in power of which is considered in this research. It only considered single AC circuit as well even though double AC circuit can also be converted as well.

In Xydis [11], Redundancy is the addition or inclusion of single or multiple components of a system unnecessary to system functionality in the event of either a fault or failure (total or partial) in other components. Expressed mathematically as:

$$R_{C-L} = P_{C.out} / P \quad (2.5)$$

Where  $R_{C-L}$  is the conductor loss redundancy,  $P_{C.out}$  is the maximum power carried by a single conductor and  $P$  is the total power. AC line conversion into bipolar DC line or into tripolar DC yields a redundancy of approximately 57% and 84% respectively. But, in the event of conductor fault or failure in the case of conversion into bipolar DC yields a 100% redundancy. On grounds of redundancy prudence, conversion to modulated bipolar yields zero redundancy, and even in the event of conductor fault close to 90% of the power can be recovered. Figure 2.4 illustrates a VSC HVDC modulated bipolar configuration.

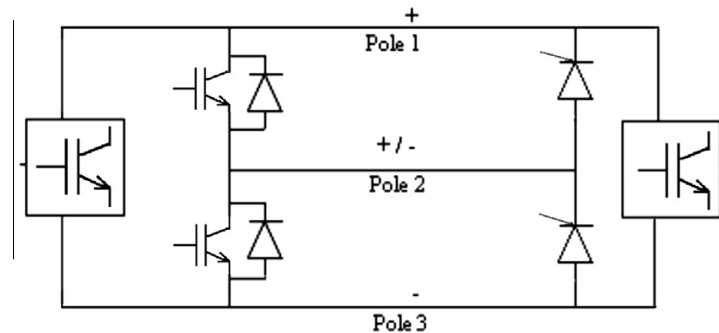

**Figure 2.5: VSC HVDC Modulated Bipolar Configuration**

The limit of currents represented as  $I_{max}$  and  $I_{min}$  of the first and third poles is as follows:

$$\frac{1}{2} (I_{max} + I_{min}) = 1 \quad (2.6)$$

$$\text{And, } I_{min} = \frac{1}{2} (I_{max}) \quad (2.7)$$

The modulated power from the bipole is represented as

$$P_{DC} = 1.26 I \times U_{PG} + 2(0.63 I \times U_{PG}) = 2.53 I \times U_{PG} = 1.26 P_b \quad (2.8)$$

Where  $1.26I$  is instantaneous current for pole 1 and  $0.63I$  is the instantaneous current for poles 2 and 3. From this we observe the amount of increased transmissible power is 1.26 times above bipolar. Moreover, when a conductor fails almost 91% of the power can be recovered.

$$R_{C-L} = [(I \times U_{PG}) \times (1.15+1.15)] / (2.53 \times I \times U_{PG}) \times 100 = 91\% \quad (2.9)$$

The power transmitted through an AC line where conversion to DC is envisaged is represented as:

$$P_{AC} = 6E_p \times I_L \quad (2.10)$$

Subsequently, power in DC transmission as follows:

$$P_{DC} = 6V_d \times I_d \quad (2.11)$$

Considering similar situations of cable insulation and current the DC and AC power ratio takes the following relationship:

$$(P_{DC}/P_{AC}) = (V_d/E_p) * (k * (k_1/k_2)) \quad (2.12)$$

For similar values of  $k$ ,  $k_1$  and  $k_2$  the transmitted power by overhead lines can be raised by a percentage margin of 147% and the line losses brought down by 68%.

## 2.7 Chapter Conclusion

Several projects worldwide have been undertaken using VSC HVDC technology. Appendix II gives a detailed summary of these projects. The selected projects highlighted below have a bias with renewable energy integration:

- i) Gotland, Sweden for onshore wind power integration. Year of commissioning 1999
- ii) Tjæreborg, Denmark for testing offshore wind power integration. Year of commissioning 2000
- iii) Nord E.ON 1, Germany for offshore wind power integration. Year of commissioning 2009
- iv) Shanghai Nanhui, China for offshore wind power integration. Year of commissioning 2011.
- v) Barsoor and Lower Sileru, India Double Circuit AC conversion into a bipolar DC configuration. Ongoing.

This reveals a gradual maturity and acceptance of VSC technology, which is also available for medium scale power transmission useful for towns and urban centers that in the long-run supports RE penetration. Its application is already seen in supplying power to islands; power infeed into metropolitan areas; remote small scale and offshore generation; multi-terminal systems just to mention.

# Chapter Three: Methodology

## 3.0 Introduction

The objective of this chapter is to provide an overview of the technique the research adopted in formulating an appropriate solution for renewable energy transmission. A description of the simulation process has been explained, with the same ratified in a series of steps.

## 3.1 VSC HVDC Transmission Link

The block design of VSC HVDC transmission link in Figure 3.1 was simulated using MATLAB/SIMULINK R2019b at the Department of Electrical and Information Engineering, Telecommunications Laboratory – American Wing Room 309. MATLAB is a programming language for numerical computing, programming and visualization that allows for matrix manipulations, plotting of data and functions, creation of models and applications, data analysis, developing and implementing algorithms and interfacing with programs written in other languages e.g. python.

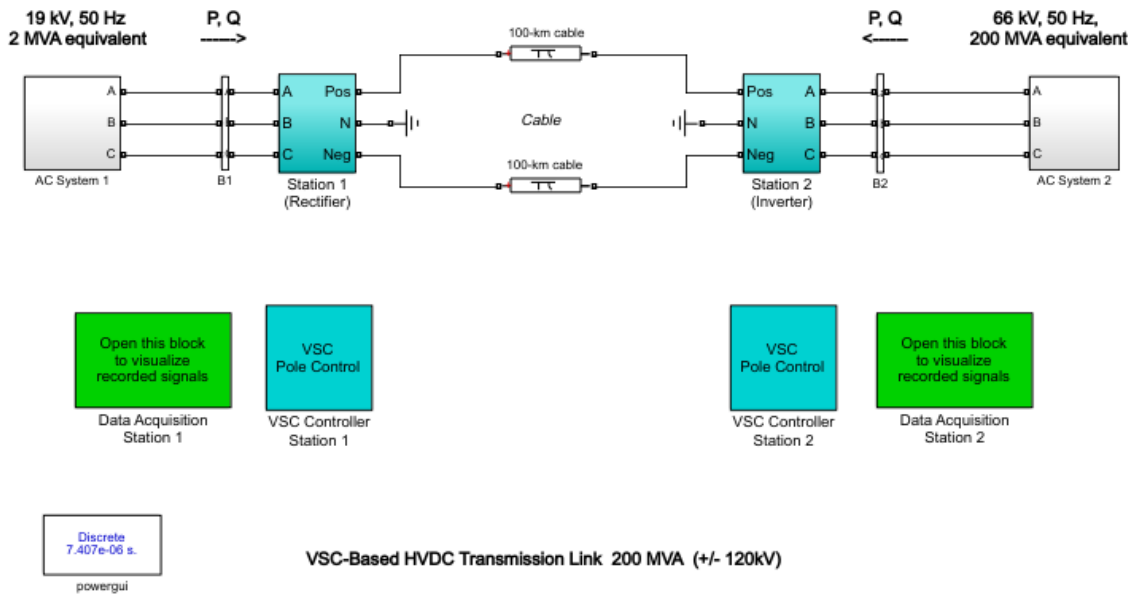
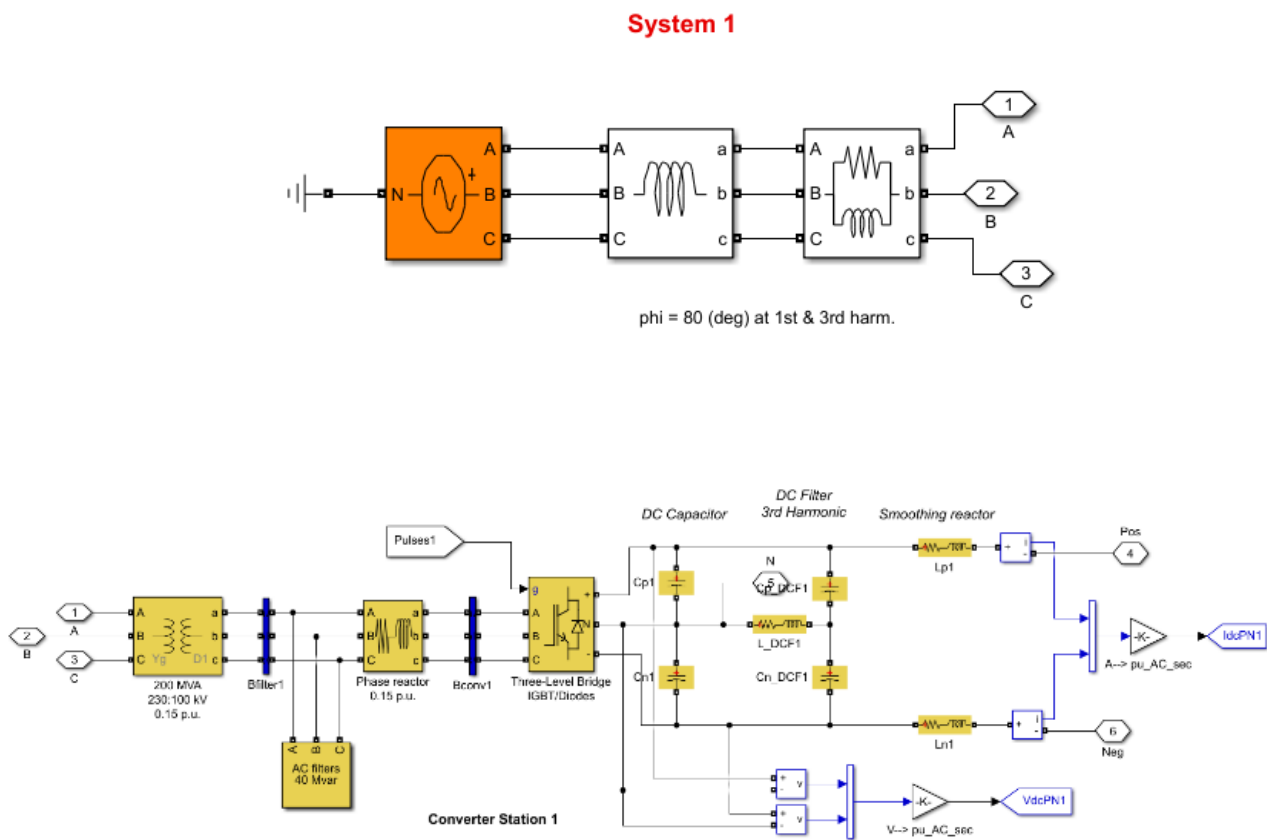

Figure 3.1: Block Design of VSC HVDC Transmission Link

### 3.1.1 VSC HVDC System Configuration

A system on the other hand, is a set of interacting and interdependent entities, either real or abstract that form an integrated whole in of different elements producing results unobtainable by the elements and provide for an accurate interpretation. In a VSC HVDC system there are two converter stations developed with VSC topologies. The converter stations are controlled by sinusoidal pulse width modulations with filters on the AC side to reduce the content of harmonics flowing in the ac system. Figures 3.2 and 3.3 illustrates the rectifier and inverter arms respectively, of the VSC HVDC system.



**Figure 3.2: Rectifier Arm of the VSC HVDC**



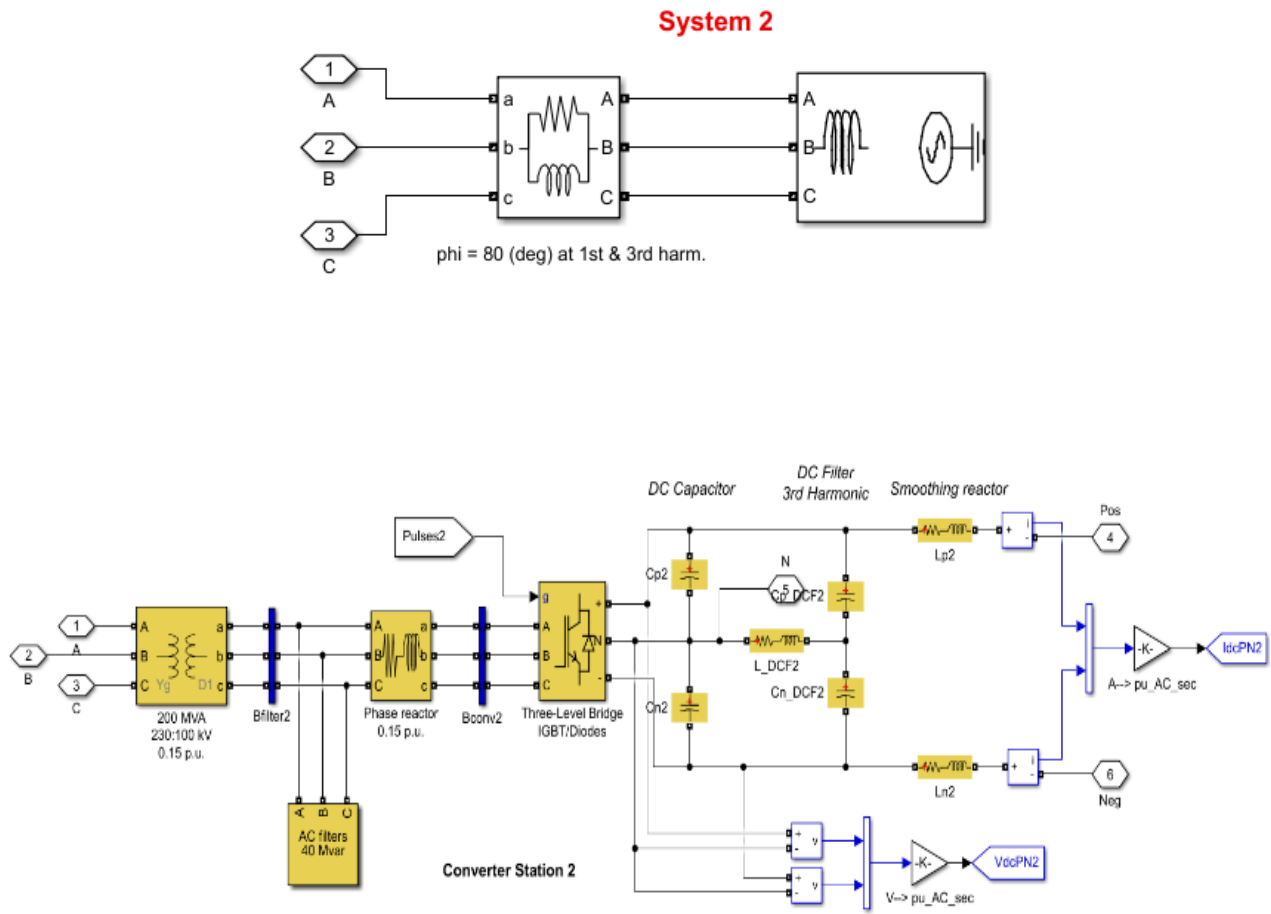

**Figure 3.3: Inverter Arm of the VSC HVDC**

Since one voltage is generated by the AC system and another by the VSC voltage, the relationship between the active and reactive power at the fundamental frequency is defined as follows:

$$P = ((V_s \sin \delta) / X_L) V_r \quad (3.1)$$

$$Q = ((V_s \cos \delta - V_r) / X_L) V_r \quad (3.2)$$

Where  $\delta$  is the phase angle between the real and source voltage. However, at the interconnection of the two AC voltage the above expressions assumes that the reactor is lossless which in reality is false.

### 3.2 Simulation Flow Chart

Figure 3.3 illustrates the steps involved in simulating the VSC HVDC link.

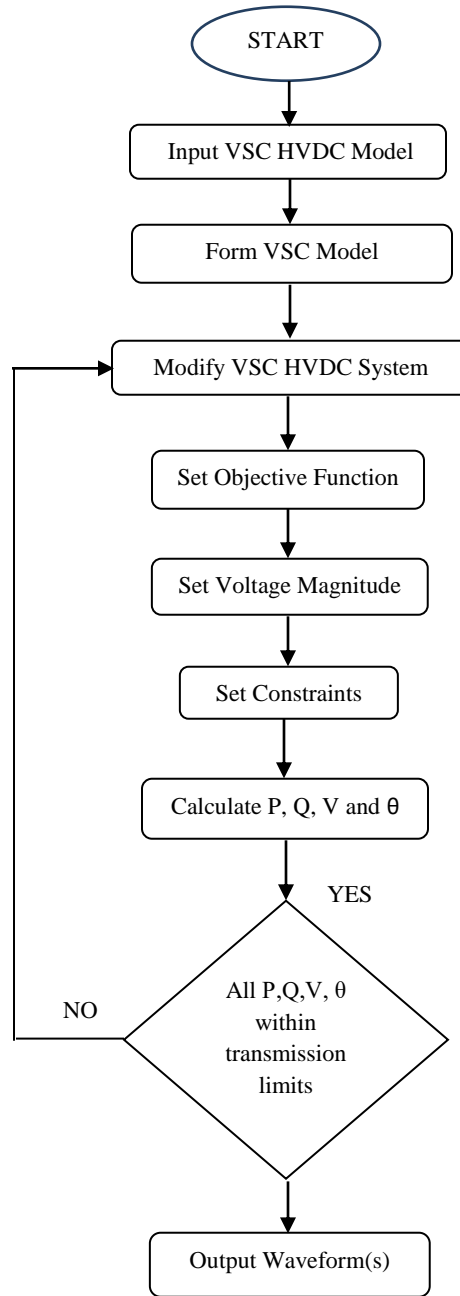

**Figure 3.4: Steps to the Simulation Process Flowchart**

The simulation cycle of the VSC HVDC link went through a series of steps (see figure 3.4). These steps are briefly described as follows:

**Step 1:** Initializing the program and ensuring the version of MATLAB/SIMULINK was the most competitive in terms of user-friendliness. The research adopted version R2019b.

**Step 2:** This is the VSC HVDC link model for ease of comprehending and appreciating its existence from a physical system.

**Step 3:** VSC HVDC links are of various types. Since the research adopted the two-level converter this became the specific VSC type that was simulated with system values. Other forms VSCs in existence are three level converters, Neutral Point Clamped Converters (NPC) and the Modular Multilevel Converter (MMC).

**Step 4:** Following from Step 3, the VSC was modified with the conceptualization of a wind power plant that feeds into an AC network, after undergoing conversion through a wind energy conversion system. The conversion to DC was for convenience in long distance transmission whereas the inversion from DC was to make the supply consistent with industrial, commercial and domestic specification.

**Steps 5& 6:** These guided on how the active and reactive power was regulated for the correct proportionality of the phase angle difference.

**Step 7& 8:** Constraints took into account barriers towards achieving power balance. Even though, these were considered negligible in practice they ought to be taken into account. It then follows, upon satisfying the power balance constraint that calculation of values for real and reactive power, phase angle and voltage were carried out to ascertain that they are within the range of transmission limits. If no, the simulation cycle would revert to Step 4.

**Step 9:** In this last step, and upon adherence to the limits of transmission that the output waveforms are observed, if the waveforms are adequate then the simulation nearly depicts a physical system and thus wind power integration and transmission demonstrated.

### **3.3Chapter Conclusion**

The VSC HVDC link was simulated in a MATLAB/SIMULINK environment. The renewable energy source contemplated was a wind power plant which was fed into an AC network after conversion from DC. Transmission over extended distances was through DC which was later inverted into an AC system as is consistent with industrial, commercial and domestic practice. SIMULINK generates block diagrams for power system simulations a real task-saver from innumerable lines of code. The output waveforms demonstrated the plausibility of integration and transmission of renewable energy. Irrespective of the choice of RE or a mix thereof integration and more so RET can be exploited to accommodate the abundance of RE generation presently in the offing.

## Chapter Four: Results, Discussion and Analysis

### 4.0 Introduction

This chapter presents the simulation results of VSC in HVDC applications. Discussions and analysis as elaborated assists in understanding the behaviour of the VSC-HVDC system given its fundamental functionalities and properties. The MATLAB/SIMULINK simulation software was used in modelling the transmission link of which the results obtained were expected to validate VSC HVDC's practical application with renewable energy.

### 4.1 VSC System Description

Figure 4.1 illustrates a two-terminal VSC-HVDC transmission link. It is observable from there are two converter stations – left-hand and right-hand side converters, representing the rectifier and inverter stations respectively. The VSC converter stations were connected to two AC nodes of the same system – one AC node on the left and the other on the right with a section of a very long transmission overhead cable in between. Additional description of the system were as follows:

The electrical power harnessed from wind upon conversion from DC to AC via a wind energy control system (WECS) is fed into an existing AC transmission network through the rectifier arm which converts the AC to DC thereafter DC to AC conversion at the inverter arm prior to subsequent distribution via an AC network.

Additional key parameters were as follows:

- i) The WPP was rated at 2MVA
- ii) Synchronous Generator 10MVA via 13.8/62.5KV 3phase transformer
- iii) DC System Voltage 120KV
- iv) DC Cable Distance 100km
- v) Current was set at 0.18kA
- vi) Rectifier and Inverter Capacitance was 500 $\mu$ F each
- vii) AC System Voltage 19 kV

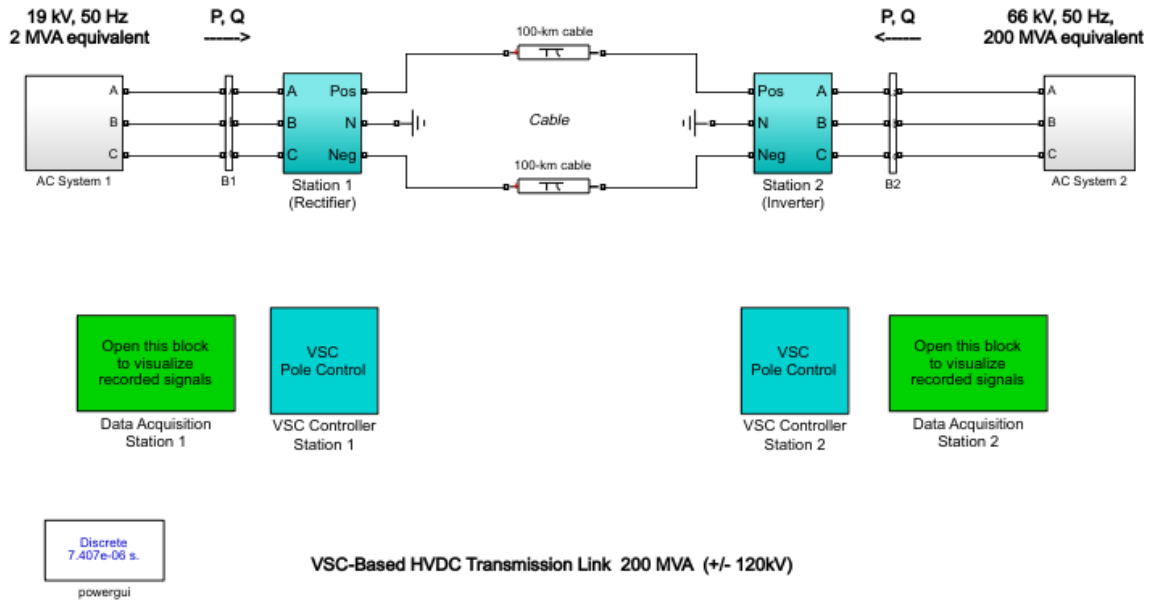

**Figure 4.1: VSC HVDC Transmission Link**

The interface points between the VSC stations and the adjacent AC systems on either side are the Points of Common Coupling. These two interface points where the AC systems connects to the inverter VSC station controls the flow of active power and the rectifier station controls the voltage to a predetermined value; and each station independently regulates its own exchange of reactive power.

Therefore, increasing the transmission capacity (desired power flow exchanges) can be injected at the phase reactors where the VSC station interfaces with the main valves of the converter transformers.

#### 4.1.1 Rectifier Control Station

Figure 4.2 illustrates the simulated control station for DC voltage manipulation and regulation as implemented in the MATLAB/SIMULINK software using per unit values.

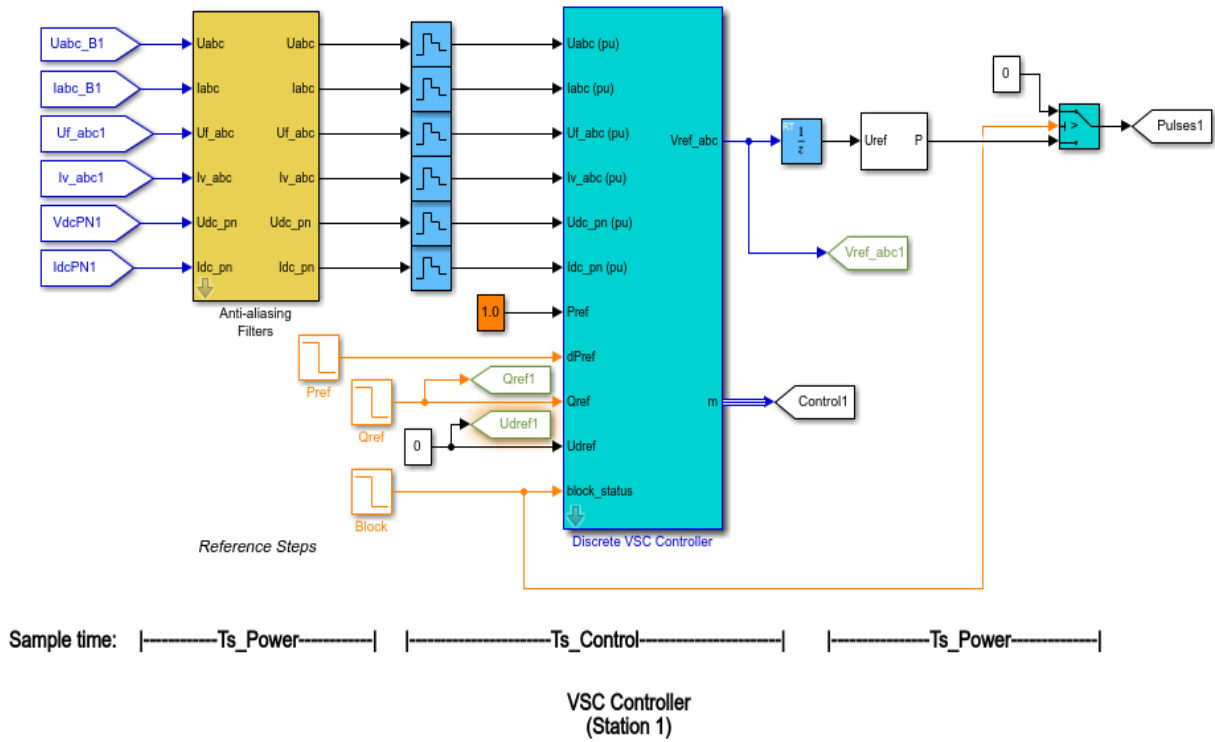

**Figure 4.2: Schematic layout of Rectifier Control Station**

The converter switching frequency ( $f_{CS}$ ) was set 2 kHz from this value we derive the mean converter time delay ( $T_{mean}$ ) from the following expression:

$$T_{mean} = (2 \times f_{CS})^{-1} = (2 \times 2 \times 10^3)^{-1} = \mathbf{250 \mu s} \quad (4.1)$$

Using a time constant,  $\tau = 3ms$  alongside the system description, the DC-link capacitance is calculated using the following expression:

$$C = (2 \tau P_{VSC}) / (U_{cabc}^2) = [2 \times (3 \times 10^{-3}) \times (10 \times 10^3)] / (120 \times 10^3) = \mathbf{500 \mu F} \quad (4.2)$$

We observe from equation 4.2 that the calculated DC link capacitance indeed corresponds to the simulated capacitance of the transmission link in figure 4.1. Thus, effective total capacitance is 1000  $\mu F$  and grounded at their respective junction nodes.

### 4.1.2 Base Parameters

Base parameters helps in simplifying how complex power is analysed. These parameters often expressed per unit (p.u) also aid in simulating the design of VSC transmission link. The determination of base parameters is as expressed in equation 4.3 below:

$$\text{Quantity (p.u)} = \text{Base Parameter Quantity} / \text{Value of Base Parameter Quantity} \quad (4.3)$$

The base parameters converted per unit for modelling were as indicated in Table 4.1

**Table 4.1: Base Parameter and Description**

Base Parameter	Base Parameter Description
$V_{d,b}$ & $V_{q,b}$	Voltage in the dq coordinate system
$I_{d,b}$ & $I_{q,b}$	Current in the dq coordinate system
$Z_{DC}$	DC side impedance
$S_{DC}$	Apparent power DC side
$I_{DC}$	DC side current
$Z_n$ & $S_n$	Representation of rated impedance & apparent power
$V_n$ & $I_n$	Representation of rated voltage & current
$V_{DC}$	DC side voltage
$Z_{DC}$	DC side impedance

From table 4.1 the base parameters were converted as per equations 4.4 below:

$$\begin{aligned}
 V_{d,b} = V_{q,b} &= \sqrt{(3/2)} V_n \\
 I_{d,b} = I_{q,b} &= (\sqrt{2}) I_n \\
 S_{d,b} &= 2/3 * S_n \\
 Z_{d,b} = V_{d,b}/I_{d,b} = Z_n &= V_n/(\sqrt{3} * I_n) \\
 S_{DC} = S_n = 3/2(V_{d,b} I_{d,b}) &= \sqrt{3} V_n I_n \\
 I_{DC} = S_{DC}/V_{DC,b} = 0.75 I_{d,b} &= (3\sqrt{2}) 4 I_n
 \end{aligned}
 \quad (4.4)$$



$$Z_{DC,b} = V_{DC,b}/I_{DC,b} = (8/3)Z_{d,b} = 8/3Z_n$$

Base Parameter Values are derived as follows:

$$V_{d,b} = \sqrt{(3/2)} V_n = \sqrt{(3/2)} * 19 = \mathbf{23.27 V}$$

$$I_{d,b} = I_{q,b} = \sqrt{(2)} I_n = \sqrt{(2)} * 0.18 = \mathbf{0.25 kA}$$

$$S_{d,b} = 2/3 * S_n = 2/3 * 10 = \mathbf{6.67 MVA}$$

$$Z_n = V_n / \sqrt{3} I_n = 19 / \sqrt{3} * 0.18 = \mathbf{60.9 \Omega}$$

$$Z_{d,b} = V_{d,b}/I_{d,b} = 23.27 / 0.25 = \mathbf{93.08 \Omega}$$

$$I_{DC} = S_{DC}/V_{DC,b} = [(3\sqrt{2})/4] * I_n = [(3\sqrt{2})/4] * 0.18 = \mathbf{0.19 kA}$$

$$Z_{DC,b} = V_{DC,b}/I_{DC,b} = (8/3)Z_{d,b} = 8/3Z_n = \mathbf{162.4 \Omega}$$

### 4.1.3 Rectifier Arm Analysis

Figures 4.3, 4.4, 4.5, 4.6, 4.7 and 4.8 are graphical signals from the acquisition station of the rectifier arm given the topology of VSC used. Basically, the type of topology determines the creation of the AC waveform and DC voltage. This research aligned with the two-level topology since it is still commercially very competitive for small to medium size power applications. A two-level converter switches between  $+v_{dc}$  and  $-v_{dc}$  as shown in ordinate axes of the mentioned figures. Given the choice topology, the AC waveforms are created using PWM (Pulse Width Modulation).

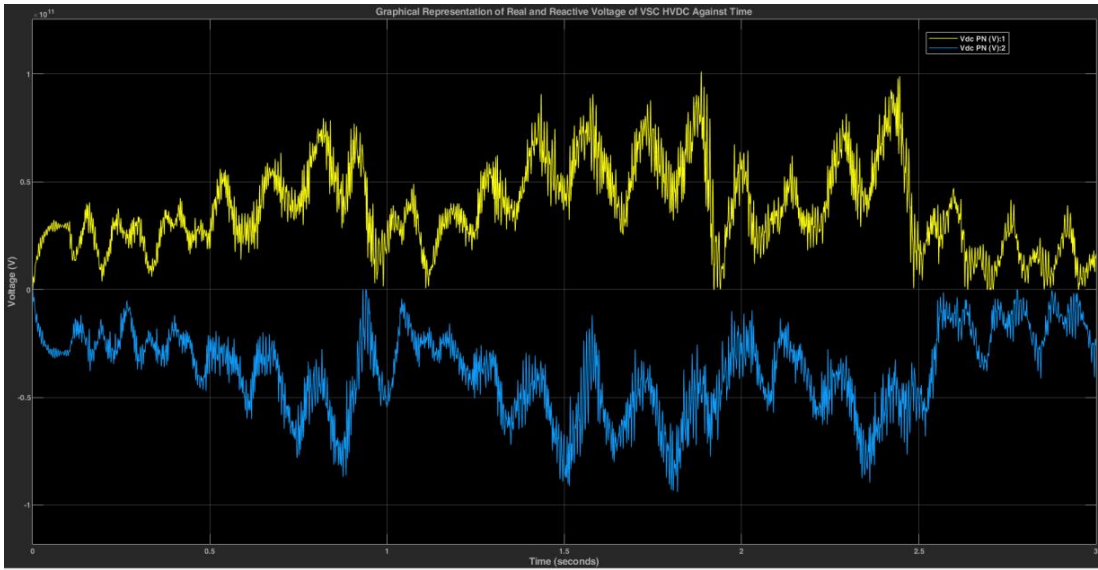

**Figure 4.3: Graphical Representation of Real and Reactive Power of VSC HVDC against time**

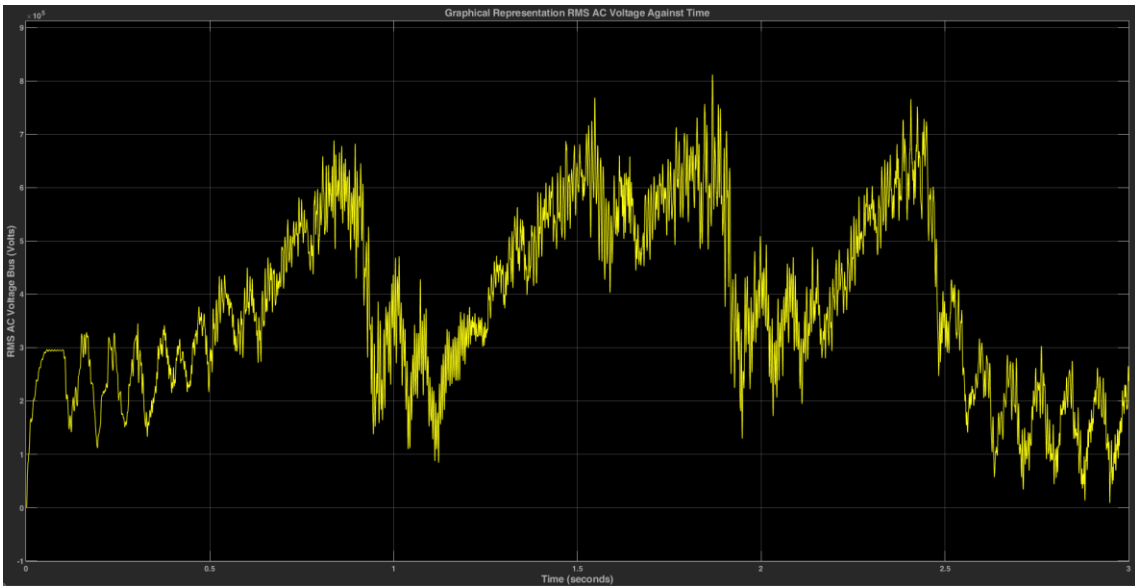

**Figure 4.4: Graphical Representation of RMS AC Voltage against time**

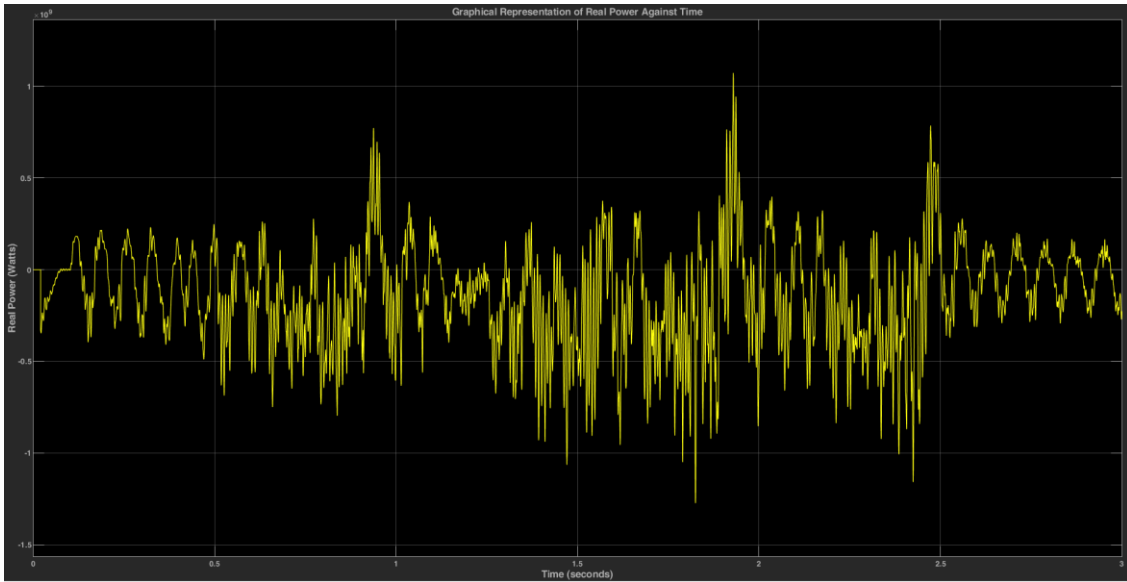

**Figure 4.5: Graphical Representation of Real Power against time**

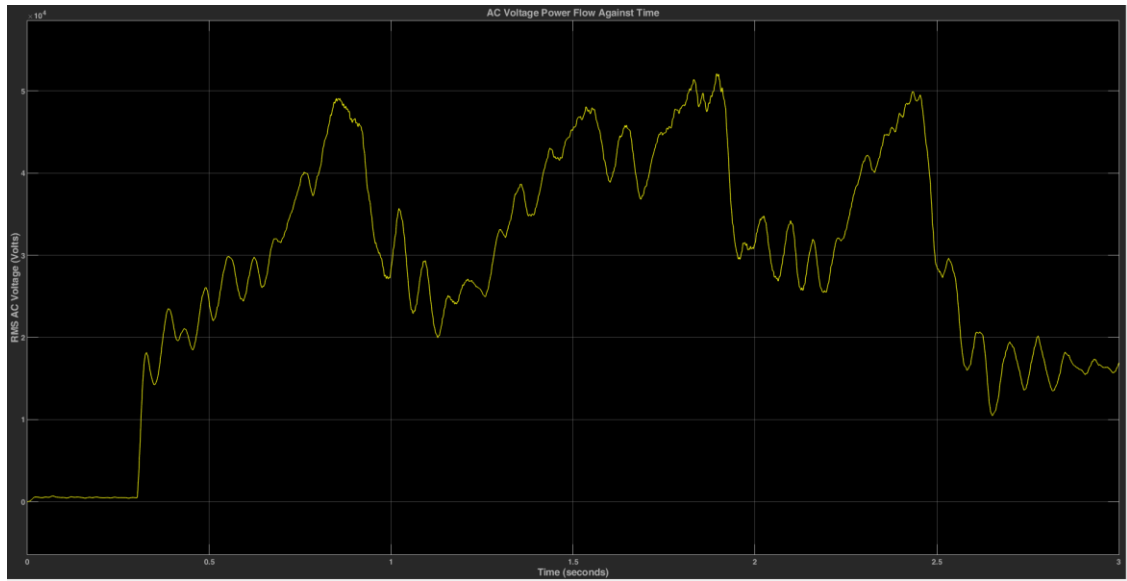

**Figure 4.6: Graphical Representation of AC Voltage Power Flow against Time**

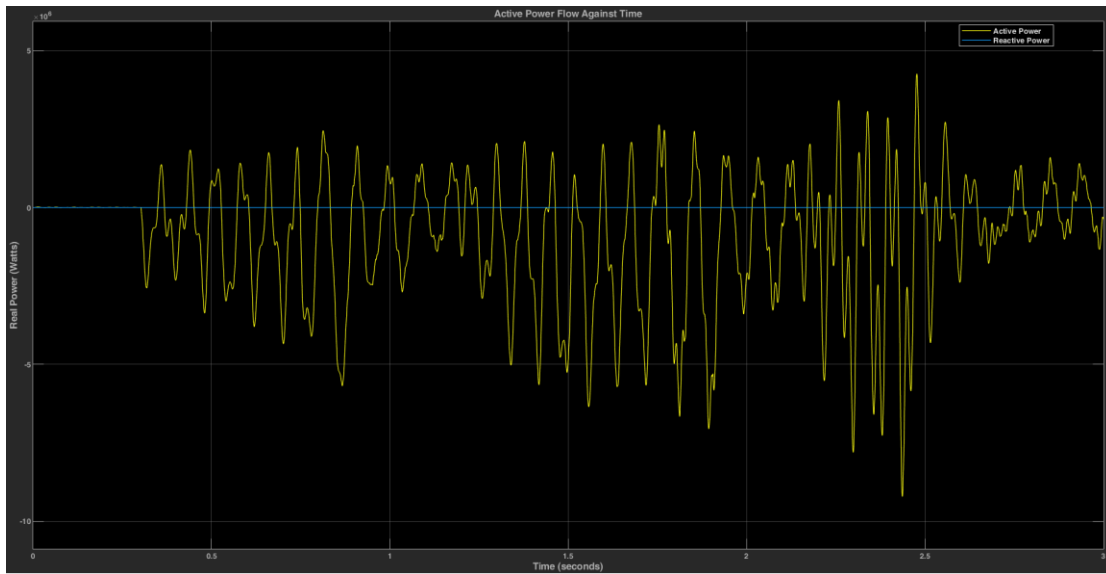

**Figure 4.7: Graphical Representation of Active Power Flow against Time**

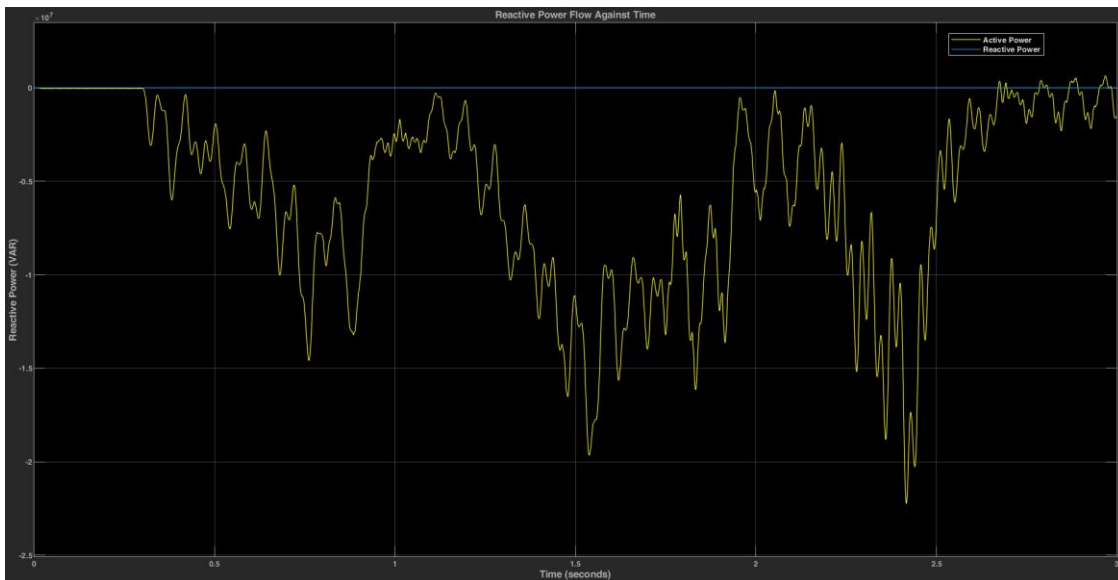

**Figure 4.8: Graphical Representation of Reactive Power Flow against Time**

In order to obtain a smooth AC voltage waveform as shown in figure 4.9, filtering is needed to reduce or filter out the high order harmonics. The AC filters which are connected in parallel between the transformer and phase reactor, acts as low pass filter to create a smooth AC voltage waveform from the

high frequency PWM voltage. This AC voltage waveform is what will enable the flow of active and reactive power.

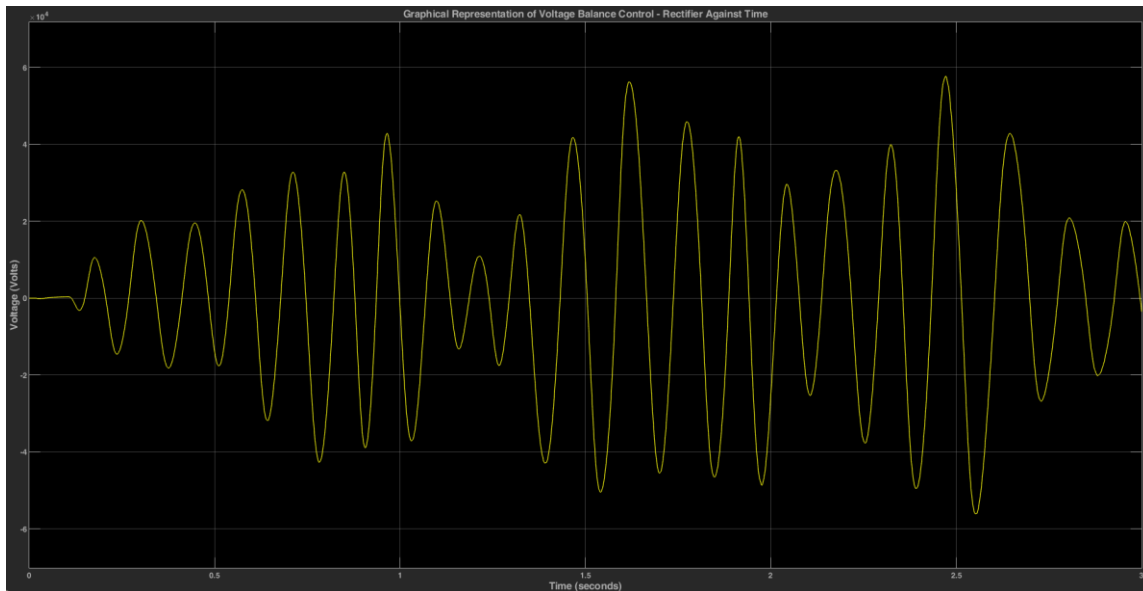

**Figure 4.9: Graphical Representation of Voltage Balance Control Waveform (Rectifier Side)**

The voltage phase angle of the fundamental frequency when changed across the phase reactor controls the active power whereas the voltage magnitude of the fundamental frequency when changed in like manner goes to control the reactive power. Thus, when the rectifier station is connected to another receiving station (inverter) a transmission link is conceived, in principle a VSC HVDC transmission link.

## 4.2 Inverter Analysis and Grid-side Synchronization

To avoid duplicity Appendix C contains the inverter side figures and graphs. But, an important to note that the inverter side controls the flow of active power, and the control and signal acquisition station and observable graphs will more or less be identical to the rectifier side, since principally the rectifier mirrors the inverter.

Another critical role handled by the inverter arm is that of synchronizing the power to be delivered with the grid. Figure 4.10 shows the AC voltage waveform of the inverter side. As it will be observed this waveform is a tad smoother when contrasted with the AC voltage waveform of the rectifier side.

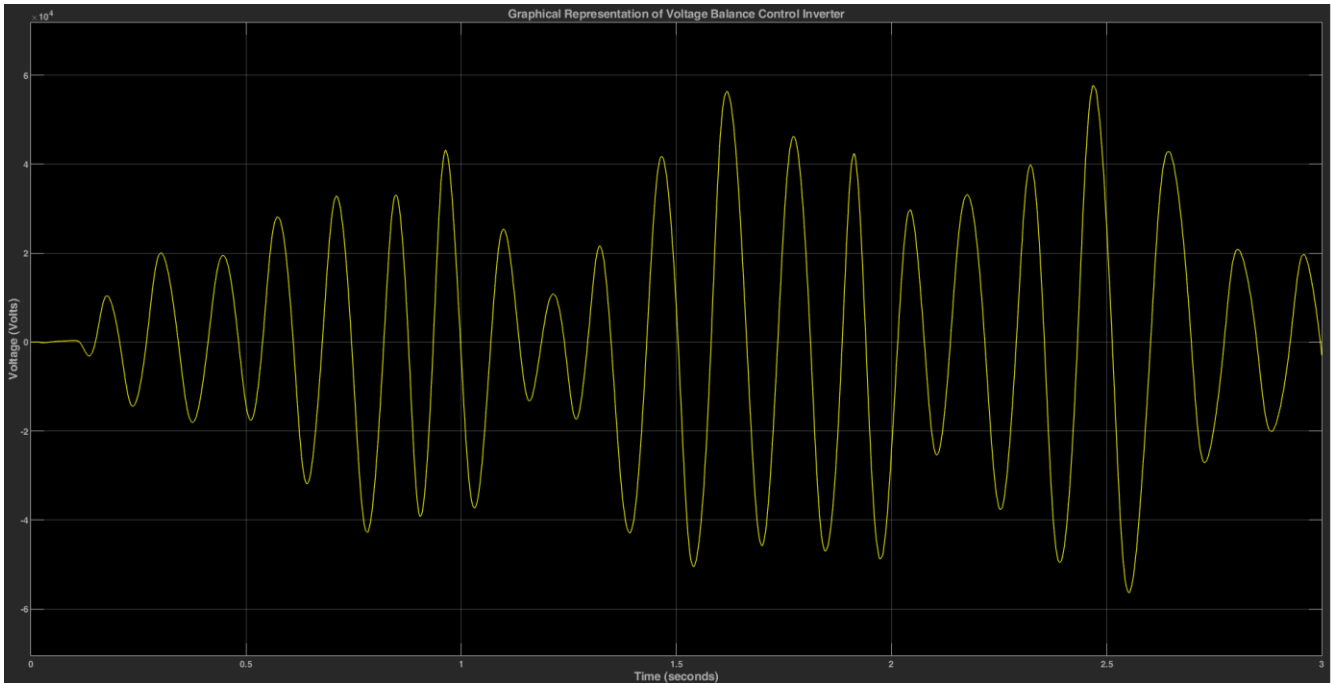

**Figure 4.10: Graphical Representation of Voltage Balance Control Waveform Inverter Side**

The grid side control system detects the voltage phase angle of AC System 2 and matches this profile with the AC voltage waveform created at the inverter side for the synchronous delivery of power. The grid side inputs are the phase voltages whose phase angles are monitored on a continuous basis for the desirous phase angle compatible for the grid.

Figure 4.9 is the inverter side control system and electrical layout of components. Clicking on each component reveals their respective ratings. The MATLAB/SIMULINK software used for simulation generated the schema but perhaps what is noteworthy in the entirety of the illustration below is the proportional integral controller – its role in achieving the desired pulse.

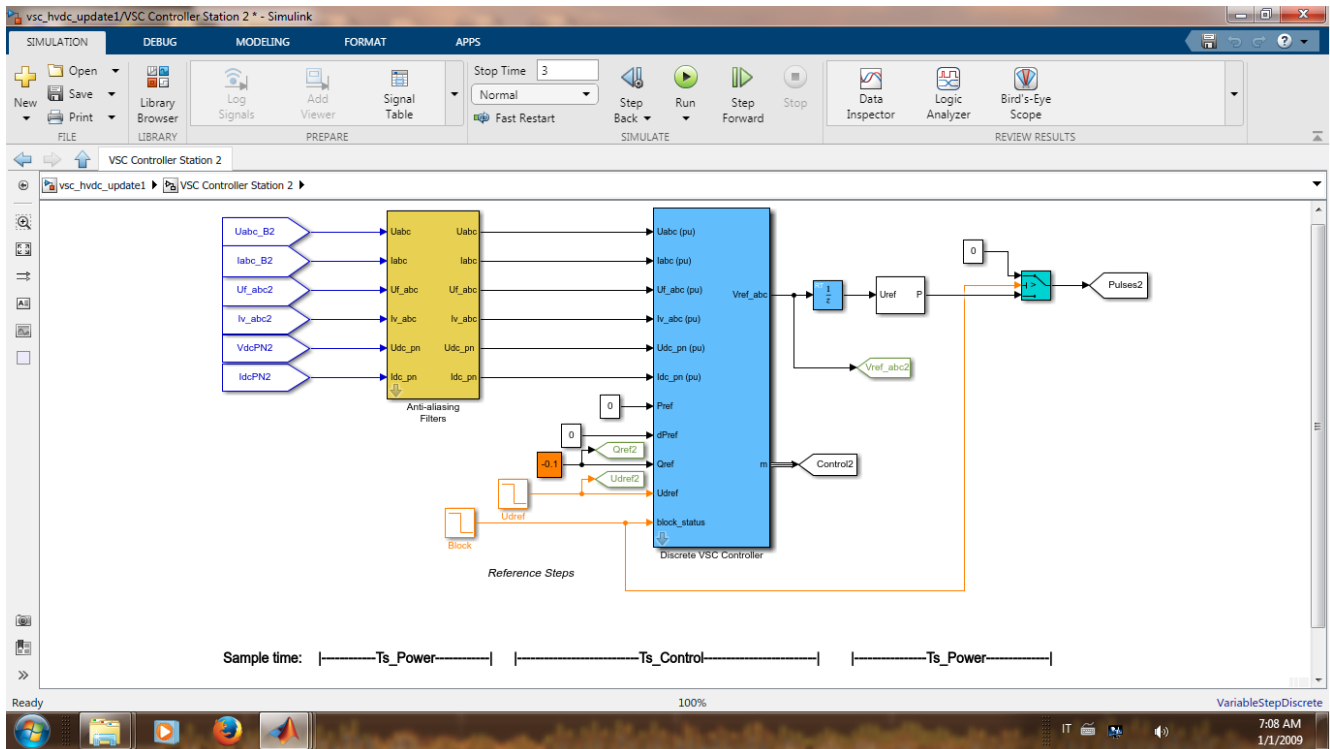

**Figure 4.11: Inverter Side Control System**

### 4.2.1 Error in Grid Pulse

In the event of a deviation, when the obtained pulse is differs from the desired output there is a feedback mechanism in the inverter VSC controller that monitors the deviations. It will compare the pulse from the feedback with the target (desired) pulse set at the grid side. The PI controller, a composite of proportional and integral control modes, clears proportional mode offsets whereas the integral part of the mode provides the reset on the output on error in the event of a change in load. Proportional mode only means there is a linear existence in the relationship between the output from the inverter and the error. Therefore, the immediate response because of action that is in proportion to the error is eliminated by the integral action whose response to the error is as a function of time.

### 4.3 Transmission Expansion Analysis

The rationale of expanding transmission using existing infrastructure is a least-cost approach to meeting the demand of power with fewer environmental constraints in comparison to new line constructions. However, this data was onerous to obtain besides there are few instances of its

implementation. Thus, the analysis will proceed with technical considerations prior to transmission expansion. These considerations are:

- i) The intended capacity of power to be transmitted. Insulator string replacement attracts a much lower cost than conductor replacement. Changing conductors yields a higher ampacity. However, this type retrofit is subject to the structural competence of the tower;
- ii) Network System Configuration. At best, the new configuration should be one that has less to zero redundancy;
- iii) Structural and mechanical competence of the existing tower should be verified;

The technical constraints for transmission line conversion are:

- i) Conductor thermal limit determines the amount of power that will be transmitted;
- ii) Corona phenomenon which impacts the HVDC operating voltage. Corona is when the air in between the conductors is ionized leading to leakage of current;
- iii) The existing right of way determines the electrical field at ground level against the audible noise. However, this constraint is more often taken into account when the line conversion includes modification of the tower structure

Formulating alternatives  $k$  from equation 2.12 for transmission line  $i$  each alternative is represented as  $CONV_{i,k}$  and the power obtained from the conversion of choice ought to be more than the maximum HVAC load plus the unsupplied demand (DNS).

$$P_{CONV_{i,k}} > i_{Lmax} + DNS_n$$

The alternative with the least impact on unsupplied power during the line modification period.

#### **4.4 REI Economic Analysis**

Economic Analysis for the integration of renewable energy into the transmission grid is essential because investments in renewable energy require significant investments in capital. Of all RES wind is most cost effective as its usage reduces significantly the cost fuel. Figure 4.11 shows the wind resource of Kenya with close to three-quarters of the land spaces falling under Class 4 of the Beaufort scale (areas shaded in green) at a height of 100 meters.



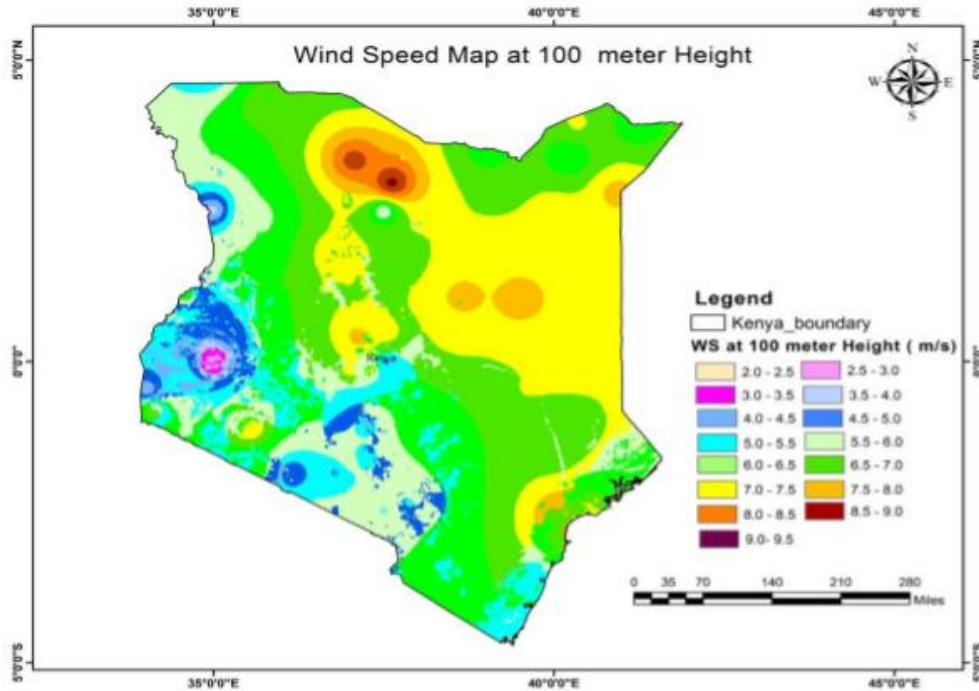

**Figure 4.12: The Wind Resource Map of Kenya [12]**

The economic comparison of generating electricity from RES vis-à-vis conventional modes is usually arrived at by contrasting and balancing the high RE investment cost from the conventional generation costs plus the fuel operation costs over the long term. Weighing generation alternatives is determined by the Levelized Cost Of Energy (LCOE) based on the period of investment, capacity, lifetime operations and finance. This metric makes use of a discount rate when assigning the life-cycle costs to every amount of energy generated. Other essential parameters besides generation and initial costs include operation and maintenance, production of electricity, lifetime and running costs.

#### **4.5 Validation**

The solution addressed in this research is renewable energy integration using HVDC, more precisely with VSC technology. And, the mode of power transmission is via overhead cables – a low power strategy under relatively much shorter distances ideal for metropolitan centres and towns. However, the only overhead VSC line is Namibia’s Caprivi link HVDC interconnector that connects Namibia to Zambia through a 350kV overhead line at a distance of approximately 950km. Having been in

operation for almost a decade, this link mainly is for strengthening the AC system. It is yet to be established if the link will in the near future transmit RE power.

Contrasting the Caprivi Link with the tenets of this research renewable energy will be a vital component of electricity generation and transmission where it is proposed in this research a model that can also be used for towns and metropolitan centres. These cities and centres will influence the electrical future given their abundance of consumption and utilization of electrical energy on one hand while cutting dependence on fossil fuels on the other. Furthermore, being adaptable to both wind and solar sources.

Worldwide, the maximum voltage on VSC HVDC is approaching the 1 000kV mark with power almost averaging 3 GW all projects considered cumulatively. Attributes such as small lands for right-of-ways, small transmission tower sizes and driving loads non-dependent on reactive power requirements are desirable when conceptualizing VSC HVDC for metropolitan areas. However, due to the reduced appetite on constructing new transmission lines this research adopted a two-pronged approach of retrofitting an aged AC line to DC with the aim of increasing transmission capacity; then making the transmission line compatible with renewable energy – a relatively new concept towards renewable energy integration.

#### **4.6 Chapter Conclusion**

The simulation of VSC HVDC transmission link was done and demonstrated successfully. Wind power was treated as an AC source side by side with the grid power, this was after taking into account the necessary conversions required to change the natural characteristic of wind from DC to AC.

The desired voltage to be transmitted through the link was measured and controlled between the phase reactor and the ac-side filters. The active power realised is what was conveyed through the VSC HVDC link. This active power was higher than the initial carrying capacity of the former HVAC line signalling a gain in transmission capacity.

All possible losses were considered, and the final output voltage waveform was the expected sinusoid. Challenges were however encountered when suggesting a retrofit to HVAC line thus there was not

sufficient data to support a cost comparison between original construction of a HVDC line against HVAC retrofit to HVDC as proposed in the research.

## **Chapter Five: Conclusions and Recommendations**

This chapter summarizes the works of research around the integration of renewable energy by attempting to suggest guideposts for future undertakings towards the prudent positioning with respect to the demands and supply of energy for the future.

### **5.1 Conclusions**

In this research, the objective was to examine the role HVDC transmission systems in evacuating renewable energy for medium to low-scale power applications. It explored the insulated gate bipolar transistor technology to leverage a forward-looking medium-term power solution for densely populated settlements and metropolitan centres. Consequently, a transmission link was simulated on MATLAB/SIMULINK environment that demonstrated wind power evacuation using voltage source converters by exploiting the positive HVDC attributes and making the most of these attributes for shorter distances – where HVAC would thrive.

Conventional AC lines giving way to increased energy demands and advancement of more robust technology, could upon meeting a certain criteria have the mode of transmission changed from AC to DC and an increase in transmission capacity changed as a result. Even though the lifetime to this approach can only buy some time, computed as a couple of decades, the much longer term electric infrastructural investment lies with smart grids which requires a longer range planning and implementation. Data supporting AC to DC retrofits was not readily available since the concept of ameliorating conventional and critically loaded AC lines is relatively new.

Nevertheless, the simulation, testing and approach proffered was seen to be practicable in a number of contexts when the exploitation of renewable energy is taken into consideration.

## 5.2 Recommendations for Future Works

Future work that could enhance the findings of this research could be:

- i) The consideration of solar as an energy source. This research focused on wind, but also the solar has quite an impressive abundance which could be considered and subsequently, once harnessed, transmitted and distributed in populated centers.
- ii) Exploration of other life extension techniques for aged or aging AC lines. This research considered reconductoring with HVDC which in turn could increase the current capacity. Other forms could be explored.
- iii) Robust energy storage. Renewable sources of energy require a technology that can transmit power generated from renewables but the major constraint has been the grid. Thus, additional work can be apportioned on how a grid can be supported to enable integration and reliable transmission of large-scale renewable energy.

## References

- [1] A. K. Alsaif “Challenges and Benefits of Integrating the Renewable Energy Technologies into the AC Power System Grid” American Journal of Engineering Research (AJER) Vol. 6, No. 4, pp-95-100 (2017)
- [2] A. Rajapakse, D. Muthumuni and N. Perera “Grid Integration of Renewable Energy Systems” University of Manitoba, Manitoba HVDC Research Centre, Manitoba, Canada, pp 110-130 December 2009
- [3] E. Fernandez, I. Albizu. M. Bedialauneta, A.J. Mazon, P. Asano “Review of Dynamic Line Rating Systems for Wind Power Integration” Renewable & Sustainable Energy Reviews Vol. 53, pp 80-92 January 2016
- [4] D.M. Larruskain, I. Zamora, O. Abarrategui, A. Iturregi, “ VSC-HVDC Configurations for converting AC distribution lines into DC lines” International Journal Electrical Power Energy Systems 54, pp 589-597 (2014)
- [5] The Renewable and Sustainable Energy Institute, Grid Integration of large-capacity Renewable Energy Sources and use of large-capacity Electrical Energy Storage, Geneva, Switzerland (2012)
- [6] Das D. (2006) Electrical Power Systems, New Age International Ltd
- [7] Z. Li, R. Zhan, Y. Li, Y. He, J. Hou, X. Zhao “Recent developments in HVDC Transmission Systems to Support Renewable Energy Integration” Global Energy Interconnection Vol. 1 No. 5, December 2018
- [8] T. John, W. Tony (2006) Renewable Energy Resources, CRC Press Taylor & Francis
- [9] D.M. Larruskain, I. Zamora, A.J. Mazón, O. Abarrategui, J. Monasterio “Transmission and Distribution Networks: AC versus DC” Department of Electrical Engineering, University of the Basque Country – Bilbao (Spain) Vol. 19, 2007
- [10] Y. Li, H. Liu, X. Fan, X. Tian “Engineering practices for the integration of large-scale renewable energy VSC HVDC systems” China Electrical Power Research Institute, Haidian District, Beijing 100192, P.R. China Vol. 3 No. 2, pp 149-157, April 2020
- [11] G. Xydis Comparison Study between a renewable energy supply system and a supergrid for achieving 100% from RE sources in islands International Journal Electrical power Energy Systems 46, pp 198 – 210 (2013)

- [12] <https://renewableenergy.go.ke/technologies/wind-energy/> Accessed on 28<sup>th</sup> September 2021
- [13] O.E. Oni, K.I. Mbangula and I.E. Davidson “A Review of LCC HVDC and VSC HVDC Technologies and Applications” Transactions on Environment and Electrical Engineering, September 2016
- [14] V.G. Agelidis, G.D. Demetriades, N. Flourentzou “Recent Advances in High Voltage Direct Current Transmission Systems” Proceedings of National Power Electronics Conference of China, pp 23-26, 2006
- [15] O. Saksvik “HVDC Technologies and Smart Grid” 9<sup>th</sup> IET International Conference on Frontier Computing, Hong Kong, January 2012
- [16] Z. Li, R. Zhan, Y.Li, Y. He, J. Hou, X. Zhao “Recent developments in HVDC Transmission to support Renewable Energy Integration” Global Energy Interconnection Vol. 1 No. 5, December 2018
- [17] Y. Cunijiang, Z. Huaxin, Z. Lei, “Architecture Design for Smart Grid” International Conference of Future Electrical Power and Energy Systems Energy Procedia vol. 17, pp 1524-1528, February 2012
- [18] Y. Wang, H. Qiu, Y. Tu, Q. Liu, Y. Ding, W. Wang “A Review of Smart Metering for Future Chinese Grids” CUE 2018 – Applied Energy Symposium and Forum 2018: Low Carbon Cities and Urban Energy Systems, Shanghai China, June 2018
- [19] N. Flourentzou, V.G. Agelidis and G. Demetriades “VSC Based HVDC Power in Transmission Systems: An Overview” IEEE Transactions on Power Electronics, vol. 24, no. 3, pp 595-602, March 2009
- [20] G. Lee, D. Kwon, S. Moon “DC Current and Voltage Droop Control Method of Hybrid HVDC Systems for an Offshore Windfarm Connection to Enhance AC Stability” IEEE on Energy Conversion, June 2020
- [21] M.V Kazemi, A.S. Yazdankah, H.M. Kojabadi “Direct Power Control of DFIG-Based on Discrete Space Vector Modulation” Renewable Energy vol. 35, pp 1033-1042, September 2009
- [22] M. Haddadi, A. Rabiee, S. Nikkah “Location-Based Uncertainty Management of Offshore Windfarms: A Multiple Radius Robust Decision Making” International Journal of Electrical Power and Energy Systems, vol. 136, March 2021

- [23] M. Kapsali, J.K. Kaldellis, J.S. Anagnostopoulos “Investigating the Techno-Economic Perspectives of High Wind Energy Production in Remote versus Interconnected Networks” *Applied Energy*, Elsevier, vol. 173, pp 238-254, April 2016
- [24] R. Shah, J.C. Sanchez, R. Preece, M. Barnes “Stability and Control of Mixed AC-DC Systems with VSC HVDC: A Review” *IET Generation, Transmission and Distribution*, vol. 12, January 2018
- [25] Y. Li, H. Liu, X. Fan, X. Tian “Engineering Practices for the integration of large-scale renewable energy VSC-HVDC Systems” *Global Energy Interconnection*, vol.3 no. 2 pp 149-157, April 2020
- [26] F. Ayadi, I. Colak, I. Garip, H.I. Bulbul “Impacts of Renewable Energy Resources in Smart Grid” *The 8<sup>th</sup> International Conference on Smart Grids*, June 2020
- [27] Y. Liu and Z. Chen “Transient Voltage Stability Analysis and Improvement of a network with different HVDC Systems” *2011 IEEE Power and Energy Society General Meeting*, pp 1-8, July 2011
- [28] E. Ahmed and B.A Elanien “Protection of Star Connected Multi-Terminal HVDC Systems with Offshore Windfarms” *2018 IEEE 12<sup>th</sup> International Conference on Compatibility, Power Electronics and Power Engineering*, pp 1-6, June 2018



## Appendices

### Appendix I: Beaufort Scale

Beaufort scale	Class	Characteristics and impacts	Wind speed		
			m.s <sup>-1</sup>	km.h <sup>-1</sup>	mile.h <sup>-1</sup>
0	Calm	No wind, smoke billowing upright	0-0.2	1	1
1	Light Air	The direction of the wind is visible in the direction of smoke, there is no breeze	0.3-1.5	1-5	1-3
2	Light breeze	The wind felt on the face, the leaves lightly rocked	1.6-3.3	6-11	4-7
3	Gentle wind	The leaves and twigs continue to sway	3.4-5.4	12-19	8-12
4	Moderate wind	Dust and paper blowing, twigs and small branches sway	5.5-7.9	20-28	13-18
5	Fresh breeze	Small trees sway, white foam in the sea water	8.0-10.7	29-38	19-24
6	Strong wind	The big branches swayed, the sounds of the electric wire	10.8-13.8	39-49	25-31
7	High wind	The whole tree rocked	13.9-17.1	50-61	32-38
8	Gale	The branches of a broken tree, walking against the wind are quite heavy	17.2-20.7	62-74	39-46
9	Severe gale	The roof of the house is blown and thrown	20.8-24.4	75-88	47-54
10	Strong storm	Trees are uprooted, houses are severely damaged	24.5-28.4	89-102	55-63
11	Violent storm	Storm damage large areas	28.5-32.6	103-117	64-72
12	Hurricane force	Big trees uprooted, houses collapsed	>32.6	>117	>72

## Appendix II: Inverter Side Signals and Graphs

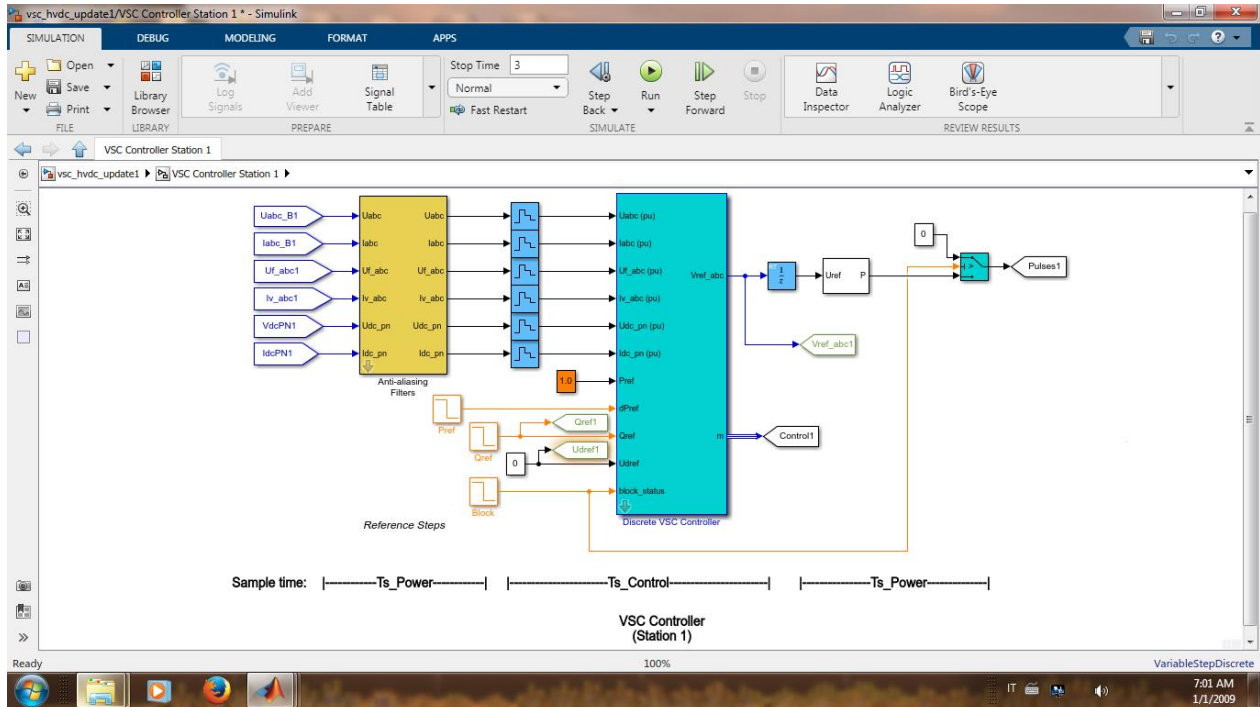

**Figure A1: Rectifier Control System Station**

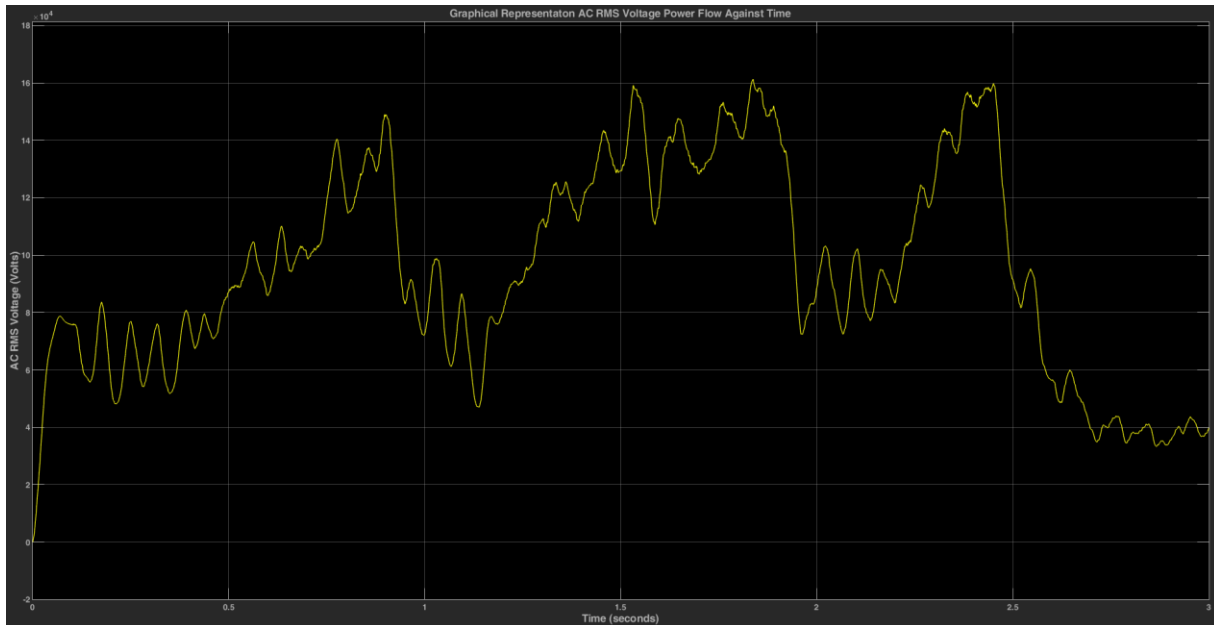

**Figure A2: Graphical Representation AC RMS Voltage Power Flow**

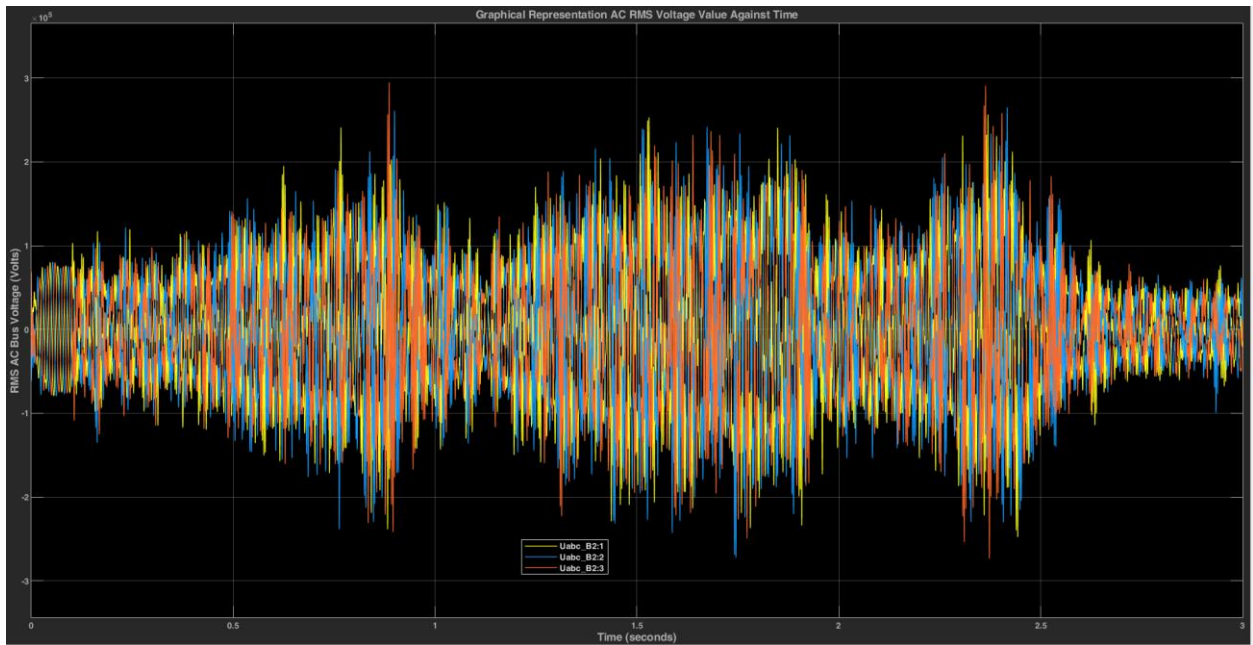

**Figure A2: Graphical Representation of AC RMS Voltage Value**

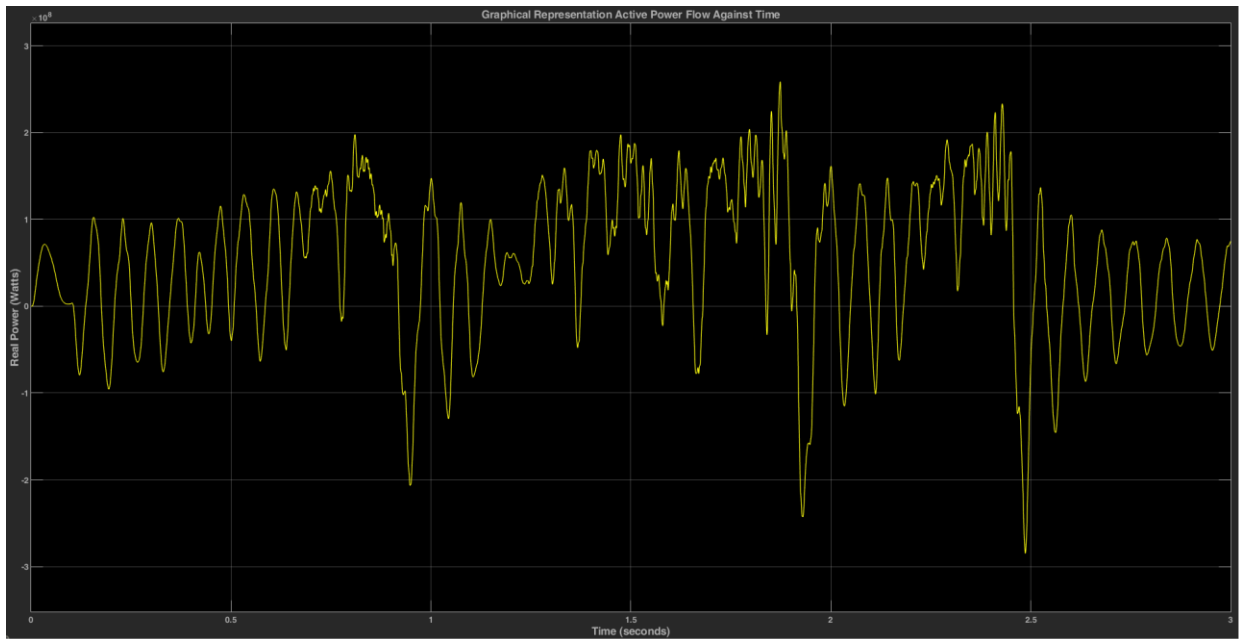

**Figure A3: Graphical Representation of Active Power Flow**

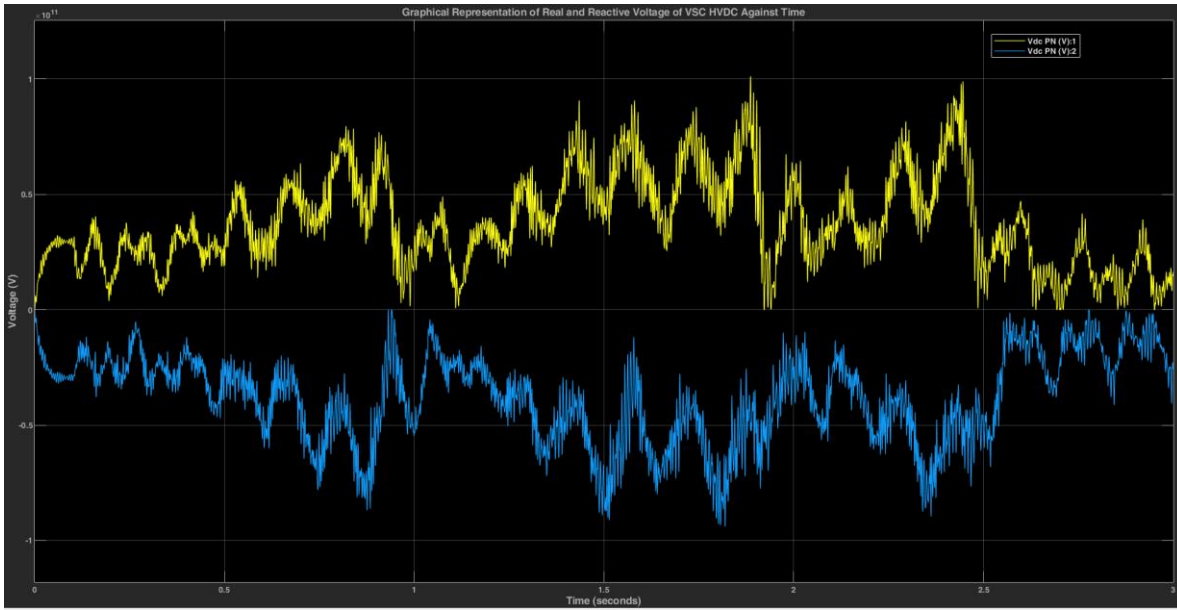

**Figure A4: Graphical Representation of Real & Reactive Voltage**

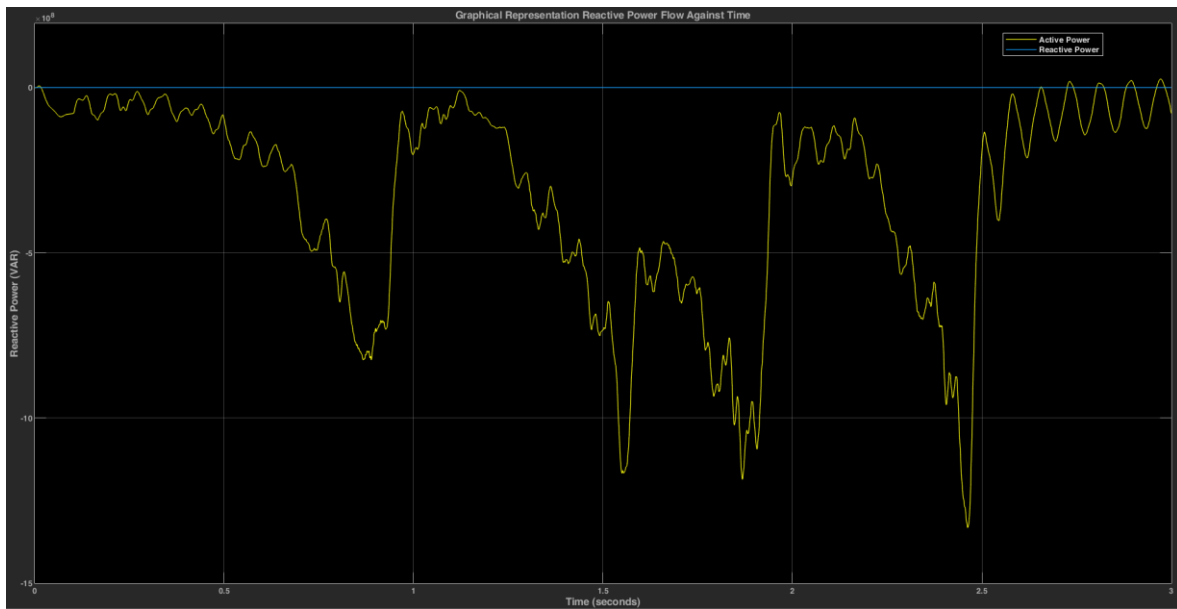

**Figure A5: Graphical Representation of Reactive Power Flow**

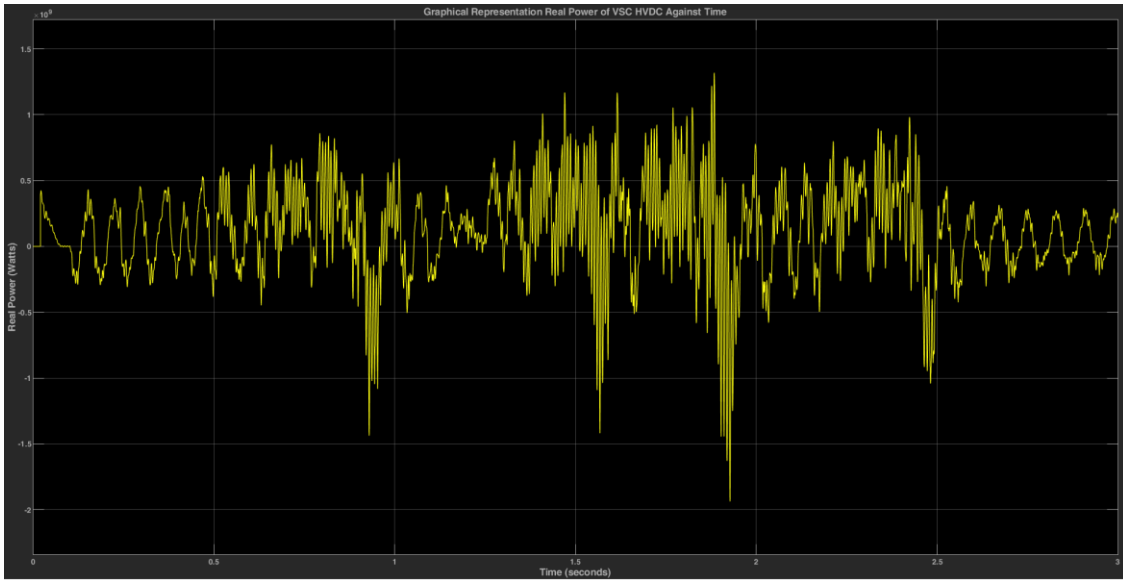

**Figure A6: Graphical Representation of Real Power**

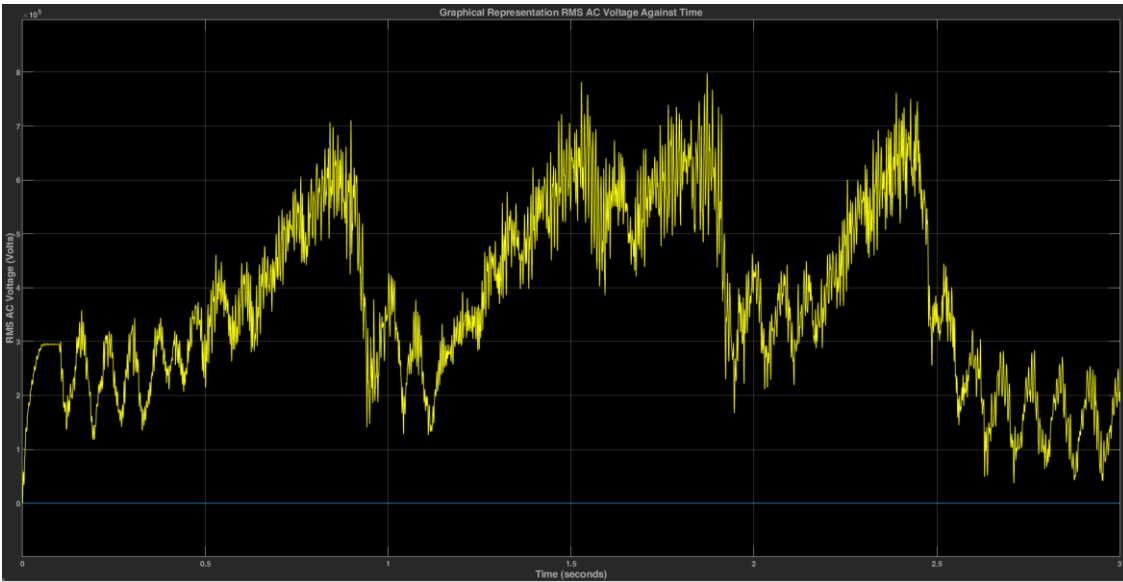

**Figure A7: Graphical Representation of RMS AC Voltage**

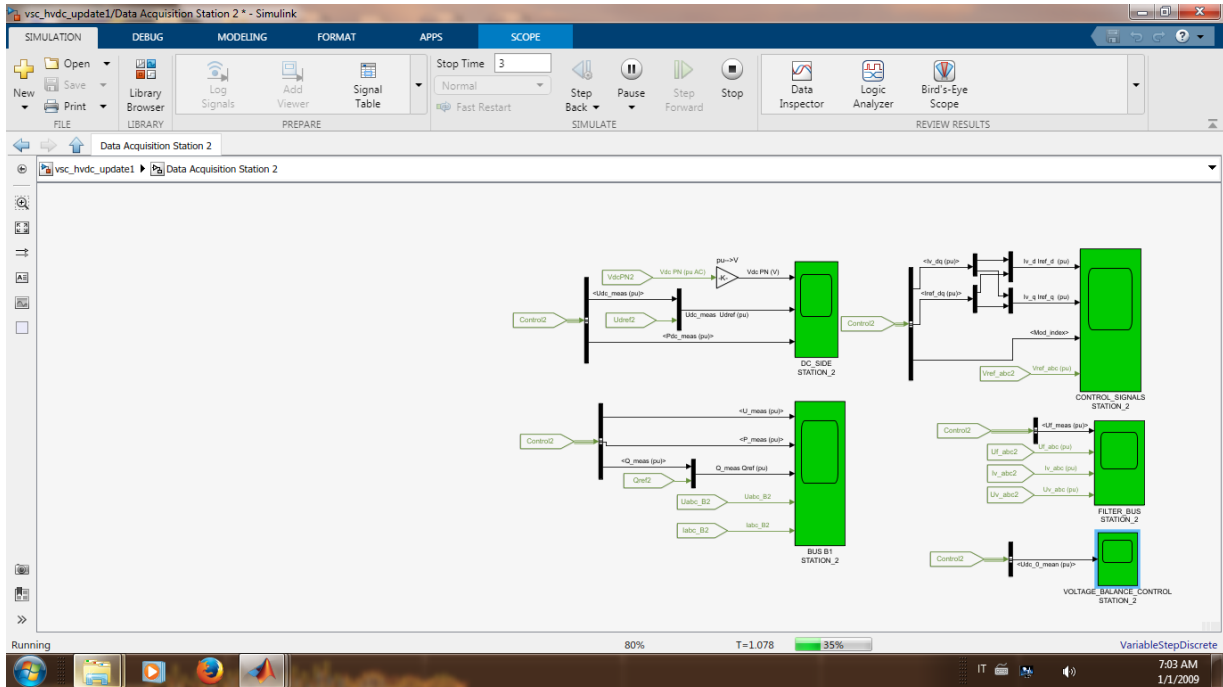

**Figure A8: Inverter Control Station**

**Appendix III: Summary of VSC HVDC Projects (Worldwide)**

Name	Converter Station 1	Converter Station 2	Cable (km)	Voltage (kV)	Power (MW)	Year
Hellsjön-Grängesberg	Sweden - Hellsjoen	Sweden - Graengesberg	10, Overhead line	180	3	1997
Terranora interconnector (Direktlink)	Australia - Mullumbimby	Australia - Bungalora	59	80	180	2000
Eagle Pass, Texas B2B	USA - Eagle Pass, TX	USA - Eagle Pass, TX		15.9	36	2000
Tjæreborg	Denmark - Tjæreborg/Enge	Denmark - Tjæreborg/Substation	4.3	9	7	2000
Cross Sound Cable	USA - New Haven, CT	USA - Shoreham, Long Island	40	150	330	2002
Murraylink	Australia - Red Cliffs	Australia - Berri	177	±150	220	2002
HVDC Troll	Norway - Kollsnes	Norway - Offshore platform	70	60	80	2004
Estlink	Estonia - Harku	Finland - Espoo	105	150	350	2006
NordE.ON 1	Germany - Diele	Germany - Borkum 2 platform	203	150	400	2009
HVDC Valhall	Norway - Lista	Norway - Valhall, Offshore platform	292	150	78	2009
Trans Bay Cable	USA - East Bay - Oakland, CA	USA - San Francisco, CA	88	200	400	2010
Caprivi Link	Namibia - Gerus	Namibia - Zambezi	970	500	300	2010
HVDC DolWin I	Germany - Dörpen	Germany - DolWin Alpha platform	165	320	800	2013
HVDC HelWin I	Germany - Büttel	Germany - HelWin Alpha platform	130	N/A	N/A	2013
SydVästlänken	Sweden-Hallsberg Norway-Oslo	Sweden - Hurva	N/A	400	1200	2015
HVDC NordBalt	Sweden - Nybro	Lithuania - Klapeida	450	300	700	2015
Tres Amigas SuperStation	USA - Clovis, New Mexico	USA - Clovis, New Mexico	N/A	N/A	5000	N/A