

THE KIKUYU DETERMINER PHRASE

BY

NJAGI JANE WAMBUI

A dissertation submitted in partial fulfilment for the degree of Masters of Arts in the University of Nairobi

UNIVERSITY OF NAIROBI LIBRARY



0146740 6

AUGUST, 1997

FOR USE IN THE LIBRARY ONLY

DECLARATION

This dissertation is my original work and has not been presented for a degree in any other University.



NJAGI JANE WAMBUI

This dissertation has been submitted for examination with our approval as University supervisors

Mrs. Kiranga J

Mr. Oloo

Dr. B.G.V Nyombe

DEDICATION

TO THE TWO MEN IN MY LIFE

NGANGA NJAU

and

NJAU NGANGA

ACKNOWLEDGEMENTS

I would like to first express my sincere gratitude to my supervisors, Dr. Nyombe, Mr. Oloo and Mrs. Kiranga for their helpful suggestions and guidance as I did this work.

Secondly, I wish to thank Dr. Marete, Mr. Mweri and Mr. Wasike for the time they spared at one moment or other to answer a question or two that I put to them as well as for their willingness to read through and comment on the much works I asked them to. I appreciate also Mr. Mungania's contribution for letting me use his books.

Special thanks go to my husband and son for the support, understanding and appreciation that I got from them. Their contribution to this work is immense.

I greatly appreciate the contributions of the members of my family and particularly my parents Mr. and Mrs. Njagi. The concern and moral support that I constantly got from them provided a driving force to the undertaking of my work. To my brothers and sisters who were always there when I needed them, I am very grateful.

It would be unfortunate if I failed to acknowledge the contribution of my classmate, Peter Mbugua with whom I shared the linguistics class. I would also like to thank my friends Ann, Tom, Omosh, Lex and Nyamberi who were in the Kiswahili linguistics class.

All these people do not at all share any blame for any imperfection that might be spotted in the work.

ABSTRACT

This dissertation analyses the kikuyu Determiner phrase within the principles and parameters theory of Chomsky and Lasnik (1991)

Chapter one is a general introduction to the study that shows among other things an introduction to the language of study, the statement of the problem, the objectives, hypotheses, the theoretical framework and the methodology.

In chapter two we examine the kikuyu nouns. These are looked at in relation to the noun classes that they belong to and the prefixes that determine class assignment. In addition, examples of members of each of the classes are provided.

Chapter three examines the kikuyu determiners. In this chapter each type of the three types of determiners is provided as well as its sub-types. In addition, examples of the determiners occurring with nouns are also provided.

Chapter four forms the major part of the study. In this chapter we examine the proposals that led to the introduction of the determiner phrase (DP) as well as its proposed structure and the effect on the structure of the sentence. We also examine the kikuyu DP and provide a structure for it.

Chapter five provide the summary and conclusions of what was established in chapter four.

KEY TO SYMBOLS AND ABBREVIATIONS

S.....	SENTENCE
NP.....	NOUN PHRASE
VP.....	VERB PHRASE
AP.....	ADJECTIVAL PHRASE
PP.....	PREPOSITIONAL PHRASE
N.....	NOUN
V.....	VERB
A.....	ADJECTIVE
P.....	PREPOSITION
INFL.....	INFLECTION
IP.....	INFLECTIONAL PHRASE
COMP.....	COMPLEMENTIZER
T.....	TRACE
AGR.....	AGREEMENT
AUX.....	AUXILIARY
O.....	MOVE ALPHA
Ø.....	AGREEMENT FEATURES
#.....	NUMBER
#P.....	NUMBER PHRASE
PREF.....	PREFIX

DECLARATION	ii
DEDICATION	iii
ACKNOWLEDGEMENT	iv
ABSTRACT	v
KEY TO SYMBOLS AND ABBREVIATIONS	vi

CHAPTER ONE

1.1 THE LANGUAGE.....	9
1.2 PROBLEM STATEMENT	10
1.3 OBJECTIVES.	12
1.4 HYPOTHESES	13
1.5 RATIONALE FOR THE STUDY	13
1.6 THE SCOPE AND LIMITATIONS OF THE STUDY	13
1.7 THEORETICAL FRAMEWORK	15
1.7.1 THE X-BAR THEORY	17
1.7.2. CASE THEORY	19
1.7.3 GOVERNMENT THEORY	20
1.8 LITERATURE REVIEW	25
1.9 METHODOLOGY	29

CHAPTER TWO

2.1 INTRODUCTION	30
2.2. CLASSES 1 & 2 NOUNS (MU- A-)	30
2.3 CLASSES 3 & 4 NOUNS (MU- MI-)	33
2.3.1 MEMBERS OF CLASSES 3 & 4	34
2.4 CLASSES 5 & 6 (I/RI - MA-)	36
2.4.1. MEMBERS OF CLASSES 5 & 6	36
2.5 CLASSES 7 & 8 (KI- I/CI-)	37
2.1. MEMBERS OF CLASSES 7 & 8	38
2.6 ~CLASSES 9 & 10 (N-)	40
2.6.1. MEMBERS OF CLASSES 9 AND 10	42
2.7 CLASSES 11 & 10 (RU - M-)	43
2.8 CLASSES 12 & 13 (KA - TU-)	44
2.9 CLASSES 14 & 6 (U - MA -)	49

2.10	CLASSES 15 & 6 (KU - MA-)	47
2.11	CLASSES 16 & 15 (HA - KU-)	48

CHAPTER THREE

3.0	INTRODUCTION	49
3.1.1	CARDINAL NUMBERS	49
3.1.2	ORDINAL NUMBERS.	58
3.1.3	INDEFINITE QUANTIFIERS.	60
3.2	DEMONSTRATIVES.	62
3.3	POSSESSIVES	66
3.4	ORDER OF CO-OCCURRENCE.	69

CHAPTER FOUR

4.0	OVERVIEW	72
4.1	THE KIKUYU NOUN PHRASE.	72
4.2	THE STRUCTURE OF THE NOUN PHRASE.	74
4.3	THE DETERMINER PHRASE (DP) ANALYSIS.	75
4.4.	THE STRUCTURE OF DP.	79
4.5	THE KIKUYU 'DP'.	81
4.6	THE POSSESSIVE PHRASE	87
4.7	THE REPRESENTATION OF NUMBER.	90
4.8	NUMBER PHRASE.	92
4.9	EVIDENCE FOR NOUN RAISING	93

CHAPTER FIVE

5.1	SUMMARY	94
5.2.	CONCLUSION.	96
	BIBLIOGRAPHY	97

CHAPTER ONE

1.1 THE LANGUAGE

The present study is based on Kikuyu language. Kikuyu is a loose cover term for the language spoken in the Kikuyu highlands between the upper Tana river and the slopes of mt Kenya, the South western limit being the Nairobi area. This area occupies the central region of the Republic of Kenya.

The correct name for the people and their language is "Gikuyu". The form Kikuyu was adopted by the early European arrivals in the British East Africa from the Swahili (inhabitant of the coast).

Mutahi (1987) in his study of the classification of the dialects of southern mount Kenya proposed seven dialects for Kikuyu: ki-mbeere, ki-Gichugu, ki-ndia, ki-mathira, Northern and Southern dialects. These dialects, as Mutahi found out are spoken in specific areas, so that ki-ndia is spoken in Ndia division, ki-Gichugu in Gichugi division, both of which are found in Kirinyaga district. Kiambu and ki-mbeere are spoken in Embu district while ki-mathira is spoken in some parts of Nyeri district. The Northern dialect is spoken in the other part of Nyeri district and in Murang'a district. Lastly, the southern dialect is spoken in Kiambu district.

Guthrie (1948) in his classification of Bantu languages classified Kikuyu as belonging to class 50E. In this class he recognised the difference between Kikuyu and Ki-embu and does not consider them dialects of the same language.

Since we do not know why Mutahi chose to refer to his seven dialects as dialects of Kikuyu and not dialects of say ki-mbeere, ki-ndia, ki-embu and so on, nor why Guthrie classified Kikuyu and ki-embu separately, we shall only state that our data will be got from the Kikuyu spoken in Mwea division of Kirinyaga district.

This dialect has been chosen primarily because it is the one that I speak.

1.2 PROBLEM STATEMENT.

Abney (1987) argued that a Determiner phrase (DP) is required in order to capture certain similarities between sentences and noun phrases. In our study, we will aim at attesting this claim by Abney by studying the Kikuyu Determiner phrase. In Kikuyu the following forms are found.

1. (a) **Ci-ana Ci-akwa.**
pref - children Agr - mine.
"my children"
- (b) **tw - ana tw - akwa.**
pref - children (young) Agr - mine
"my young children"
2. (a) **ri - ru ri - mwe**
pref - banana (ripe) Agr - one
"One ripe banana"
- (b) **me - ru me - ri**
pref - bananas (ripe) Agr - two
"two ripe bananas"
3. (a) **i - rio i - ria**
pref - food Agr - that
"That food"
- (b) **tu - irio tu - ria**
pref - food (little) Agr - that
"That little food"

4. (a) **A - ndu a - ingi**
pref - people Agr. many
 "Many people"
- (b) **mi - ti mi - ingi**
pref - trees Agr - many
 "Many trees"
5. (a) **Ng'ombe ya Njeri**
cow of Njeri
 "Njeri's cow"
- (b) **Ng'ombe cia Njeri**
cows of Njeri
 "Njeri's cows"

Notice that in Kikuyu like in other Bantu languages, there exists overt agreement between the noun and its modifiers i.e Determiners.

In the sentence AGR is usually assumed to occupy an inflectional position outside the maximal projection of V, as in ,

6.

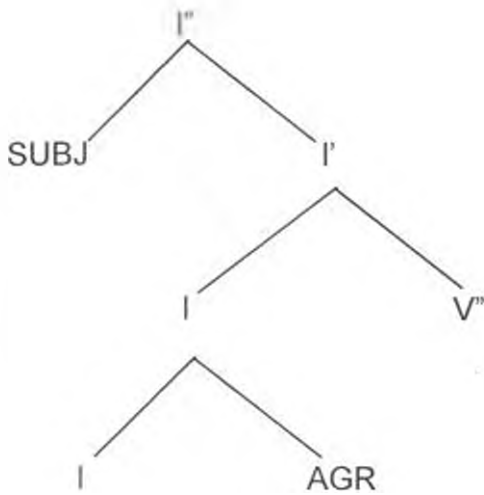

In the examples 1-5, overt agreement in those noun phrases is obvious. If that were true, it is also true that the noun phrase also contains an Agr element just like the sentence.

That being the case, our study will do the following;

- (a) Find out if the Kikuyu noun phrase is headed by an inflectional element, the noun phrase equivalent of sentential INFL which hosts AGR.
- (b) Since the lexical elements of the category INFL in the sentence is the class of modals, the question is then, what is the noun phrase equivalent of modals?

1.3 OBJECTIVES.

In our analysis of the Kikuyu Determiner phrase, we shall aim at meeting the following objectives:

- (a) To find out if the Kikuyu noun phrase is headed by an inflectional element, the noun phrase equivalent of INFL.
- (b) Verify if the surface word order of a Kikuyu determiner phrase is also the base word order.
- (c) Determine what lexical elements occupy the noun phrase inflectional node.
- (d) Determine the structure of the Kikuyu determiner phrase.

1.4 HYPOTHESES.

- (a) That the Kikuyu noun phrase is headed by an inflectional element, the noun phrase equivalent of the INFL found in the sentence.
- (b) That the Noun initial word order within DP in Kikuyu is derived by an (obligatory) movement that moves the noun from an internal position next to its complement to the initial position.
- (c) That determiners occupy the inflectional node in a Kikuyu determiner phrase.

1.5 RATIONALE FOR THE STUDY

The significance of this study is embodied in the fact that to the best of our knowledge this is the first study of its kind. Though a lot of research has been carried out on Kikuyu morphology, phonology and phonetics, very little has been done on its syntax and nothing at all on the determiner phrase. It is thus our hope that this study will fill the obviously existing gap.

Apart from gap filling, this study will also be a contribution in the understanding of the structure of Kikuyu as well as that of other Bantu languages. In addition, it will also be valuable to the current debates across theories concerned with the treatment of issues central to syntax.

1.6 THE SCOPE AND LIMITATIONS OF THE STUDY

The study investigates solely the Kikuyu determiner phrase. Although the study is syntactic, we shall enter into some aspects of morphology since Kikuyu like other Bantu languages is highly agglutinative and a morphosyntactic approach is thus unavoidable.

According to Chomsky (1991), the position of determiner is filled by determiners, possessive elements or pronouns. As such we shall in our study look at the following determiners:-

- (i) Demonstratives.

7. (a) - ya (this)
 (b) - cio (those)
 (c) - ria (that)
 (d) - ci (these)

(ii) Possessives.

- (a) - akwa (mine)
 (b) - ao (theirs)
 (c) - aku (yours)
 (d) - itu (ours)

(iii) Quantifiers.

(i) cardinal numbers

9. (a) - mwe 'one'
 (b) - iri 'two'
 (c) - tatu 'three'

(ii) Ordinal numbers

10. (a) Mbeere - 1st
 (b) Keeri - 2nd
 (c) gatatu - 3rd
 (d) kana - 4th

(iii) Indefinite quantifiers.

11. (a) - othe
 "all"
 (b) - mwe
 "Some"
 (c) ingi
 "Many"
 (d) - nini
 "few"

1.7 THEORETICAL FRAMEWORK.

The study of generative grammar has been guided by several fundamental problems, each with a traditional flavour. The basic concern is to determine and characterize the linguistic capacities of particular individuals. The concern is thus on the states of the language faculty, which is understood to be some array of cognitive trait and capacities, a particular component of the human mind/brain. The language faculty has an initial state, genetically determined: In the normal course of development it passes through a series of states in early childhood, reaching a relatively stable state that undergoes little subsequent change apart from the lexicon. To a good first approximation, the initial state appears to be uniform for the species. The theory of the state attained is referred to as its *grammar* and the theory of the initial state *universal grammar* (UG). On UG, Chomsky (1981:7) has the following to say:

universal grammar may be thought of as some system of principles common to the species and available to each individual prior to experience.

Although certain grammatical principles and rules are universal there are also a lot of variations between different languages. Therefore, UG contains the following:

- (a) A set of absolute universals, notions and principles which do not vary from one language to the next.
- (b) Language specific properties which are not fully determined by UG but which vary cross - linguistically. For these properties a range of choice is offered by U.G.

As a result, Chomsky's (1982) Government and Binding theory made a distinction between the *core* of a language and its *periphery*. The core consists of what we assume to be pure instantiations of UG and the periphery consists of marked exceptions (such as irregular verbs). Note that the periphery will also exhibit properties of UG though less transparently.

The core grammar according to Chomsky comprises of the following:

- (a) lexicon
- (b) syntax
 - (i) categorial component
 - (ii) Transformational component.
- (c) phonetic form
- (d) logical form.

The first two (a & b) comprise the generative procedure of language. The first (a) generates the form of structural descriptions (SD_s) and the second (b) (also called the computational system) characterizes the lexical items that appear in the SD_s . One aspect of an SD is that it has a system of representation called "D- structure" at which lexical items are inserted. The D- structure relates the computational system and the lexicon and expresses lexical properties in a form accessible to the computational system. The SD provides information about properties of each linguistic expression, including its sound and its meaning. The levels of representation PF and LF specify aspects of sound and meaning respectively. One crucial question that arise is how these levels interact. An assumption developed in the *Extended standard theory* (EST), is that these levels are not related directly: rather their relations are mediated by an intermediate level of S-structure: which must relate these three levels in the manner specified in UG.

The periphery of language consists of a system of principles which fall under interacting Sub-systems, each of which comprises a principle or a set of principle which may be subject to parametric variation. These principles are subsumed under the following modules:

- (a) x - bar - theory.
- (b) Bounding theory.
- (c) Binding theory.
- (d) Theta theory.

- (e) Case theory
- (f) government theory.
- (g) control theory.

In the following section we shall give a general survey to the three modules (x-bar theory, case theory, government theory) which relate to our study.

1.7.1 THE X-BAR THEORY

The x-bar theory which forms our tool for structural description was formulated by Chomsky (1980) to describe the properties of all phrases in the grammars of different languages. The theory is a general descriptive account of phrase-structures in the base-component.

The X-bar syntax stipulates that, for all lexical categories: Nouns, verbs, prepositions and Adjectives, the format of phrasal projection can be represented by means of a layered representation such as the one below:

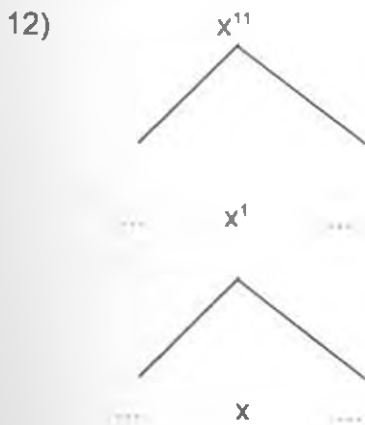

Where x stands for N, V, A or P.

According to the x-bar theory, all phrases are headed by a lexical 'head' upon which the other constituents in a question are dependent. In the terminology of traditional linguistics we say that all phrases are *endocentric*. This is reiterated

in the principle referred by stockwell (1981) as the *endocentric* Requirement which specifies that:

.....each phrasal expansion consists of a head of the same feature specification.

The lexical head of a projection may also be called a *zero projection* (X^0) as opposed to single bar projection (x^1), double bar projection (x^2) and so on.

The theory distinguishes two levels of projections.

- (a) Complements combine with x (or lexical head) to form x^1 projections. For example, a head noun combines with its complement to form N^1 .
- (b) The specifiers combine with x^1 to form the maximal projection x^{11} . As such N^1 combines with the specifier to form N^{11} .

That general format for phrase structure can be summarised in the following PS rules:

X^{11} ——— spec; X^1

X^1 ——— x ; YP.

The x-bar theory thus provides us with a general schema of phrase structure to be used in our study: This may appear as in:

13)

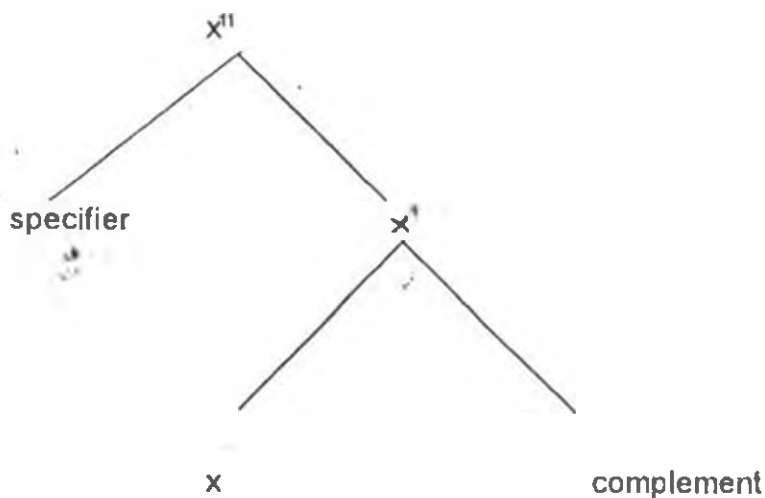

While it is assumed that the above layered schema is universal, the order of constituents with respect to the head of the projection is not universally fixed. It is therefore possible that other principles of grammar account for the various constituent orders.

1.7.2. CASE THEORY

Case theory is the module of grammar concerned with the distribution of NP^s. The case filter of the theory imposes a requirement on the licensing of NP:

Case filter

Every overt NP must be assigned abstract case.

This principle was proposed by Chomsky (1982) as,

- NP, where NP has no case.

As a result, any sentence that may contain a lexical NP that is not assigned any case is ungrammatical.

Case is assigned to NPs in particular syntactic environments. In most cases, a particular terminal element of the environment can be identified as the determinant of case assignment, for example, the direct object of a verb can be said to "get its case from" the verb and similarly for the object of a preposition. Since nominative case is assigned to subjects of tensed clauses, the tense morpheme has been identified as the assigner of nominative case.

Case assignment can take place only when the case - assigner and the NP to which it assigns case bear a structural relation to one another known as *government*. In addition to that, case is only assigned by case assigners which include the following: verbs, prepositions, tense, AGR and possessive markers. The categories Nouns and adjectives do not assign case. So are the non-transitive verbs and the transitive verbs affixed with the past participle derivation.

If case is assigned under government, and if every lexical NP must be case marked, then every lexical NP must appear in a position in which it is governed by one case assigner. Thus, in general a lexical NP cannot appear as the subject of a non-tensed clause.

We distinguish abstract case from morphological case and distinguish two types of abstract case: structural case (nominative and accusative) and inherent case (the English genitive). While structural case is subject to the requirement that the case assigner govern the NP which it case-marks, an inherent case - assigner must govern and theta-mark the NP which it case-marks.

The fundamental properties of case assignment in English have been given by Chomsky (1982) as follows:

- (i) NP is nominative if governed by AGR.
- (ii) NP is objective if governed by V with subcategorization feature:- NP (i.e transitive).
- (iii) NP is oblique if governed by P.
- (iv) NP is genitive in [NP-X]
- (v) NP is inherently case marked as determined by properties of its [-N] governor.

The case assigned in (i)-(iv) is structural and the one assigned in (v) is inherent.

1.7.3 GOVERNMENT THEORY

The concept of government refers to particular syntactic relationships between governors and the elements that they govern. It could also be said to refer to the relation between the head and its complements. With the exception of the INFL whose AGR governs its subject, all other lexical heads govern their complements. The relation of government is defined by Rizzi (1986:291) as.

X governs Y if Y is contained in the maximal projection of X^{max}, and X^{max} is the smallest maximal projection containing Y, and X C- commands Y

Governors include:

- (i) X (V, N, P, A)
- (ii) {INFL [+tns] AGR} = INFL
- (iii) NP; where Y (the governee) - NP_i.

Within the theory, a governor cannot govern anything outside its maximal projection. The domain of a governor is therefore only those elements that it C-commands and which are not protected by a barrier. Barriers to government include: S, NP, Adj, PP and VP.

Another assumption apart from that of core and periphery of language that we need to note is a distinction between *inflectional* and *derivational* processes of morphology, the latter internal to the lexicon, the former involving computational operations of a broader syntactic scope. These computational operations might involve *word-formation* or *Checking*. Consider for example the past tense form *walked*. The lexicon contains the root {walk} and the inflectional feature [tense], one value of which is [past] among other properties. One of the computational rules, call it \mathcal{R} associate the two by combining them. One way of interpreting this descriptive comment is that {walk} is drawn from the lexicon as such, then \mathcal{R} combines it with [past]. Another way is that processes internal to the lexicon (redundancy rules) form the word *walked* with the properties {walk} and [past] already specified. The rule R then combines the amalgam with [past] checking and licensing its intrinsic feature [past].

The earliest version of UG assumed that it provided a format for rule systems and an evaluation metric that assigned a "value" to each generative procedure of the proper format. The crucial empirical condition on UG then, was that the system provided only a few high valued I-languages consistent with the kind of data available to the child.

This approach to UG recorded many achievements, but faced one fundamental and recurrent problem; the tension between descriptive and explanatory adequacy. On explanatory adequacy Radford (1981:16) says; that;

A grammar attains explanatory adequacy just in case it correctly predicts which sentences are and are not well formed in the language, correctly describes their structure, and also does so in terms of a highly restricted set of optionally simple universal, maximally general principles which represent psychologically plausible natural principles of mental computation and are learnable by the child in a limited period of time, and given access to limited data.

On descriptive adequacy he says:

A grammar is descriptively adequate if it correctly predicts which sentences are (and are not) syntactically, semantically and phonologically well - formed in the language and also correctly describes the syntactic, semantic and phonological structure of the sentences in the language in such away as to provide a principled account of the native speakers intuition about this structure.

This tension between the above two was recognised as stemming from the kind of rule systems that were being considered. The most plausible solution was to try to "factor out" overarching principles that govern rule application generally, assigning them to UG; the actual rules of grammar could then be given in the simplest form, with these principles ensuring that they will operate in such a way as to yield the observed phenomena in their full complexity. The limit that might be reached is that rules are eliminated entirely, the 'apparent rules' being deduced from general principles of UG, in the sense that the interaction of the principles would yield the phenomena that the rules had been constructed to describe. To the extent that this result could be achieved, the rules postulated for particular languages would then be shown to be epiphenomena.

The pursue of such ideas led to the introduction of the principles and parameters approach. The hypothesis of the approach being that all principles are assigned to UG and that language variation is restricted to certain options as to how the principles apply. If so, then rule systems are eliminable at least for the core language, consider,

giku, gikombe giakwa t ?

Where cup of mine

"Where is my cup?"

The goal is to show that the question word moves from the position of *t* by a general principle that allows movement quite freely, with the options, interpretations, and varying status determined by the interaction of this principle with others.

The principles and parameters approach aims to reduce descriptive statements to two categories:

- (a) language invariant
- (b) language particular.

The language invariant statements are principles (including the parameters, each on a par with a principal of UG), while the particular ones are specifications of particular values of parameters. The notion of construction, in the traditional sense, effectively disappears. Thus there are no such constructions as verb phrase, or interrogative and relative clause or passive and raising constructions. Rather, there are just general principles that interact to form these descriptive artifacts.

The parametrical options available in the approach are restricted to two cases:

(a) *properties of the lexicon.*

In this case we have the options as to how non-substantive (functional) elements (determiners) are realized and variations in global properties of heads (do verbs precede or follow their complements?).

(b) *The point of derivation from D-structure to LF at which structures are mapped to PF (S-structure).* In this category we find, for example languages with overt movement of question phrases and languages without. Similarly, we find languages with overt manifestation of grammatical case and others with virtually no such manifestation, such as Kikuyu.

The general expectation, for all constructions, is that languages will be very similar at the D-structure and LF levels, since it is unlikely that there are parameters that affect the form of LF representation or the computational process from S-structure to LF.

The principles that have been investigated fall into two general categories; principles that are applied to construct derivations (transformational operations and conditions on the way they operate): and principles that apply to representations (licensing conditions). The transformational operations are movement (adjunction, substitution), deletion, and perhaps insertion; these may be thought of as instances of the general operation Affect whose operations are constrained by the conditions of locality and others. Licensing conditions at the external interface levels PF and LF establish the relation of language to other faculties of the mind and D-structure condition specify the manner in which lexical properties are expressed in grammatical structures.

The principles have further structure. There are natural groupings into modules of language (Binding theory, Theta theory, case theory). Certain unifying concepts enter into many or all modules: conditions of locality, "geometrical" properties

defined on phrase markers and so on. There are also certain general ideas that appear to have wide applicability, among them, principles of economy stating that there can be no superfluous symbols in representations or superfluous steps in derivations. As these principles are given an explicit formulation, they become empirical hypotheses with specific import and range. The principle of economy of derivation requires that computational operations must be driven by some condition on representations, as a “last resort” to overcome a failure to meet such a condition. Interacting with other principles of UG, such economy principles have wide ranging effects, and may, when matters are properly understood, subsume much of what appears to be the specific character of particular principles. As such, the task that the approach has is to show how the phenomena derived by the rule system can be deduced from the invariant principles of UG with parameters set in one of the permissible ways.

Other traditional problems also assume a different form under a principles and parameters approach. Questions of typology and language change will be expressed in terms of parameter choice while the theory of language acquisition will be concerned with acquisition of lexical items, fixing of parameters, and perhaps maturation of principles.

UG has been said to be a simple and elegant theory with fundamental principles that have an intuitive character and broad generality. By dissolving the notion of construction and moving towards “rule -free” systems, the principles and parameters approach carries this tendency considerably forward.

1.8 LITERATURE REVIEW

The works reviewed in this study are put into three categories.

- (i) Works directly related to our study.
- (ii) Works on syntax in general and on the Kikuyu syntax in particular.
- (iii) Works on the theory.

In the first category, there is no other work that we know of that has been done on the Kikuyu Determiner phrase.

In the second category, Mchombo (1993) has proved most useful since it contains an article by Carstens, V, "*on nominal morphology and DP structure*", in which she examines the Kiswahili Determiner phrase. Carstens proposes that Kiswahili NPs (So - called) are covert Determiner phrases with phonologically empty heads to which the noun raises obligatorily, through the number projection. She further argues that the noun class prefixes are added to nouns as number morphology, by gender - specific redundancy rules. Since the prefixes only mark number, she argues for the creation of a functional head 'number' which selects NP complements. This analysis to her, make possible a uniform treatment of number morphology on the one hand, and independent number words on the other. This information is very important to our study since we are going to make the same proposals for Kikuyu. After all, Kikuyu and Kiswahili are very closely related.

Abney, S (1987), in an unpublished doctoral dissertation on "*The English noun phrase and its sentential aspects*" provides a lot of relevant material. It is in this work that after working on many languages, Abney proposed the creation of a functional category, Determiner, which was to be considered the head of the noun phrase. To our study, this dissertation proved worthwhile because it not only provided us with information on the origin of the Determiner phrase but also information on the argument that he gave to support the proposal. In addition to that, the work also offers a proposed structure of DP which will help us in determining the structure of a Kikuyu DP.

Tang, C.J. (1990) - an article "*A note on the DP analysis of the chinese noun phrase*" proved quite useful. In the article, Tang argues that apart for the creation

of a DP in Chinese, a functional category K (which stands for classifier morpheme) is needed in order to cater for the various aspects of Chinese that she provides. She proposes that unlike the claims by Abney (1987) a D in Chinese takes the maximal projection of the proposed K as its complement, while K itself takes an NP as its complement.

Although Kikuyu and Chinese are different, Tang's proposals help us greatly in our proposal that in Kikuyu unlike in Chinese, we need the creation of a number phrase to be the complement of D and to take the NP as its complement.

Pollock (1989) "*verb movement, universal grammar and the structure of IP*" provides us with the much needed structure of a sentence. This proves quite useful since in our analysis of the Kikuyu DP it will be important to consider the similarities that exist between the sentence and the noun phrase.

For example, in Kikuyu, agreement within the sentence and within the noun phrase is overt. In that case both types of constructions have INFL as their heads but the noun phrase equivalent of INFL is the determiner.

Nyombe B.G.V. (1994), in an unpublished paper on "*the DP analysis of Bari NP*" analysis the structure of the Bari determiner phrase. Although the languages are quite different, the information provided proves important since issues concerning the Determiner phrase are well brought out.

Marete, (1983) unpublished M.A. dissertation on "*Grammatical agreement in Kimeru*" provides material on agreement which is helpful in our examination of the Kikuyu determiner phrase. After all, it is the presence of AGR in the noun phrase that provides evidence for the creation of a DP.

Polome (1969) gives us a lot of information on Kiswahili Determiners. It is in this book that we get information about the order of co-occurrence of the noun and the determiners. Although Kikuyu and Kiswahili are different languages, we

know that they are also closely related and as such the information proved relevant.

Ssewangi (1993) unpublished M.A. dissertation on *The syntax of empty categories in Kiswahili simple sentences*, a GB approach, proved relevant to our study. This is because the theory that he used is related to what we intend to use.

Other dissertations that proved useful are, Thandi (1988), Kaviti (1993), Gatede (1991) and Mukuria (1986).

Works done in or on Kikuyu such as overtone (1973), Mutahi (1977), Barlow (1962) Armstrong (1967), Gechaga (1953) and Gathenji (1981) have provided a lot of ideas on Kikuyu's order of cooccurrence among the determiners and even on the determiners themselves.

In the third category, the basic text for the theory is Chomsky and Lasnik's *principles and parameters Approach* (1991). In this text we find a lot of necessary information on what the theory stipulates and this makes it possible to apply the same to the language of our study.

Chomsky (1982) *Lectures on Government and Binding* provides us with information on Chomsky's idea of UG. The text also provides the subsystems of the theory some of which will prove very important in our study.

Haegeman L (1991) *Introduction to Government and Binding theory* provides us with simplified notes on the Government and Binding theory.

Other relevant works include Riemdijk and Williams (1986), Horrocks (1987) cowper (1988), Radford (1981) and (1988).

1.9 METHODOLOGY

Since I am a native speaker of the dialect used in the study, I relied on my intuitive knowledge of Kikuyu. But, in order to give a comprehensive data, consultations with other Kikuyu speakers was found to be very useful for the purpose of cross-checking.

Because the core of our study is theoretical, a lot of emphasis has been laid on library research.

CHAPTER TWO

THE KIKUYU NOUNS

2.1 INTRODUCTION

As our title suggests the primary interest in this work is the Determiner phrase. But, since kikuyu Determiners are modifiers of the nouns, and they bear prefixes determined by the noun, it is only fair that we briefly examine the kikuyu nouns. As in all other bantu languages, nouns in kikuyu are divided into a number of different classes, each class being marked by a distinctive singular and plural prefix which goes in front of the noun stem.

The nouns are not assigned the classes arbitrarily. All the nouns which occur in any one class are linked together by certain very definite and clearly defined rules of distinction although as Barlow (1960) observed, the meaning of the nominal prefixes are not determinable with a lot of certainty. Even so, a rough survey of the contexts of the nouns groups may yield indications as to the underlying significance of the use of some of the group prefixes.

2.2. CLASSES 1 & 2 NOUNS (MU- A-)

Classes 1 and 2 are the classes into which nouns denoting human beings are placed and there is no word in them which does not denote human beings. The noun prefixes for words in classes 1 and 2 are, mu- in to the singular and a- in the plural. For example

1.a)	mu -ndu	a -ndu
	<i>person</i>	<i>people</i>
b)	mu -tumia	a -tumia
	<i>married woman</i>	<i>married women</i>

- | | | |
|----|------------------|-----------------|
| c) | mu -hiki | a -hiki |
| | <i>bride</i> | <i>brides</i> |
| d) | mu -ciari | a -ciari |
| | <i>parent</i> | <i>parents</i> |
| e) | mu -geni | a -geni |
| | <i>guest</i> | <i>guests</i> |

The singular nominal prefix *mu-* is written as *mw-* when the noun stems begin with vowels *a, e* and *-i* as in

- | | | | |
|-----|----|--------------------|----------------|
| 16) | a) | mw -ene | <i>owner</i> |
| | b) | mw -arimu | <i>teacher</i> |
| | c) | mw -igariki | <i>dancer</i> |

Before *-e* the plural noun prefix *a-* is written as *e-* (since $a + e = e$)

- | | | |
|-----|--------------|---------------|
| 17) | e -ne | <i>owners</i> |
|-----|--------------|---------------|

Most of the nouns found in class 1 are derived from verbs by affixing *mu-* and a final vowel *-i* to the verb root. The consequent noun is usually the name of the person who does the action described by the verb. For example the noun *muturi* "blacksmith" is derived from the verb *gutura* "to make". The plural of the same is formed by the replacement of *mu-* with *a-*.

- | | | | | |
|-----|----|-----------------|-------------------|--------------------|
| 18. | a) | gukia | mu -kii | a -kii |
| | | <i>to grind</i> | <i>grinder</i> | <i>grinders</i> |
| | b) | kuruga | mu -rugi | a -rugi |
| | | <i>to cook</i> | <i>cook</i> | <i>cooks</i> |
| | c) | kugura | mu -guri | a -guri |
| | | <i>to buy</i> | <i>buyer</i> | <i>buyers</i> |
| | d) | guthoma | mu -thomi | a -thomi |
| | | <i>to read</i> | <i>reader</i> | <i>readers</i> |
| | e) | gutura | mu -turi | a -turi |
| | | <i>to make</i> | <i>blacksmith</i> | <i>blacksmiths</i> |

The nouns of class 1 are also formed from adjectives by the addition of the *mu-* prefix to the adjectival stems as in.

- | | | | |
|--------|-------------------------------|---|--|
| 19) a) | -theru
<i>clean</i> | mu -theru
<i>holy person</i> | a -theru
<i>holy people</i> |
| b) | -ega
<i>good</i> | mu -ega
<i>good person</i> | e -ga
<i>good people</i> |
| c) | -nini
<i>small</i> | mu -nini
<i>junior person</i> | a -nini
<i>junior people</i> |
| d) | -kuru
<i>old</i> | mu -kuru
<i>old person</i> | a -kuru
<i>old people</i> |

Another way of forming the nouns of class 1 is the use of the passive form of a verb (with the *-w* extension) as in

- | | | |
|--------|------------------------------------|---|
| 20) a) | gutuma
<i>to send</i> | mu -tumwa
<i>apostle</i> |
| b) | kuroga
<i>to bewitch</i> | mu -rogwo
<i>bewitched person</i> |

As already observed, classes 1 and 2 are human classes since just as Leaky (1959) observed, human beings are considered to have a higher spirit than all the other nouns in the spirit world. The nouns in classes 3/4 are associated with a lower category of spirit and those in classes 9/10 are considered to have a category which is even lower, the members of classes 7/8 being mostly inanimate and lifeless objects. This information could be given in a diagram such as (21)

21)

<u>Classes</u>	<u>Members</u>
First class spirit	1/2 human
Second class spirit	3/4 trees, wood, ground
Third class spirit	9/10 animals, birds
No spirit	7/8 objects

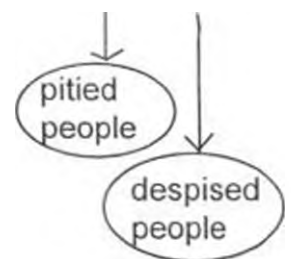

Although all nouns denoting human beings are supposed to belong to classes 1/2, certain human beings are deliberately taken out of them and reduced to the status of some other classes (as shown in the diagram). This was done if a community wanted to show that it pitied or despised such a person. The kikuyu noun **ki-guta** *lazy person* is made to belong to classes 7/8, the classes of inanimate objects because lazy people were not respected in the kikuyu society. The noun **N-gia** *poor person* contrary to **ki-guta** is demoted to classes 9/10 because such a person was pitied in the communal society of the kikuyu people.

2.3.8 CLASSES 3 & 4 NOUNS (*MU- MI-*)

These classes consist of impersonal nouns that take *mu-* as the singular noun prefix and *mi-* as the plural prefix. These nouns are principally those which are regarded as having second class spirits, (i.e. a spirit of a lower category than that of humans, but nevertheless of considerable importance). These may include:

22)	a)	mu-ti	mi-ti
		<i>tree</i>	<i>trees</i>
	b)	mu-gumo	mi-gumo
		<i>fig tree</i>	<i>fig trees</i>
	c)	mu-gambo	mi-gambo
		<i>voice</i>	<i>voices</i>
	d)	mu-rimu	mi-rimu
		<i>disease</i>	<i>diseases</i>

The singular noun prefix *mu* is usually written as *mw* when the noun stem begins with a vowel as in;

23	a)	mw-ere	<i>rat-tail millet</i>
	b)	mw-aka	<i>year</i>

- | | | |
|----|----------------|----------------------|
| c) | mwa-aki | <i>fire</i> |
| d) | mw-eri | <i>moon or month</i> |

2.3.1 Members of classes 3 & 4

1. names of big trees and plants

- | | | | |
|-----|----|---------------------|----------------------|
| 10. | a) | mu-ti | mi-ti |
| | | <i>tree</i> | <i>trees</i> |
| | b) | mu-tarakwa | mi-tarakwa |
| | | <i>cedar tree</i> | <i>cedar trees</i> |
| | c) | mu-tare | mi-tare |
| | | <i>bramble tree</i> | <i>bramble trees</i> |
| | d) | mu-gumo | mi-gumo |
| | | <i>fig tree</i> | <i>fig trees</i> |

However, although a considerable number of trees and plants belong to classes 3/4, a considerable number are removed from this class to class 5, because they are more properly associated with that class as a result of their various properties and other associations with magic or ceremonial significance.

2) The word for body and some names of its parts

- | | | | |
|------|----|-----------------|-----------------|
| 25). | a) | mw-iri | mi-iri |
| | | <i>body</i> | <i>bodies</i> |
| | b) | mu-twe | mi-twe |
| | | <i>head</i> | <i>heads</i> |
| | c) | mu-romo | mi-romo |
| | | <i>lip</i> | <i>lips</i> |
| | d) | mu-gongo | mi-gongo |
| | | <i>back</i> | <i>back</i> |

3 Words connected with the ground

- 26) a) **mu-karo** **mi-karo**
ditch *ditches*
- b) **mw-ena** **mi-ena**
side *sides*
- c) **mu-tindiruko** **mi-tindiruko**
slope *slopes*
- d) **mu-thia** **mi-thia**
end *ends*

4) Many items made from wood or plants

- 27) a) **mu-gwi** **mi-gwi**
arrow *arrows*
- b) **mu-rango** **mi-rango**
door *doors*
- c) **mu-kwanju** **mi-kwanju**
walking stick *walking sticks*
- d) **mw-atu** **mi-atu**
beehive *beehives*

5. Some creatures promoted from animal classes 9/10

- 28) a) **mu-ruthi** **mi-ruthi**
lion *lions*
- b) **mu-riu** **mi-riu**

three horned jackson *three horned jacksons*

Chameleon *Chameleon*

- c) **mu-nyongoro** **mi-nyongoro**
millipede **millipedes**

These creatures have been promoted from the usual animal classes because of various reasons. The lion for example was respected for his courage and just

rule in most kikuyu traditional stories. The millipede was seen to be very wise while the three-horned jacksons chameleon was promoted due to the fact that it was believed to have played a major part in an endeavour to give man eternal life. Contrary, the ordinary chameleon *kiimbu* was hated and feared for it was seen as the one that caused man to be mortal.

2.4 CLASSES 5 & 6 (I/RI - MA-)

The nouns of class 5 take the noun prefix *ri-* or *i-* in the singular, and those of class 6 are plural and take the prefix *ma-*. The noun prefix *ri-* is used when the noun stem starts with a vowel and *i-* if it starts with a consonant.

29)	a)	i-tunda	ma-tunda
		<i>fruit</i>	<i>fruits</i>
	b)	i-rigu	ma-rigu
		<i>banana</i>	<i>bananas</i>
	c)	i-gego	ma-gego
		<i>tooth</i>	<i>teeth</i>
	d)	i-timu	ma-timu
		<i>spear</i>	<i>spears</i>
	e)	ri-twa	ma-ritwa
		<i>name</i>	<i>names</i>

2.4.1. Members of classes 5 & 6

	1)	Names of fruits	
30)	a)	i-babai	ma-babai
		<i>pawpaw</i>	<i>pawpaws</i>
	b)	i-cungwa	ma-cungwa
		<i>orange</i>	<i>oranges</i>
	c)	i-embe	ma-embe
		<i>mango</i>	<i>mangoes</i>
	d)	i-renge	ma-renge

pumpkin *pumpkins*

2) **Objects of ceremonial, religious and magical significance**

- 31) a) **i-higa** **ma-higa**
hearthstone *hearthstones*
- b) **i-timu** **ma-timu**
warrior spear *warrior spears*
- c) **ri-itho** **ma-itho**
eye *eyes*
- d) **i-ithanua** **ma-thanwa**
axe-head *axe-heads*

3) **Names of humans who play a special religious part in family life**

- 32) a) **i-the** **ma-ithe**
father *fathers*
- b) **Nyina (inyina)** **ma-nyina**
mother *mothers*
- c) **Guka (iguka)** **ma-guka**
grandfather *grandfathers*
- d) **cucu (icucu)** **ma-cucu**
grandmother *grandmothers*

2.5 CLASSES 7 & 8 (KI- I/CI-)

The nouns of these classes are principally inanimate objects; a proportion are man-made, others are natural.

The noun prefixes for these classes are *ki-* or *gi-* in the singular and *ci-* or *i-* in the plural.

Singular nouns take the *ki-* prefix if the next consonant in the word is voiced. For example:

- 33) a) **ki-rima** *mountain*
b) **ki-hato** *broom*

c) ki-rimu a fool

The *gi-* prefix is taken by nouns if the next consonant in the word is voiceless, as in;

- 34) a) gi-tanda bed
b) gi-kabu basket
c) gi-canuri comb

If the stem of a word starts with a vowel, then the plural prefix *ci-* is used.

- 35) a) ki-ondo ci-ondo
basket baskets
b) ki-ura ci-ura
frog frogs

But, when a consonant starts a stem, then the *c-* is dropped and the prefix becomes *i-*.

- 36) a) gi-kombe i-kombe
cup cups
b) ki-ratu i-ratu
sandal sandals
c) gi-tonga i-tonga
rich person rich people
d) gi-ti i-ti
stool stools

2.5.1. Members of classes 7 & 8

1) Miscellaneous objects, most of them domestic

- 37) a) gi-ti i-ti
stool stools
b) ki-hato i-hato
broom brooms
c) ki-nya inya
gourd gourds

- d) **ki-ondo** **ci-ondo**
slang bag *slang bags*

2) **Ideas or concepts**

- 38) a) **gi-kuu** **i-kuu**
death *deaths*
- b) **ki-roto** **i-roto**
dream *dreams*
- c) **ki-rumi** **i-rumi**
curse *curses*
- d) **gi-keno** **i-keno**
joy *joys*

3) **Nouns denoting particular places and rooms**

- 39) a) **ki-raaro** *sleeping place*
b) **ki-gomano** *meeting place*
c) **ki-thambiro** *washing (bathing) place*
d) **gi-thinjiro** *slaughter house*

It is worth to note that the above nouns are formed from verbs by affixing the class 7 prefix *ki-* and the suffix *-o*.

4) **Some names of body parts**

- 40) a) **ki-ara** **ci-ara**
finger *fingers*
- b) **ki-ero** **ci-ero**
thigh *thighs*
- c) **ki-cinde** **ci-ande**
shoulder *shoulders*

5) **Words connected with agricultural land and several collective terms**

- 41) a) **ki-rima** **i-rima**
hillside *hillsides*
- b) **gi-thaka** **i-thaka**
an estate *estates*

- c) **ki-mera** **i-mera**
season *seasons*
- d) **ki-ama** **ci-ama**
council (meeting *councils (meetings*
of elders) *of elders)*

6) **People demoted from human classes 1/2**

These people are held in contempt or scorn or hatred. They are spoken of contemptuously and are thought to be inferior or abnormal in the society.

- 42) a) **ki-onje** **ci-onje**
disabled person *disabled people*
- b) **ki-maramari** **i-maramari**
vicious person *vicious people*
- c) **gi-tumumu** **i-tumumu**
blind people *blind people*
- d) **ki-hii** **i-hii**
uncircumcised man *uncircumcised men*

In the traditional kikuyu society, people who had disabilities were thought to have had them because of a curse from the spirits. It was often suspected that the situation was a punishment for a wrong committed by one of the family members. Such people were therefore never looked at sympathetically and especially if they did not belong to one's own family.

For a person to be vicious **ki-maramari** was very wrong because such a person was never going to settle. As a result the person was hated. A **kihii** was not respected since he was associated with bad behaviour and most of all because he could not keep a secret.

7) **Some creatures demoted from classes 9/10**

- 43) a) **ki-ura** **ci-ura**
frog *frogs*

- | | | |
|----|--------------------|-------------------|
| b) | ki-gunyu | i-gunyu |
| | <i>maggot</i> | <i>maggots</i> |
| c) | ki-ng'ang'i | i-ng'ang'i |
| | <i>crocodile</i> | <i>crocodiles</i> |
| d) | ki-imbu | ci-imbu |
| | <i>chameleon</i> | <i>chameleons</i> |

The above animals could have been demoted because they were not liked *king'ang'i* was hated since it is very dangerous and was therefore to be avoided.

Kiimbu "chameleon" was considered untrustworthy because of its ability to change colour and more so because it was accused of having caused man to be mortal. It was therefore regarded with hatred and fear and as a result was demoted to the class of imanimates. The frog **kiura** was demoted because of its pride and conceitedness while the maggot was hated because of its association with decay.

2.6 CLASSES 9 & 10 (N-)

The nouns in these classes take nasal prefixes N- in their singular (class 9) and plural forms. The specific quality of the nasal (N-) is usually determined by the sound which it precedes.

The sound becomes *m-* when it occurs before consonant *-b* and *-p*, as in,

- 44) a) mburi *goat*
 b) mbata *goose*

It takes the form *n-* before consonants *c d g j k t* and *lh*,

- 45) a) njege *porcupine*
 b) njogu *elephant*
 c) ngia *pauper*
 d) ndungata *servant*
 e) nyumba *house*

The form *ny-* is also usually taken by the nasal when it proceeds vowels as in

- 46) a) nyamu *animal*
- b) nyondo *hammer*
- c) nyeki *grass*
- d) nyeni *wild spinach*

In these two classes, the singular and plural prefixes are the same but the tone is usually different.

2.6.1. Members of classes 9 and 10

1) Words for abstraction

- 47) a) nduma *darkness*
- b) ng'aragu *famine*
- c) ngeithi *.greetings*
- d) ngatho *gratitudes*
- e) ndwari *illness*

2) Miscellaneous objects

- 48. a) nyumba *house*
- b) njata *star*
- c) mboco *beans*
- d) ngu *firewood*
- e) nguo *clothes*
- f) nyungu *pot*

3) names referring to people who differ from the norm

- 49) a) ngombo *serf or slave*
- b) ngia *pauper*
- c) njangiri *outcast*
- d) njamba *boaster*

These nouns obviously denote humans and therefore should be in classes 1/2.

But, for language purposes they have been demoted not to the classes of the

despised people 7/8 but to classes 9/10 because they are merely pitied.

4) **Most names of animals and living creature**

- 50) a) ng'ondu *sheep*
 b) ng'ombe *cow*
 c) nyoni *bird*
 d) ndegwa *bull*
 e) ngi *fry*
 f) ngari *leopard*

In these classes are therefore nearly all birds, reptiles, insects and mammals. The only exceptions are those which, for some specific reasons have either been promoted as we have seen or which have been deliberately removed from the correct classes because they are objects of scorn, derision, hatred or fear, or in a few cases because their mode of life brings them automatically into some other class. The diagram below (51) shows this:

51)	<u>Classes</u>	<u>Members numerous</u>	
First class spirit	1/2	Humans	
Second class spirit	3/4	trees, woods, ground liked animals	
			↑ promoted to 3/4
Third class spirit	9/10	animal, birds	
No spirit	7/8	objects	↓ demoted to 7/8 hated animals

5. **Words borrowed from English**

- 52) a) piru *pillow*
 b) caati- *shirt*
 c) thuti *suit*
 d) thenema *cinema*

2.7 **CLASSES 11 & 10 (RU - M-)**

The nouns belonging to these classes are connected by the concept of undulation,

that is, waves and oscillations. They take the noun prefix *ru-* in the singular and *n-* in the plural.

Some members of these classes are,

55)	ru-ii	n-jui
	<i>river</i>	<i>rivers</i>
b)	ru-rimi	n-imi
	<i>tongue</i>	<i>tongues</i>
c)	ru-ua	nj-ua
	<i>dried skin</i>	<i>dried skins</i>
d)	ru-baru	m-baru
	<i>rib</i>	<i>ribs</i>
e)	ru-rigi	nd-igi
	<i>string</i>	<i>strings</i>

2.8 CLASSES 12 & 13 (KA - TU-)

These classes are called diminutive classes since most of the nouns are small objects, people or animals. Any noun in kikuyu can be turned from an ordinary object of its own class into a diminutive by placing it in class 12. The singular noun prefix for diminutive is *ka-* and the plural is *tu-*.

Nouns of this class may be derived from the nouns of other classes by replacing their prefixes with *ka-* (or *ga-*),

54)	a)	gi-kabu	ga-kabu	tu-kabu
		<i>basket</i>	<i>small basket</i>	<i>small baskets</i>
	b)	mi-ngunda	ka-gunda	tu-gunda
		<i>garden</i>	<i>small garden</i>	<i>small gardens</i>
	c)	ihiga	ka-higa	tu-higa
		<i>stone</i>	<i>small stone</i>	<i>small stones</i>
	d)	kirima	ka-rima	tu-rima
		<i>mountain</i>	<i>small mountain</i>	<i>small mountains</i>

e)	gicanuri	ga-canuri	tu-canuri
	<i>comb</i>	<i>small combs</i>	<i>small combs</i>

The original class prefix may at times remain so that in deriving a diminutive the prefix *ka-* is added to an already prefixed noun. For example;

55)	a)	muti	ka-muti	tu-muti
		<i>tress</i>	<i>small tree</i>	<i>small trees</i>
	b)	mundu	ka-mundu	tu-mundu
		<i>person</i>	<i>small person</i>	<i>small persons</i>
	c)	ngui	ka-gui	tu-gui
		<i>dog</i>	<i>small dog</i>	<i>small dogs</i>
	d)	njira	ga-cira	tu-cira
		<i>foot path</i>	<i>narrow foot path</i>	<i>narrow foot paths</i>
	e)	kiratu	ka-ratu	tu-ratu
		<i>shoe</i>	<i>small shoe</i>	<i>small shoes</i>

2.9 CLASSES 14 & 6 (U - MA -)

Class 14 is the class of abstract nouns. The noun prefix for it is *u-* in the singular and *Ma-* in the plural. For example;

56.	a)	u-gwati	<i>danger</i>
	b)	u-tuuro	<i>life</i>
	c)	u-menyo	<i>knowledge</i>
	d)	u-rimu	<i>foolishness</i>
	e)	u-go	<i>magic</i>

When a noun stem begins with a vowel, the singular prefix changes to *w-* as in;

57).	a)	w-endo	<i>love</i>
	b)	w-atho	<i>law</i>
	c)	w-ira	<i>work</i>
	d)	w-ega	<i>importance</i>

Some members of class 14 are not abstract nouns. These include

- 58) a) u-thiu *face*
b) u-ta *bow*
c) u-cunu *gruel*
d) u-riri *bed*

Most members of classes 14 do not have a plural prefix and those few that have take *Ma-* (like class 6)

- 59) u-riri *bed* ma-riri *beds*

There are a number of words contained in the group which do not conform to its type. These words have lost the prefix, the stem being left unaccompanied except by a terminal vowel. For example

- 60) a) cira *legal case*
b) tiri *soil*
c) nyota *thirst*
d) thina *poverty*
e) thahu *ceremonial uncleanliness*

Many of these irregular nouns are words imposed from other languages such as kiswahili

- 61) a) cai *tea*
b) tuba *file*
c) tawa *lamp*

In kikuyu any adjective stem can be turned into an abstract noun. This is done by placing the *u-* prefix in front of the adjective stem to turn it into a noun having the attribute implied by the adjectival. For example

- 62) a) -nene *u-nene*
large *largeness*
b) -eru *w-eru*
white *whiteness*

- | | | |
|----|---------------|-------------------|
| c) | -theru | u-theru |
| | <i>clean</i> | <i>cleaniness</i> |
| d) | -noru | u-noru |
| | <i>fat</i> | <i>fatness</i> |

The affixation of prefix *u-* (or *w-*) and the final vowel *-i* to a verb root also derives abstract nouns from verbs

- | | | | |
|-----|----|---------------------|-----------------------|
| 63) | a) | kuruga | u-rugi |
| | | <i>to cook</i> | <i>art of cooking</i> |
| | b) | gukia | u-kii |
| | | <i>to grind</i> | <i>grinding</i> |
| | c) | gutura | u-turi |
| | | <i>to smith</i> | <i>smithing</i> |
| | d) | kurima | u-rimi |
| | | <i>to cultivate</i> | <i>agriculture</i> |
| | e) | kuroga | u-rogi |
| | | <i>to bewitch</i> | <i>witchcraft</i> |

2.10 CLASSES 15 & 6 (KU - MA-)

The few ordinary nouns that occur in class 15 are only three and they are singulars of dual's, and take prefix *ku-*. They include;

- | | | | |
|-----|----|----------------|------------|
| 64) | a) | ku-guru | <i>leg</i> |
| | b) | gu-oko | <i>arm</i> |
| | c) | gu-tu | <i>ear</i> |

They form their plurals by the addition of the *ma-* prefix just as in class 6.

- | | | | |
|-----|----|----------------|-------------|
| 65) | a) | ma-guru | <i>legs</i> |
| | b) | mo-ko | <i>arms</i> |
| | c) | ma-tu | <i>ears</i> |

In addition to the three ordinary nouns, all the forms of the infinitives of verbs belong to class 15.

The form that the infinitive takes is usually determined by its environment.

KŪ- is used when the infinitive is followed by a voiced consonant;

- 66) a) ku-ruga *to cook*
 b) ku-rira *to cry*

KU- when followed by the vowel *-u* and then a voiced consonant

- 67) a) ku-una *to break*
 b) ku-uga *to say*

KW- when it is followed by a vowel (or two) and then a voiced consonant.

- 68) a) kw-oha *to tie*
 b) kw-uria *to talk*

GU- When it is followed by a voiced consonant; as in

- 69) a) gu-tonga *to get rich*
 b) gu-teng'era *to run*

GW- When followed by a vowel (or two) and then a voiceless consonant

- 70) a) gw-itika *to reply*
 b) gw-itia *to boast*

2.11 CLASSES 16 & 15 (HA - KU-)

There is only one single noun in class 16 in the kikuyu language. The class is locative in concept, the singular prefix being *ha-* and the plural *ku-*. The only noun is:

71. a) **ha-ndu** **ku-ndu**
 b) *place* *places*

PC
1.1.10

CHAPTER THREE

THE KIKUYU DETERMINERS

3.0 INTRODUCTION

As indicated in Chapter Two, Chapter Three is going to act as a springboard in the analysis of Kikuyu Determiner Phrase. Here we shall analyse the Kikuyu determiners which include; quantifiers, possessives, and demonstratives. This is in line with Stockwell (1977:55) who observed that the noun in Bantu may be modified by the three types of determiners that we have named.

3.1 QUANTIFIERS

These are words used with the nominal form to show quantity. Quantifiers in Kikuyu include, Cardinal Numbers, Ordinal Numbers and Indefinite Quantifiers.

3.1.1 Cardinal Numbers

The following cardinal numbers are the basis of the numeral system in Kikuyu (The hyphen indicates those that take agreement)

-mwe

one

-iri

two

-tatu

three

-na

four

-tano

five

-tandatu

six

mugwanja

seven

-nana *nyanja*

eight

kenda

nine

ikumi

ten

For the purpose of counting only, the concord for class 9/10 is used so that we have:-

i-mwe

one

i-giri

two

i-thatu

three

i-nya

four

i-thano

five

i-thathatu

six

i-nyanya

eight

Numerals one to six including eight take prefixes in the noun phrase to agree with the head noun. For example, in the phrases below the numeral *-mwe* "one" takes the prefix *ki-* to agree with the noun *kiondo* "basket" which is in class 7.

73)	a)	kiondo	ki -mwe
		basket	one
		<i>one</i>	<i>basket</i>

In the next phrase the numeral -mwe one appears again but this time with the prefix *u-* to agree with the head noun *uriri* "bed" which is in class 13.

75)	a)	u-riri	u-mwe
		bed	one
		<i>One</i>	<i>Bed</i>

The numeral numbers seven, nine and ten are special in that they do not take any agreement prefixes, for example:-

a)	Miti mugwanja	<i>Seven Trees</i>
	Matumbi mugwanja	<i>Seven Eggs</i>
	Athigari mugwanja	<i>Seven Soldiers</i>
b)	Miti kenda	<i>Nine trees</i>
	Matumbi kenda	<i>Nine Eggs</i>
	Athigari kenda	<i>Nine Soldiers</i>
c)	Miti Ikumi	<i>Ten Trees</i>
	Matumbi ikumi	<i>Ten Eggs</i>
	Athigari ikumi	<i>Ten Soldiers</i>

The numerals Seven, Nine and Ten have been thought to be contractions of verbal clauses linked with pregnancy and birth. The number Seven "Mugwanja" is said to be a contraction of the clause:

75)	Mweri	wa	mugwa	nja
	Month	of	fall	outside
	<i>The month</i>	<i>of</i>	<i>falling</i>	<i>outside</i>

The reason for this clause is given by Leakey (1959:20) as being:

The kikuyu believe and not without good reason that the seventh month of human pregnancy is the most crucial one. It is during this month that a miscarriage can be most dangerous to the mother; a premature baby born during the seventh month is very rarely able to survive under Kikuyu condition. It is this fear of the seventh month of pregnancy that gives rise to the verbal clause.

The number 9 is associated with the last month of pregnancy. The word *Kenda* is likely to be a contraction of the clause;

76)	Kaana	kari	nda
	child	be	womb
	<i>The child is in the womb</i>		

The number ten is associated with the child coming out of the womb after the nine months of pregnancy are over. The word *ikumi* comes from the verb **kuuma** 'to come out'

The table below specifies the prefix with which a numeral will take with each of the noun classes.

Class Number	Noun prefix	1	2	3	4	5	6	8
1.	mu-	u	-	-	-	-	-	-
2.	a-	-	e	a-	a-	a-	a-	a-
3.	mu-	u	-	-	-	-	-	-
4.	mi-	-	i-	i-	i-	i-	i-	i-
5.	ri/i-	ri-	-	-	-	-	-	-
6.	ma-	-	-me-	ma-	ma-	ma-	ma-ma-	-
7.	ki/gi-	ki-	-	-	-	-	-	-
8.	i-	-	i-	i-	i-	i-	i-	i-
9.	n-	i-	-	-	-	-	-	-
10.	n-	-	i-	i-	i-	i-	i-	i-
11.	ru-	ru-	-	-	-	-	-	-
10.	n-	-	i-	i-	i-	i-	i-	i-
12.	ka/ga-	ka-	-	-	-	-	-	-
13.	tu-	-	twi-	tu-	tu-	tu-	tu-	tu-
14.	u-	u-	-	-	-	-	-	-
6.	ma-	-	me-	ma-	ma-	ma-	ma-	ma-
15.	ku-	ku-	-	-	-	-	-	-
6.	ma-	-	me-	ma-	ma-	ma-	ma-	ma-
16.	ha-	ha-	-	-	-	-	-	-
15	ku-	ku-	kw-	gu-	ku-	gu-	gu-	ku-

Table 1. Noun classes and numeral prefixes

The stems for the numerals four and eight are slightly different when modifying class 10 nouns. Instead of **-na** *four* and **-nana** *eight*, the nasal becomes palatalised giving **inya** and **inyanya** respectively. For example in;

- 77)
- | | | | |
|----|-------------------------------|----|-----------------------|
| a) | Nyoni inya | b) | nyumba inya |
| | Birds four | | Houses four |
| | <i>Four birds</i> | | <i>Four houses</i> |
| c) | Nyoni inyanya | d) | nyumba inyanya |
| | Birds eight | | Houses eight |
| | <i>Eight birds</i> | | <i>Eight houses</i> |

The numbers above ten are expressed as ten and one, ten and two and so on and an agreement prefix is required only on the part of the numerals 11 to 16 and 18, as shown below:

- 75)
- | | |
|----|-----------------------|
| a) | ikumi na -mwe |
| | ten and one |
| | <i>eleven</i> |
| b) | ikumi na -iri |
| | ten and two |
| | <i>twelve</i> |
| c) | ikumi na -tatu |
| | ten and three |
| | <i>thirteen</i> |
| d) | ikumi na -na |
| | ten and four |
| | <i>fourteen</i> |
| e) | ikumi na -tano |
| | ten and five |
| | <i>fifteen</i> |

- f) **ikumi na -tandatu**
ten and six
sixteen
- g) **ikumi na mugwanja**
ten and seven
seventeen
- h) **ikumi na -nana**
ten and eight
eighteen
- i) **ikumi na kenda**
ten and nine
nineteen

For example

79. a) **Tuhii ikumi na kamwe**
boys ten and one
eleven boys
- b) **Tuhii ikumi na twiri**
boys ten and two
twelve boys
- c) **tuhii ikumi na tutatu**
boys ten and three
thirteen

d) **tuhii ikumi na tuna**

boys ten and four

fourteen boys

To express numbers twenty and above, the word mirongo *units* is used to stand for tens. Twenty is two tens; **mirongo iiri**. For example;

80) a) **Tuhii mirongo iiri**

boy units two

twenty boys

Thirty is three tens

81) a) **Matunda mirongo itatu**

fruits units three

Thirty fruits

The numerals between twenty and thirty are formed as follows.

- 82) 20. Mirongo iiri
21. Mirongo iiri na -mwe
22. Mirongo iiri na -iri
23. Mirongo iiri na -tatu
24. Mirongo iiri na -na
25. Mirongo iiri na -tano
26. Mirongo iiri na -tandatu
27. Mirongo iiri na mugwanja
28. Mirongo iiri na -nana
29. Mirongo iiri na kenda

The numbers thirty to ninety are as below:

- 30. Mirongo itatu
- 40. Mirongo ina
- 50. Mirongo itano
- 60. Mirongo itandatu
- 70. Mirongo mugwanja
- 80. Mirongo inana
- 90. Mirongo kenda

The word for a hundred is **igana**. It is a class 5 word which takes the class 6 plural form **magana**

- 83) a) **iti** **igana**
 chairs hundred
 A Hundred chairs
- b) **iti** **magana** **meri**
 chairs hundred two
 Two hundred chairs
- c) **iti** **magana** **matano** **ma** **mirongo itatu**
 chairs hundreds five of unit three
 Five hundred and thirty chairs

The word for thousand is the class 9/10 noun **ngiri**

- 84) a) **Miti** **ngiri** **imwe**
 trees thousand one
 One thousand trees

- b) **Miti** **ngiri** **ithatu** **na** **magana** **mugwanja**
 Trees thousand three and hundred seven
One thousand and seven hundred trees

The word million is **mirioni**. It belongs to classes 9/10 where most borrowed words belong. For instance;

- 85) a) **Aciari Mirioni** (i-mwe)
 parents million one
One Million Parents

Multiples of millions are expressed by following the word **mirioni** by a numeral agreeing with class 10.

- 86) a) **andu** **mirioni** **igiri**
 persons million two
 two *million* *people*
- b) **miti** **mirioni** **ithano**
 trees million five
 Five *million* *trees*

3.1.2 Ordinal Numbers.

These are numbers that denote order. In kikuyu, an ordinal number is expressed by the cardinal numeral concorded with the noun group to which the thing numbered belongs. It follows its noun and is joined to it by **-a** (of) which takes the appropriate pronominal prefix. In the case of "first" the word *mbeere*, "first/front" is used rather than **-mwe one**. For example,

- 87) a) **Nyumba** **ya** **mbeere**
 house of first
 The *first* *house.*

The ordinal numbers in Kikuyu are:

1st	Mbeere
2nd	Keeri
3rd	Gatatu
4th	Kana
5th	Gatano
6th	Gatandatu
7th	Mugwanja
8th	Kanana
9th	Kenda
10th	Ikumi

The ordinal numbers 7, 9 and 10 remain unchanged.

Below are examples of ordinal numbers occurring with nouns;

88. a) **Mundu** **wa** **gatatu**
 person of third
 The third *person*

- b) **Mundu** **wa** **mugwanja**
 person of seven
 The seventh *person*

- c) **Mundu** **wa** **kenda**
 person of nine
 The ninth *person*

3.1.3 Indefinite quantifiers.

These are words that are used to indicate the unquantified specimens. In kikuyu, indefinite quantifiers include the following:

-othe	"all" or "the whole"
-mwe	"some"
-nini	"few"
-ingi	"many or more"

3.1.3.1.-othe

This indefinite quantifier takes pronominal prefixes to agree with the modified noun. For example:

89) a) **Nyumba y-othe**
House all
The whole house

b) **waganu w-othe**
Naughtiness all.
All Naughtiness

c) **ciringici-othe**
shillingall
all the shillings

3.1.3.2. -mwe

Like -othe this one also takes pronominal prefixes, as in (90)

90) a) **Tuhii tu-mwe**
boys some
Some of the boys

b) **Mabuku ma-mwe**

books some

Some of the books

In addition to the above, this quantifier may be used substantially in Kikuyu;

91) a) **E na mamwe**

He has some

b) **Me na imwe**

They have some

3.1.3.3. -nini

This quantifier also fully agrees with the noun that it modifies, For example in:

92) a) **Tu-irio tu-nini**

food little

Little food

b) **ka-ria ka-nini**

milk (little) little

little milk

3.1.2.4 -ingi

"much" (singular form); "many" (plural form)

This quantifier, like all the others that we have seen agrees with the noun it modifies and so co-occurs with a noun determined prefix. For example:

93) a) **mu-tu mu-ingi**

flour a lot

alot of flour

- b) **Mi-ti** **mi-ingi** **muno**
 Trees many very
 Very many trees

Like the quantifier **-mwe**, this one could also be used substantially; as in;

- 94) a) **Ndoneire** **nyingi**
 He did not give me many
 did not give me many (much).

- b) **Makinya** **maingi**
 footprints many
 Many footprints

3.2 DEMONSTRATIVES.

Every language has its different ways of marking the relation between the speaker and hearer in regard to proximity using demonstrative. Kikuyu distinguishes the following proximities for demonstrative purposes:

- a) Reference to what is near to the speaker
- b) Reference to what is near the hearer
- c) Reference to what is far away from both speaker and hearer
- d) Reference to a past event, thing, and so on.

The demonstrative that show reference to what is near to the speaker corresponds to "this" and "these" in English and is used to refer to people or things close at hand to the speaker; in near proximity. For example:

- 95) a) **Muti** **uyu**
 tree this
 this tree

b) **Itunda** **riri**
fruit this
This fruit

c) **Mugate** **uyu**
bread this
This bread

d) **gitanda** **giki**
bed this
This bed

A second type of demonstrative is used to refer to people or things which are a short distance away from both speaker and hearer, that is several metres away. For example:

96) a) **Muti** **uria**
tree that
that tree

b) **Miti** **iria**
trees those
Those trees

c) **Matunda** **maria**
fruits those
Those fruits

- d) **Mugate** **uria**
 Bread that
That bread

The third type of demonstrative used refers to people or things which are a long distance away from both speaker and hearer. This demonstrative is formed from the demonstrative immediately above by lengthening the initial vowel and a change of tone. For example:

- 97) a) **Muti** **uuria**
 tree that
That tree (far away)

- b) **Matunda** **maaria**
 Fruits those
Those fruits (far away)

- c) **Mugate** **uuria**
 bread that
That bread (far away)

Lastly, kikuyu has another type of demonstrative used to refer to people or things which are near to the hearer but further away from the speaker. These include:

- 98) a) **Muti** **ucio**
 tree that
That tree (near you)

- b) **Matunda** **macio**
 fruits those
Those fruits (near you)

- c) **Migate** **iyo**
bread those
that bread (near you)

In discourse this demonstrative is used to refer back to someone or something which has already been mentioned in the preceding sentence. For example, in the following extract from a kikuyu story about a hyena "*hiti imwe*", "**One hyena**" is introduced in sentence (a). In sentence (b) when the hyena is referred to again, the demonstrative **iyo**, *that* is used.

- 99) a) **Tene tene muno nikwari na hiti imwe**
Long, long ago there was one hyena
- b) **Hiti iyo niyari ngoroku muno**
That hyena was very greedy.

The table below lists four types of demonstratives for each of the nouns classes

Class	noun	this/these	that/those	that/those	that/there
1.	mu-	uyu	uria	uuria	ucio
2.	a-	aya	aria	aaria	ucio
3.	mu-	uyu	uria	uuria	ucio
4.	mi-	ino	iria	iiria	iyo
5.	ri/i-	riri	riria	riiria	riu
6.	ma-	maya	maria	maaria	macio
7.	ki/gi-	giki	kiria	kiiria	kiu
8.	i-	ici	iria	iiria	icio
9.	n-	ino	iria	iiria	iyo
10.	n-	ici	iria	iiria	icio
11.	ru-	ruru	ruria	ruuria	ruu
10.	n-	ici-	iria	iiria	icio
12.	ka/ga -	gaka	karia	kaaria	kau
13.	tu-	tutu	turia	tuuria	tuu
14.	u-	uyu	uria	uuria	ucio
6.	ma-	maya	maria	maaria	macio
15.	ku-	guku	kuria	kuuria	kuu
6.	ma-	maya	maria	maaria	macio
16.	ha-	haha	haria	haaria	hau
15.	ku-	guku	kuria	kuuria	kuu

Table 2. Noun classes and demonstratives

3.3 POSSESSIVES

Possessives indicate ownership of persons or items. In Kikuyu, there are six forms of possessives each of which is made up of the following three elements:

- The pronominal class concord
- The connective particle -a

-The relevant possessive stem.

The six possessive stems for first, second and third persons are listed in the table below:

100.

	Singular	Plural
1.	-akwa (<i>my</i>)	-itu (<i>our</i>)
2.	-aku (<i>your</i>)	-anyu (<i>yours</i>)
3.	-ake (<i>his/her</i>)	-ao (<i>their</i>)

Below are some examples of possessives with a class 10 word (*mburi*) and a class 7 word (*gikabu*)

101) a) **Mburi** **ciakwa**
Goats mine
my *goats*

b) **Mburi** **ciaku**
Goats yours
your *goats*

c) **Mburi** **ciake**
goats his/her
His/Her *goats*

102) a) **Gikabu** **giakwa**
Basket Mine
My *basket*

b) **Gikabu** **giaku**

	Basket	yours(sing)
	<i>Your</i>	<i>basket</i>
c)	Gikabu	Kiao
	Basket	theirs
	<i>Their</i>	<i>basket</i>
d)	Gikabu	kianyu
	Basket	Yours (plural)
	<i>Your</i>	<i>basket</i>

The table below lists the prefix which these possessive items take with each of the noun classes. An example is given for each.

Noun Class	Noun prefix	possessive	Example
1.	mu-	w-	mwarimu wao
2.	a	a-	aarimu akwa
3.	mu	w-	muti wakwa
4.	mi-	y-	miti yake
5.	i-	ri-	itumbi riakwa
6.	ma-	ma-	matumbi mao
7.	ki/gi	gi/ki	gikabu giake
8.	i-	ci-	ikabu ciake
9.	n	y-	nyumba yao
10.	n	ci	nyumba ciao
11.	ru	ru	rugongo ruao
10.	n	ci-	ng'ongo ciao
12.	ka/ga	ga-	kamundu gakwa
13.	tu	tw-	tumundu twakwa
14.	u-	a-	uriri wakwa
6.	ma-	ma	mariri makwa
15.	ku-	aw-	kuguru gwake
6.	ma-	ma-	maguru makwa
16.	ha-	ha-	handu hao
15.	ku-	kw-	kundu kwao

Table 3. Noun classes and possessive pronoun prefixes

From what we have seen of kikuyu quantifiers, demonstratives and possessives, we know that these must agree with the modified noun. This agreement is shown on the determiner by the prefixation of that noun's prefix on the determiner or by the concordial form of the class to which that noun belongs.

Thus, in order for a quantifier, demonstrative or possessive to correctly modify a noun it must co-occur with a noun determined prefix. As such it would be okay to claim that Kikuyu quantifiers, demonstrative and possessives constitute **prefix + stem**

Since we have only looked at instances when a noun occurs with either type of the determiners, we wish to find out if all types of determiners can modify one noun and the order in which they do that.

3.4 ORDER OF CO-OCCURRENCE.

Kikuyu, like other Bantu languages has as the unmarked order for determiners to come after the nouns. But, at times, the demonstrative indicating proximity and non-proximity may precede it. This occurs in direct style when the noun determined by the demonstrative is precisely the subject of the conversation.

For example;

103) a) **ucio mundu uria**
 that man the
 That is the man

 b) **Uyu mundu uria**
 this man the
 This is the man

In the above, **mundu** is the subject of the conversation.

Although kikuyu does not have specific definite and indefinite quantifiers, it is important to note that definiteness in Kikuyu may be marked by a demonstrative appearing after the noun but accompanied by a change of tone. For example;

- 104) a) **Mundu** **uria**
 Person the
 The *person*
- b) **Nyumba** **iria**
 Houses the
 The *houses*
- c) **Andu** **aria**
 people the
 The *people*

The relative order of determiners as Polome (1967:143) observed depends upon the closeness of their semantic association with the noun to which they apply. For example, in:

32. a) **Nguo** **ciakwa** **igiri**
 Dresses mine two
 My *two* *dresses*

The possessive **ciakwa** is most closely associated with the noun and therefore follows it immediately.

However, in some cases, another determiner may be more closely related with the noun and may therefore follow it immediately, as in:

- 105) a) **Nguo** **ici** **ciakwa**

Clothes these mine

These clothes of mine

Where it is pointed out that these clothes....not others....are mine.

When following the noun, the demonstrative may appear after the possessive.

For example:

106) a) **Matunda** **makwa** **maria meri**

Fruits mine those two

Those two fruits of mine

But again if the quantifier is more closely related to the noun it precedes the demonstrative.

Obviously performance limitations will restrict the number of determiners that could possibly co-occur with the noun. What is significant is the fact that the order of the noun and determiners in Kikuyu is that of post modification.

In that case, then it is plausible to assume that there is a parameter that accounts for the order of elements within the phrases in Kikuyu. This could be referred to as the "Determiner Parameter", with parametric values as Determiner initial (Pre-modifier position) and Determiner Final (Post-Modifier Position). Kikuyu, it appears, selects the value, determine final.

CHAPTER FOUR

DETERMINER PHRASE ANALYSIS

4.0 OVERVIEW

The paramount aim of this chapter is to find out if the Kikuyu languages' noun phrase is headed by an inflectional element AGR which was found to head those of English, Italian, French and other languages by Abney (1987).

In an attempt to provide the structure of the Kikuyu Determiner phrase, we will propose that the noun initial word order in the Kikuyu noun phrase is derived by the movement of the noun from its base position next to its complement to the initial position.

4.1 The Kikuyu noun phrase.

Unlike the verb, the Kikuyu noun inflects for number and gender. As we saw in chapter three, the noun also exhibits widespread morphological agreement with the determiners that modify it. For example,

107. (a) **Nyumba yakwa**

house mine

my house

(b) **Nyumba ciakwa**

houses mine

my houses

(c) **Nyumba ya Njeri**

house of Njeri

Njeri's house

(d) **Nyumba cia Njeri**

houses of Njeri

Njeri's houses

108). (a) **Muti uyu**

tree this

this tree

(b) **Miti iria**

trees those

those trees

(c) **iria riri**

milk this

this milk

(d) **Maria maya**

milks these

these milks

109) (a) **maembe meri**

mangoes two

two mangoes

(b) **iembe rimwe**

mango one

one mango

(c) **maembe maingi**

mangoes many

many mangoes

(d) **maembe manini**

mangoes few

few mangoes

In (107a-d), (108a-d) and (109a-d), demonstrative pronouns, quantifiers and possessives agree in number and gender with the head noun. In our study, gender refers to forms of attributes by which nouns in some languages of the world are distinguished as belonging to certain semantic, or morphological classes each expressed by specific affixes that can refer only to a particular set of nouns.

However, in (107c-d), we ought to note that there is agreement in number and gender between the head - noun and the thing possessed and not contrary to expectations, with the possessor. Thus, the possessive markers **ya** and **cia** in (107c-d) agree with the possessed **Nyumba** and not the possessor **Njeri**. This was also observed by Austen (1974:46) when he noted that;

It is the gender of the 'possessed' noun rather than that of the 'possessor' that is copied on to the -A- link.

4.2 The structure of the noun phrase.

The examples in (107 - 109), provide us with an easy way to represent the structure of the Kikuyu NP. consider

110.

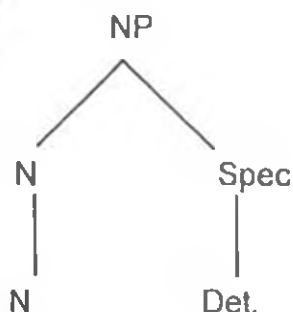

Recall that the order of constituents with respect to the head of a projection is not universally fixed. As such for the time being, let us assume that, that is the structure of a Kikuyu noun phrase until later.

4.3 The determiner phrase (DP) analysis.

Abney (1987) after working on such diverse languages as Turkish, Hungarian and English proposed that there is an AGR occupying a functional head position in the noun phrase. By analogy to clauses, Abney assumed that the NP would also contain an INFL position which in that case would be filled by the determiner. He therefore adopted the position that the noun phrase is in fact a Determiner phrase (DP) where 'D' (determiner) is a nominal Functional element, the noun phrase equivalent of the clausal INFL.

Functional elements according to Chomsky (1991) have feature structure but do not enter into O marking. Their presence or absence is determined by the principle of UG with some parametrization. Each functional element has certain selectional properties; it will take certain kind of complements and may or may not take a specifier. The specifiers typically (though not always) are targets for movement. Hence, functional categories have no independent semantic roles at all.

Abney (1987:266) went on and provided evidence for the Det -as - head analysis. One piece of evidence he provided was that, when determiners stand alone, they continue to behave precisely like noun phrases, which is unexpected unless the phrase they project is in fact a "noun phrase". In addition he argues that pronouns are in fact "intransitive" determiners. However as he put it;

The most convincing reason for adopting the Det - as - head analysis is that the standard analysis simply does not provide enough distinct positions to accommodate the range of elements which appear before the noun phrase (*note that in our case it is after the noun phrase*).

Abney thus proposed the creation of another SPEC position within the noun phrase, one for the possessor (and the external argument) and one for the measure phrase (and the quantifier phrase).

111.

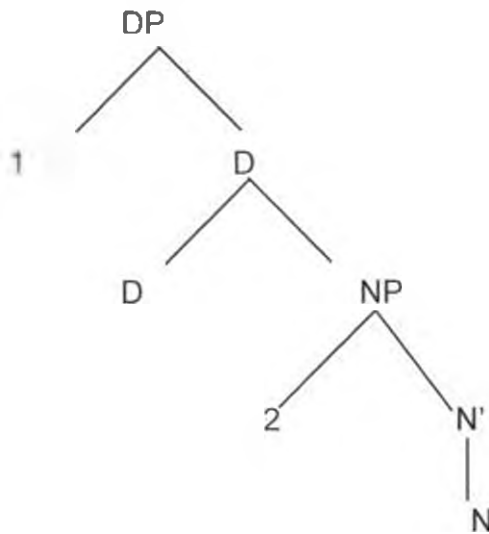

One more piece of evidence for the Det - as - head analysis, and one which is the most important in our work is that there are a large number of languages in which an overt agreement element appears in the noun phrase. For example, in Hungarian, the following is found;

112. (a) **az en kalap- om**
 the 1:Nom hat- 1sg
my hat

(b) **a te kalap - od**
 the you:Nom hat - 2sg
your hat

- (c) a peter kalap - ja
 the peter:Nom 'hat' - 3sg
Peter's hat

Kalap - in the above paradigm is a simple noun, not a verbal form and so would be replaced by any other noun at all. As Abney observed, '**kalap**' agrees with the possessor, marking its person and number with an agreement marker (AGR). The possessor, in turn, bears nominative case, as does the subject of the sentence. It is generally assumed in the Government and Binding theory that nominative case in the sentence is assigned under government by (AGR) hence the co-occurrence of agreement and nominative case. The minimal assumption that we can make of the Hungarian noun phrase is that nominative case is also assigned under government by AGR. As in the sentence, the subject of the noun phrase (such as, the possessor) and AGR are mutually dependent. A nominative possessor can only appear when AGR is present and AGR only when there is a possessor.

Let us assume that Abrey is correct and look at the following Kikuyu examples'

113. (a) **Matumbi makwa.**
 eggs mine
my eggs
- (b) **Itumbi riaku**
 egg yours
your egg

(c) **Itumbi ria Njeri**
egg of Njeri
Njeri's egg

(d) **Matumbi ma Njeri**
eggs of Njeri
Njeri's eggs

114. (a) **Itumbi rimwe**
egg one
one egg

(b) **Matumbi matatu**
eggs three
three egg

(c) **Matumbi maria**
eggs those
those eggs

(d) **Itumbi riria**
egg that
that egg

In the above, - **tumbi** egg is a simple noun. Like in Hungarian, the agreement between the noun and the modifiers which occur with it is obvious. The noun agrees with the determiners, marking its person and number with an agreement marker AGR. The noun in turn bears nominative case which as we already found out is assigned under government by AGR.

In short, what we are saying is that, like Hungarian, Kikuyu also possesses an AGR position in the noun phrase, a position which was found to be occupied by 'D' which is the head of "DP".

4.4. The structure of DP.

According to the X-bar syntax, every category must have a lexical instantiation. In the sentence, modal is the class of Independent (non-affixal) words of category I and complementizer is of category C. If a parallel between the noun phrase and the sentence is to be found, the class of independent words of category D as proposed by Abney is the class of Determiners. The choice of this designation was based on the hypothesis that, since determiners have the properties of functional elements like complementizers and modals they should receive parallel syntactic treatment. Determiners are a closed - class elements. They lack "descriptive content" (They do not provide predicates over individuals but are predicates over predicates; at any rate, they are quantificational rather than predicational). They are often stressless and in many languages such as French and Hebrew, they are clitics and they are affixes in Norwegian.

Pollock (1987) assumed that in the sentence, AGR occupies an inflectional position outside the maximal syntactic projection of V. The obvious hypothesis concerning AGR in the noun phrase is that it occupies a similar inflectional position; as a result, the structures of noun phrase and those of sentences are parallel:

Sentence Structure:

(115). (a)

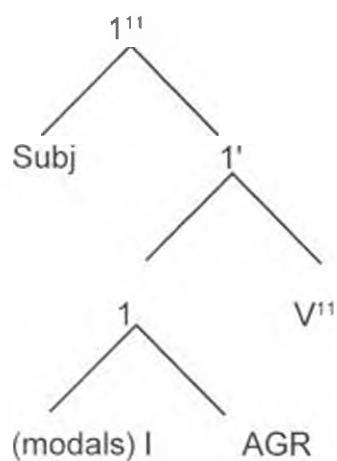

Noun phrase structure

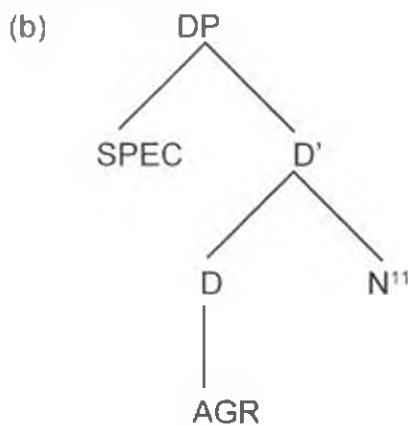

Under such an approach, like the modals and AGR contained in the INFL of a clause such as (115a), determiners and AGR are also found in the D of the noun phrase such as (115b). In (116) below, for example, the D has a lexical instantiation as 'the' in (a) and an abstract instantiation AGR in (b).

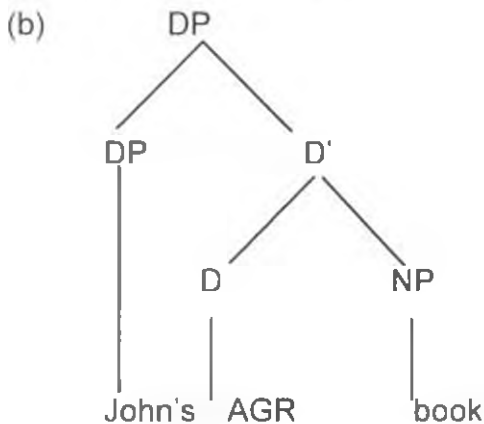
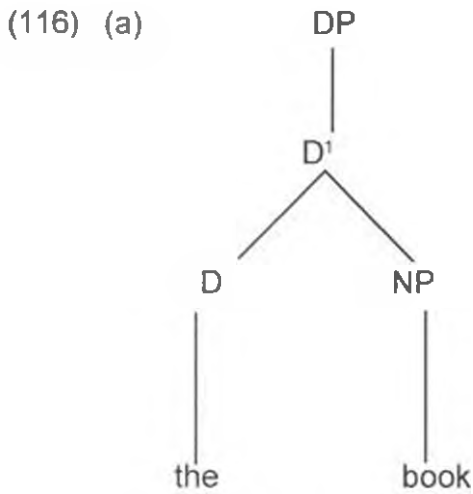

This claim about the parallel relationship between DP-NP at the noun phrase level and IP-VP at the sentence level was summarised by Chomsky et al (1991:33) when they observed that:

..... noun phrases in the informal sense are thus similar in internal structure to clauses (possibly even containing a 'complementizer' position). We might expect then, to find N raising to D, analogous to V - raising to I.

4.5 The kikuyu 'DP'.

Let us agree with Abney that D is a collection of features where stands for AGR features (person, number and gender) which may or may not be lexically realized. Let us also agree with him that Determiners occupy the D node. In

that case, the Kikuyu examples below will have the following structures.

(117) (a) **Nyumba ino**
house this
this house

(b) **Nyumba icio**
house those
those houses

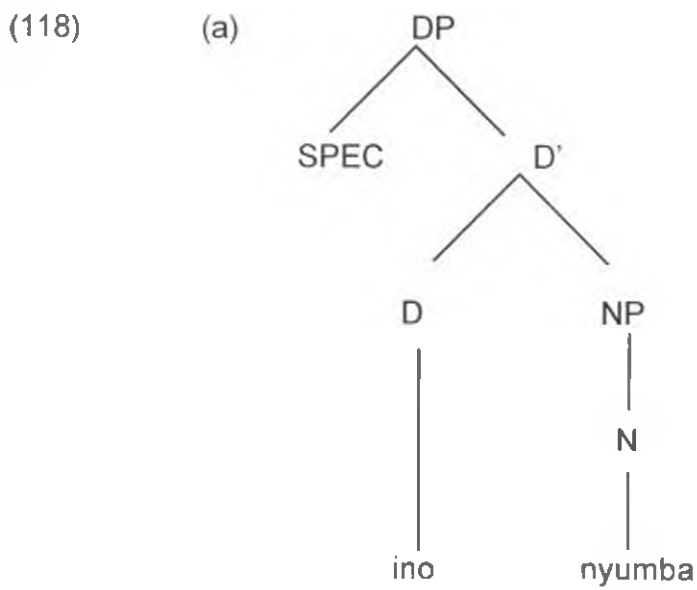

(b)

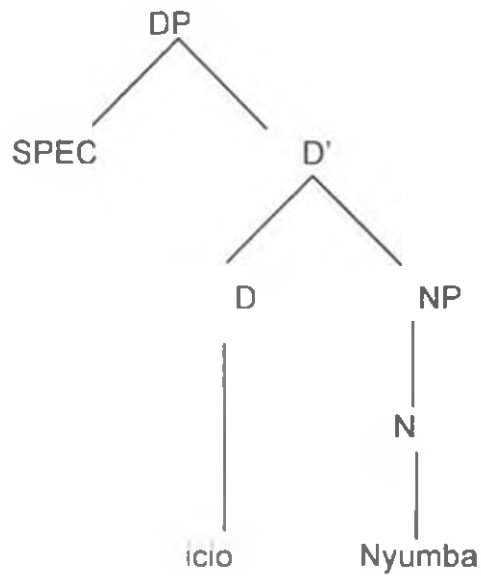

In (118a-b) the head D takes NP complements, and there is obvious agreement between the two. But, note ought to be taken that the Demonstratives **ino** and **icio** appear before the noun **Nyumba** and this is contrary to the structures in (117a-b).

One way of looking at this is to consider the structures in (118a-b) as being underlying. That is to say underlyingly, nouns appear to the right of determiners but to the left of the same at the surface level. What we would thus be claiming is that the noun raises to the initial position for some reason. (Recall the principle of economy of derivation).

In line with Abney, we observed that the noun phrase AGR in Kikuyu would be contained in D. If the agreement features (features) are contained above the noun as shown in (118), it is therefore necessary that the noun raises so that these agreement features are checked. As we saw in 1.8, the syntactic rule R allows the movement for \emptyset feature checking. As a result, the structures in (118) will be replaced by

(119)

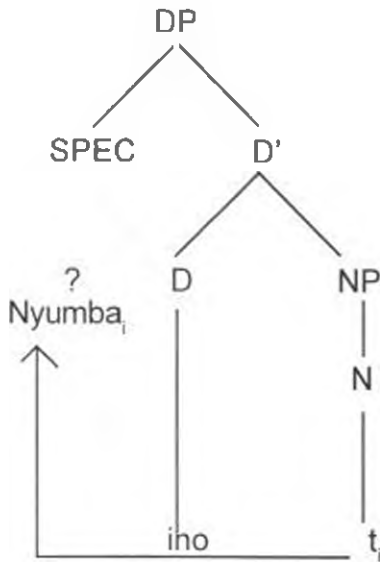

In which, the noun **Nyumba** has moved from the N node position to some other position before the Determiner. The only available position for the landing of the noun is the SPEC-DP position. But, as an X^0 , the noun may raise only to an X^0 position. Since we do not have another X^0 available position, the option that we have is to suppose that the noun moves into an adjoined head position, as is consistent with Chomsky (1991:25).

120.

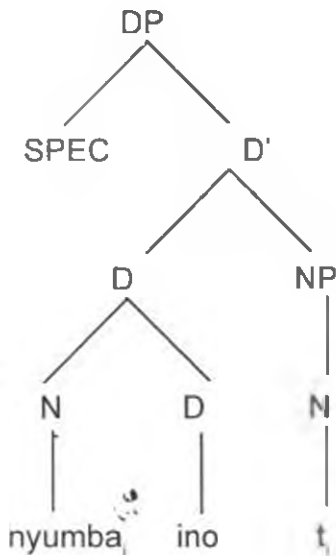

If the above structure (120) were to be considered the structure of a Kikuyu DP, the implication would be that, Determiners occupy the D node in Kikuyu just as they do in Hungarian. In that case, the forms in (121), would have the structures

in (122).

121. (a) **Nyumba yakwa**

house mine

my house

(b) **Nyumba igiri**

house two

two houses

(c) **Nyumba nyingi**

house many

Many houses

(d) **Nyumba iria**

house those

those houses

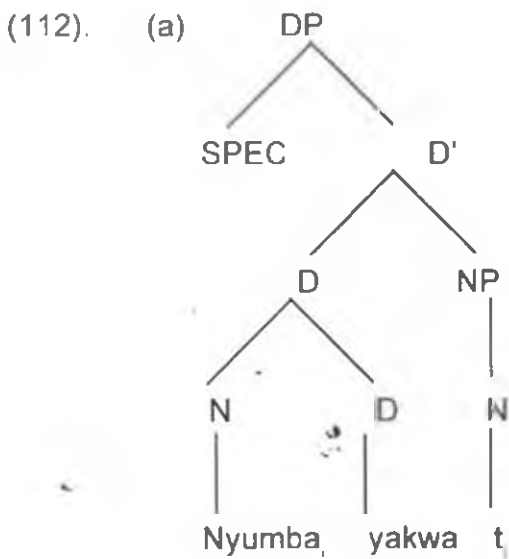

(b)

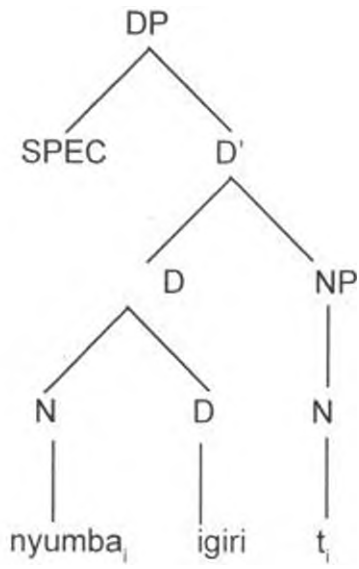

(c)

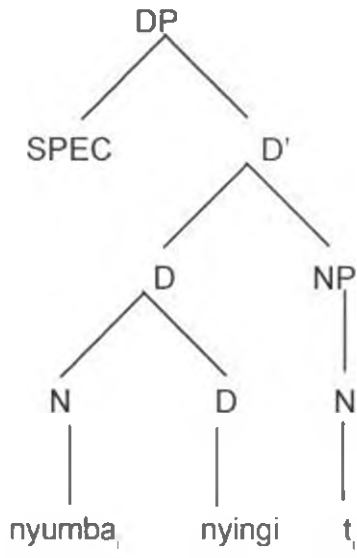

(d)

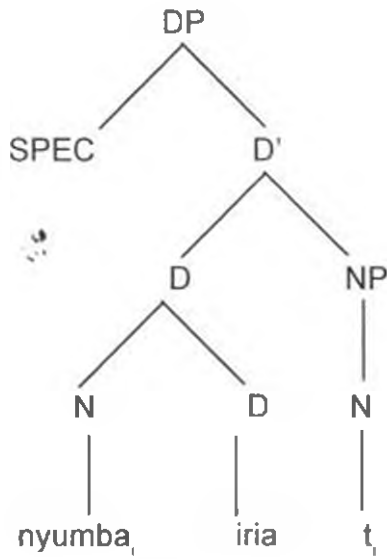

Simply, we are saying that demonstratives, possessives and quantifiers occupy the D position in kikuyu.

4.6 The possessive phrase

In this section, we are going to consider noun phrases with a possessive phrase in Kikuyu.

(123) (a) **Itumbi riakwa**
egg mine
my egg

(b) **matumbi manyu**
eggs yours
your eggs

(c) **Itumbiria Njeri**
egg of Njeri
Njeri's egg

(d) **Matumbi ma Njeri**
eggs of Njeri
Njeri's eggs

From the above, we note that the possessive case of nouns is formed by the use of *-a* (of) as in *ri-a* and *m-a* (in c-d), before the noun denoting the possessor (i.e. *Njeri*). The name of the thing possessed (i.e. *Itumbi*) stands before the particle *-a* and the possessor noun. The particle *-a*, is then given a pronominal prefix such as *ri-* and *m-* (in c-d) to agree with the preceding construct.

Fukui (1986) proposed that possessive markers such as *ria* and *ma* in (123c-d) are contained under the D node. Since the possessed noun, *-tumbi* is the head noun and *Njeri* the specifier, we would expect the examples to have structures like the one below.

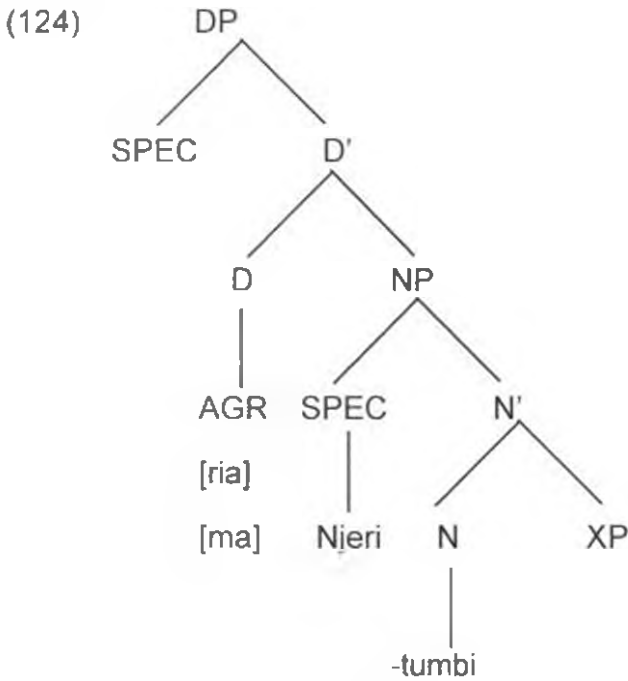

We have already noted that it is the possessed noun (*-tumbi*) that agree's with the possessive markers. As such, it is the noun- *tumbi* which raises for morphological feature checking. As such, the structure in (124) will be replaced by the one in (125)

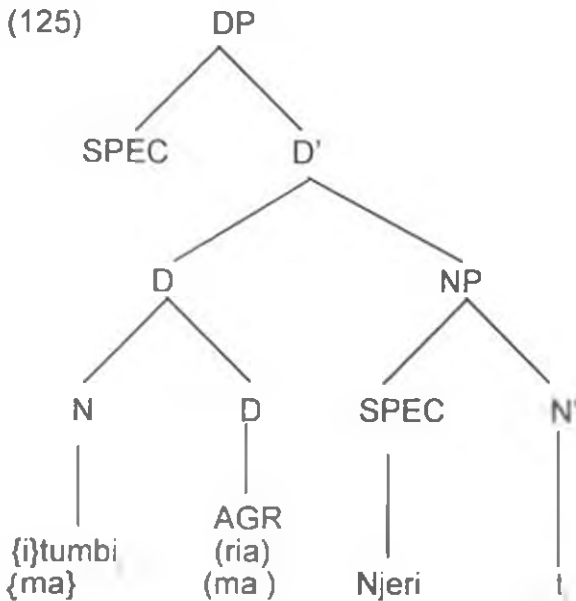

In which, the head noun, *-tumbi*, has moved from its position to be adjoined to D so as to have its morphological features checked, that being a position where features are determined.

The presence of the Agreement markers *i-* or *ma-* on the noun *-tumbi* in the adjoined position could be accounted for by arguing that, as the noun *-tumbi* raises for the morphological feature checking, these features are copied on to it and *-tumbi* therefore changes into either *Ma-tumbi* or *i-tumbi*.

In other words, we are proposing that the gender of the thing possessed, and possibly its case is checked at the adjoined position. If this is true then, it is likely that the case requirements for N in SPEC-NP are somehow satisfied within NP i.e. In-situ.

Although it seems a stipulation that an N' movement to an adjoined D position must take place, this stipulation is not totally arbitrary. Note that Chomsky (1986) proposed that a V is first moved to INFL by V-to-INFL movement to amalgamate with AGR. The V is then moved to C by INFL-to-C movement to derive sentences like (126) with subject auxiliary inversion,

(126) How tall is Jane?

Since a parallel relationship is expected to occur between the sentence and the noun phrase, it is not surprising then to find an N movement to D at the noun-phrase level, by analogy to INFL-to-C movement at the sentence level.

4.7 The representation of number.

In Bantu languages, each noun generally belongs to one of a number of the noun classes. Class membership determines the type of agreement borne by a noun's modifiers and complements (and by auxiliaries and verbs) in relevant syntactic relation with it. The class of a noun as we found out in chapter two typically correlates with a distinctive noun prefix. For example.

(127) (a) mu - whose plural is a - are prefixes of nouns denoting human beings, for example,

(b) **Mu - ndu**

person

(c) **a - ndu**

people

Against arguments by people like Meinhoff that noun prefixes mark both number and gender (class) of the noun, Carstens (1993) argued that, in order to account for the fact that fixed groups of noun stems always bear prefixes associated with particular classes, prefixes should be considered as being specified for number and that the gender specification is supplied entirely by the noun. Thus the choice of each prefix pair is determined by lexical properties of the noun stem. As such, in

(128) **a - ndu**
 people

The prefix *a-* only helps in providing the information that the word is plural but the gender of the same is provided by the stem *- ndu*.

While most languages are like Kikuyu in exhibiting number morphology, in others, grammatical number is indicated by the presence of independent words. Dryer (1989) demonstrated the existence of singular, plural, dual and trial number words. The following Yapese data, an Austronesian language with plural/singular/dual distinction demonstrates this:

(129) (a) **ea rea kaaroo neey**
 sing car this
 this car

(b) **ea gal kaaroo neey**
 dual car this
 These two cars

(c) **l'agruw ea kaaroo (two - dual)**
 two car
 two cars

(d) **ea pi kaaroo neey**
 plural car this
 these cars

It is obvious that Kikuyu and Yapese exhibit number differently. In an attempt to come up with an approach on the basis of maximal generality for the two different

ways of number exhibition, Carstens proposed the creation of a "number phrase".

4.8 Number phrase.

To Carstens (1993), the analysis of number as a syntactic category would provide a unified account for both number words and number morphology. As a result, the proposal that number is always a functional head which select NP complements, was made.

Since we already agreed with Abney (1987) that determiners head functional projections and select NP complements, is it possible then, that both determiner and number phrases select NP complements?

As if to answer the question above, Carstens assumed the projection of number to be the complement of the determiner, as is consistent with this observation, and with the relative ordering of determiners and nouns bearing number morphology in familiar languages. The representation of the noun phrase and its surrounding functional projections is thus as in (130). ((#) = Number).

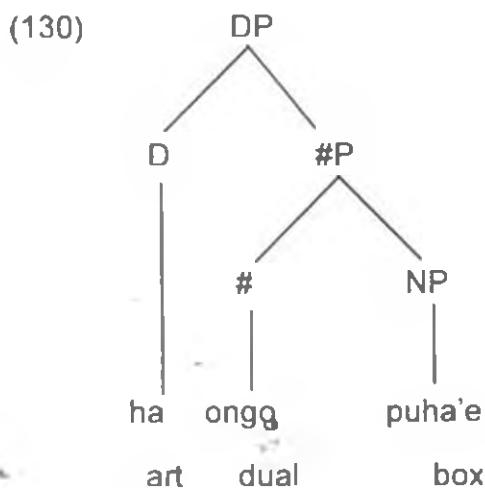

The two boxes

Let us agree with Carstens that (130) is the structure of the noun phrase together with its functional projections. In that case, our argument would be, that, the noun in Kikuyu moves to the initial position so as to be adjoined with number.

4.9 Evidence for noun raising

Let us assume that the surface position of the noun were also its base position and look at the following example.

- (131) **Ng'ombe ino njega**
 cow this good
 This good cow

Instead of having a leftwards branching NP, we would have one that branches right wards as in:

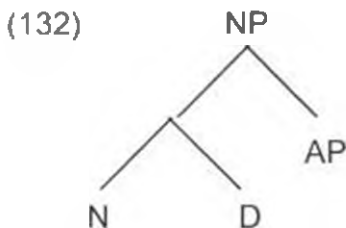

This representation strongly violates the x - bar theory, Under which we expect the adjective *Njega* to be base - generated as a complement, sister to its selecting head (*ng'ombe*). Recall that under x - bar syntax, lexical heads (such as, N) combine with complements to form X's. Since these two are supposed to be sisters, we therefore do not expect a demonstrative to come between a lexical head and its complement.

Under standard assumptions therefore, the surface word order of a Kikuyu NP cannot simply reflect that of the base. The noun-raising proposal provides a simple solution, since the noun and its complement are base-generated as sisters, and then separated by movement.

CHAPTER FIVE

SUMMARY AND CONCLUSION

5.1 SUMMARY

We have been concerned primarily with the question whether there is an AGR occupying a functional (i.e INFL-like) head position in the noun phrase.

Using data from the Kikuyu language we provided evidence that there is overt AGR in the noun phrase. This constituted a very strong case for adopting the position that the Kikuyu noun phrase is in fact a "DP" where "D" is a nominal functional element, the noun phrase equivalent of clausal INFL.

We argued that just as modal is the class of independent words (non-affixal) of category I, and complementizer the class of independent words of category C, the independent words of category D is the class of Determiners. This is in line with the X-bar syntax which states that every category must have lexical instantiations.

In agreement with Abney (1987) and Chomsky (1991) that the noun phrase and the clause are closely related, we proposed the following two structures for the clause and for the noun phrase.

(133)

(a) Sentence.

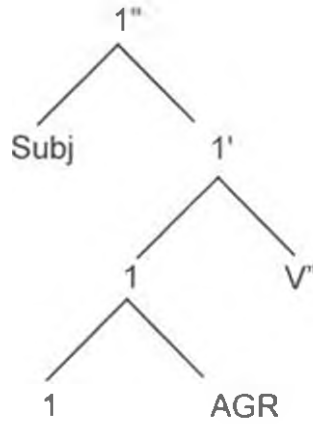

(b) Noun phrase.

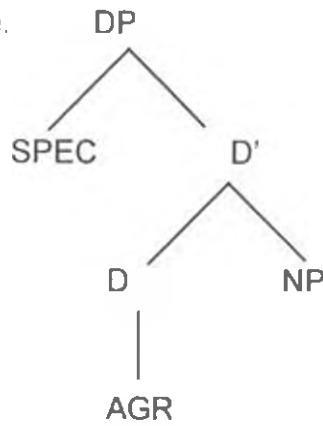

This argument was furthered by our proposal that just as the V in the sentences raises to 1, the noun in Kikuyu raises from its base position to the initial position for morphological feature checking.

Lastly we agreed with Carstens (1993) proposal that Noun class prefixes are added to nouns as number morphology, and that, gender is a lexical property of the nouns. She proposed that number itself is a functional head which selects NP complements. To Carsten's and so to us, this analysis makes possible a uniform treatment of number morphology on the one hand, and independent number words on the other, in the languages which have them.

5.2. CONCLUSION.

In chapter one, we stated that the basic concern of generative grammar has been to determine and characterize the Linguistic capacities of particular individuals. To further this concern, it is our sincere hope that this study will prompt further research by other scholars into studying more about the Determiner phrases and especially their structures when all the types of determiners co-occur with the noun.

BIBLIOGRAPHY

- Abney, S. (1987) The English noun phrase in its sentential aspect, unpublished doctoral dissertation, MIT.
- Austin, C. (1974) Aspects of Bukusu syntax and phonology, unpublished Ph. D. dissertation, Indiana university.
- Bach, E. (1974) Syntactic theory Holt, Rhirehart and Winston.
- Barlow A.R. (1960) Studies in Kikuyu Grammar and idiom, William Blackwood and sons, Ltd., Edinburgh.
- Chomsky N. (1957) Syntactic theory Hague mouton.
- _____ (1965) Aspects of the Theory of syntax. Cambridge, massachusetts, M.I.T.
- _____ (1982) Lectures on Government and Binding. Foris publications, Riverton U.S.A.
- Chomsky, M. and H. Lasnik (1991) Principles and parameters Theory. M.I.T.
- Carstens V. (1993) ON nominal morphology and DP structure
Mchombo S.A. Theoretical aspects of Bantu Grammar Ieland
stanford junior university.
- Cowper E.A. (1986) An introduction to syntactic theory. The
Government and Binding Approach, university of Toronto.
- Fukui N. (1986) A theory of category projection and its application, unpublished doctoral dissertation, M.I.T.
- Gicaga B. N. & Kirkaldy W. A short kikuyu Grammar London, Macmillan
(1943)
- Gatede A.W. (1991) NP and WH Movement in Kikuyu unpublished M.A
Dissertation, U.O N
- Guthrie M. (1948) The classification of Bantu languages. Oxford university press.

Haegeman L. (1991) Introduction to Government and Binding Theory, Lilliane Haegeman.

Horrocks G. (1987) Generative Grammar longman group Ltd.

Kaviti L.K. (1993) parametric variation in the acquisition of English as an additional language. unpublished M.A. dissertation, U.O.N.

Leaky L.S.B. (1959) First lessons in Kikuyu. The eagle press, Kampala.

Marete G.N. (1981) A study of Grammatical Agreement in Kimeru syntax. Unpublished M.A. dissertation, U.O.N.

Mutahi, K. (1977) Sound change and the classification of Dialects of Southern mt. Kenya. University of Nairobi PH.D. dissertation.

Mweri G. (1991) NP movement in Kigiriana. unpublished M.A. dissertation U.O.N.

Mweore A.N. (1987) The Kikamba noun phrase unpublished M.A. dissertation U.O.N.

Nyombe B.G.V. (1996) DP analysis of the Bari noun phrase unpublished paper, U.O.N.

Overton N.J. (1973) A Generative transformational grammar in kikuyu language based on the Nyeri dialect unpublished Ph.D dissertation U.O.N

Pollock J.Y. (1989) Verb movement, UG and the structure of IP. In Linguistic inquiry

Polome E.C. (1967) Swahili language Handbook. (Washington) centre for Applied linguistics.

Radford A. (1981) Transformational syntax. Cambridge university press.

_____ (1988) Transformational Grammar. Cambridge University Press.

Riemsdijk and Williams (1986) Introduction to the theory of Grammar. The Massachusetts Institute of Technology.

- Stockwell R.P. (1977) Foundations of syntactic Theory. University of California los Angeles, U S A.
- Ssewangi S.S. (1993) The syntax of Empty category in Kiswahili simple sentences. unpublished M.A. dissertation. U.O.N.
- Tang C.C.J. (1990) A note on the DP analysis of the Chinese noun phrase in LINGUISTICS an interdisciplinary journal of the language sciences, VOLUME 28-2.
- Thandi C.G. (1988) Pronominalization in Kiswahili, an approach the Binding Theory. unpublished M.A. dissertation U.O.N.