

STUDY OF ANTIMICROBIAL, PHYTOCHEMICAL AND TOXICOLOGICAL
PROPERTIES OF SELECTED PLANTS USED IN THE MANAGEMENT OF SEXUALLY
TRANSMITTED INFECTIONS IN SAMBURU COUNTY, KENYA.

IRENE THIGUKU KAMANJA (BVM, MSc)

J80/8150/09

A thesis submitted in fulfillment of requirements for the degree of Doctor of Philosophy in
Pharmacology and Toxicology of the University of Nairobi.

Faculty of Veterinary Medicine

University of Nairobi

2014

DECLARATION

This thesis is my original work and has not been presented for the award of a degree in any other University

Signed-----Date-----

Kamanja Irene Thiguku, BVM, MSc.

Department of Public Health, Pharmacology and Toxicology, University of Nairobi, Kenya

This doctoral thesis has been submitted for examination with our approval as University supervisors

Signed-----Date-----

Prof. J.M. Mbaria, BVM, MSc, PhD

Department of Public Health, Pharmacology and Toxicology, University of Nairobi, Kenya

Signed-----Date-----

Prof. P.K. Gathumbi, BVM, MSc, PhD

Department of Veterinary Pathology, Microbiology and Parasitology, University of Nairobi, Kenya

Signed-----Date-----

Dr. Mbaabu Mathiu, BVM, MSc, PhD

Department of Veterinary Anatomy and Physiology, University of Nairobi, Kenya.

Signed-----Date-----

Prof. S. G. Kiama, BVM, MSc, PhD

Department of Veterinary Anatomy and Physiology, University of Nairobi, Kenya.

DEDICATION

This thesis is dedicated to my loving family; my husband John Kamanja, my daughters Prudence Njeri and Immaculate Nyambura and my son Kevin Ngure.

To God be all the glory for great things He has done.

	PAGE
TABLE OF CONTENTS	
DECLARATION	ii
DEDICATION	iii
TABLE OF CONTENTS	iv
LIST OF TABLES	xii
LIST OF FIGURES	xiv
LIST OF APPENDICES	xvi
ACKNOWLEDGEMENT	xvii
ABSTRACT	xix
LIST OF ACRONYMS	xxiii
CHAPTER ONE: GENERAL INTRODUCTION	1
1.0 Introduction	1
1.1 Objective of the study	3
1.1.1 General objective	3
1.1.2 Specific objec	3
CHAPTER TW: LITERARURE REVIEW	5
2.1 Microbial infections	5
2.2 Sexually transmitted infections	6
2.3 Antimicrobial agents	6
2.3.1 Classification of antimicrobial drugs	7
2.3.2 Antimicrobial resistance	7
2.3.3 Mechanism of resistance	8
2.4 Ethnomedicine, ethnoveterinary medicine, and indigenous systems of	10

	medicine	
2.4.1	Ethnomedicine and ethnoveterinary medicine	10
2.4.2	Indigenous systems of medicine	13
2.4.2.1	Traditional African Medicine	13
2.4.2.2	Traditional Chinese Medicine	14
2.4.2.3	Traditional Indian Medicine	16
2.4.2.3.1	Ayurveda system	16
2.4.2.3.2	Siddha system	17
2.4.2.3.3	Unani Medicine	18
2.4.2.3.4	Yoga	20
2.4.2.3.5	Homeopathy system	20
2.4.2.3.6	Naturopathy system	22
2.4.2.4	Osteopathic medicine	24
2.4.2.5	Chiropractic medicine	24
2.4.2.6	Shamanism	26
2.5	Use of traditional medicine in treatment of microbial infections	27
2.6	Methods of testing for efficacy and toxicity of herbal medicine	29
2.7	Phytochemical constituents and extraction of bioactive ingredients	36
2.7.1	Extraction of bioactive ingredients	36
2.7.2	Phytochemical Constituents of phytomedicines	40
2.8	Classification of Organic Phytochemicals	41
2.8.1	Terpenoids	41
2.8.2	Alkaloids	41

2.8.3	Iridoids	41
2.8.4	Saponins	42
2.8.5	Steroidal saponins	42
2.8.6	Cardioglycosides	42
2.8.7	Phytosterols	43
2.8.8	Resins	43
2.8.9	Phenols	43
2.8.10	Additional phenolic compounds (Polyphenols)	44
2.8.10.1	Phenolic acids	44
2.8.10.2	Coumarins	44
2.8.10.3	Quinones	44
2.8.10.4	Flavonoids	45
2.8.10.5	Lignins	45
2.8.11	Tannins	46
2.8.12	Carbohydrates	46
2.8.13	Mucilages	46
2.8.14	Lipids	47
2.8.15	Proteins	47
2.9	Literature of some of plants studied	47
2.9.1	<i>Clerodendrum myricoides</i> (Hoechst) Vatke	47
2.9.2	<i>Acacia tortilis</i> (Hayne)	50
2.9.3	<i>Myrsine africana</i> L.	52
2.9.4	<i>Carissa edulis</i> (Vahl) with ripened fruit	54

2.9.5	<i>Rhamnus prinoides</i> (L, Herit)	56
2.9.6	<i>Rhamnus staddo</i> A. Rich	58
2.9.7	<i>Sansevierria ehrenbergii</i> Bach	60
2.10	The Samburu Culture	62
	CHAPTER THREE: ETHNOPHARMACOLOGICAL PRACTICES	63
	IN MANAGEMENT OF SEXUALLY TRANSMITTED INFECTIONS	
	IN SAMBURU COUNTY, KENYA	
3.1	INTRODUCTION	63
3.2	MATERIALS AND METHODS	64
3.2.1	Study area	64
3.2.2	Ethnopharmacological survey of indigenous knowledge and practices of Samburu people in management of venereal diseases	67
3.2.3	Collection and identification of plants used in management of STIs	68
3.2.4	Data analysis and reporting	68
3.3	RESULTS	68
3.3.1	The Samburu ethnodignostic skills	68
3.3.2	Biodata of Samburu Traditional Healers	69
3.3.3	Anti STI traditional herbal remedies of Samburu, Kenya	69
3.4	3.4 Discussion	74
	CHAPTER FOUR: PRELIMINARY PHYTOCHEMICAL	77
	SCREENING OF THE CRUDE EXTRACTS OF	
	CLERODENDRUM MYRICOIDES FROM SAMBURU	
	COUNTY, KENYA.	

4.1	INTRODUCTION	77
4.2	MATERIALS AND METHODS	78
4.2.1	Preparation of <i>Clerodendrum myricoides</i>	78
4.2.2	Preparation of aqueous extract of <i>Clerodendrum myricoides</i>	78
4.2.3	Preparation Methanol /water extract of <i>Clerodendrum myricoides</i>	79
4.2.4	Phytochemical screening	79
4.2.4.1	Test for alkaloids	79
4.2.4.2	Test for sterols and triterpenes	79
4.2.4.3	Test for saponins	80
4.2.4.4	Test for flavonoids and flavones	80
4.2.4.5	Test for tanins	80
4.2.4.6	Test for cardiac glycosides	80
4.2.4.7	Test for resins	81
4.2.4.8	Test for anthraquinones	81
4.2.4.9	Test for phenols (Ferric chloride test)	81
4.2.4.10	Test for glycosides	81
4.3	Results	81
4.4	Discussion	83
	CHAPTER FIVE: INVITRO ANTIMICROBIAL ACTIVITY OF SELECTED MEDICINAL PLANTS FROM SAMBURU COUNT, KENYA	86
5.1	INTRODUCTION	86
5.2	MATERIALS AND METHODS	87

5.2.1	Preparation of plants for extraction	87
5.2.2	Preparation of Chloroformic extract of selected medicinal plants	87
5.2.3	Evaluation of antimicrobial activity of selected medicinal plants	88
5.2.4	Data analysis	90
5.3	Results	90
5.3.1	Extraction efficiency (yield) of selected medicinal plants	90
5.3.2	The Minimum Inhibition Concentration of selected Medicinal plants	92
5.4	Discussion	94
	CHAPTER SIX: CYTOTOXICITY OF SELECTED MEDICINAL	96
	PLANTS EXTRACT FROM SAMBURU COUNTY	
6.1	INTRODUCTION	96
6.2	MATERIALS AND METHODS	97
6.2.1	Study area	97
6.2.2	Collection and identification of plants	97
6.2.3	Preparation of plants and plant extract	98
6.2.4	Evaluation of bioactivity for selected plants using brineshrimp lethality test	98
6.2.4.1	Hatching of Brine shrimp nauplii	98
6.2.4.2	Plant extracts solution preparation	98
6.2.4.3	Cytotoxicity bioassay	99
6.2.5	Data Analysis	99
6.3	Results	99
6.3.1	Cytotoxicity of aqueous extract	100
6.3.2	Cytotoxicity of methanol/ water extract	102

6.3.3	Cytotoxicity of chloroformic extract	104
6.4	Discussion	106
	CHAPTER SEVEN: STUDY OF ACUTE TOXICITY OF THE	108
	AQUEOUS EXTRACT OF <i>CLERODENDRUM MYRICOIDES</i>	
7.1	INTRODUCTION	108
7.2	MATERIALS AND METHODS	109
7.2.1	Laboratory animals	109
7.2.2	Dosing of animals	109
7.2.3	Pathology and Histopathology	110
7.2.3.1	Tissue processing for histopathology	110
7.2.3.2	Tissue staining	111
7.2.4	Data analysis	112
7.3	Results	112
7.3.1	Effects of aqueous extract of <i>C. myricoides</i> on rats	112
7.3.2	Pathology and Histology of the animals that died and those that survived for the two weeks test period	113
7.4	Discussion	116
	CHAPTER EIGHT: STUDY OF SUB ACUTE TOXICITY OF	117
	AQUEOUS EXTRACT OF <i>CLERODENDRUM MYRICOIDES</i>	
	(HOECHST) VATKE	
8.1	INTRODUCTION	117
8.2	MATERIALS AND METHODS	117
8.2.1	Laboratory animals	117

8.2.2	<i>Clerodendrum myricoides</i> aqueous extract	118
8.2.3	Treatment of animals	118
8.2.4	Body weight and food/water consumption	119
8.2.5	Haematology	120
8.2.6	Clinical Biochemistry	120
8.2.7	Pathological examination	120
8.2.7.1	Gross pathology	120
8.2.7.2	Histopathology	121
8.2.7.3	Data analysis	121
8.3	Results	121
8.3.1	Behavioral changes	121
8.3.2	The body weights of rats	123
8.3.3	Biochemical parameters	123
8.3.4	Haematological parameters	123
8.3.5	Gross pathology	128
8.3.6	Histopathology	128
8.4	Discussions	131
	CHAPTER NINE: CONCLUSION AND RECOMMENDATIONS	135
9.1	CONCLUSIONS	135
9.2	RECOMMENDATIONS	136
	REFERENCES	138
	APPENDICES	177

LIST OF TABLES	PAGE	
TABLE 4.1	THE PHYTOCHEMICALS PRESENT IN THE AQUEOUS AND METHANOL/ WATER EXTRACTS OF <i>CLERODENDRUM</i> <i>MYRICOIDES</i>	82
TABLE 5.1	EXTRACTION EFFICIENCY (YIELD) OF THE SELECTED MEDICINAL PLANT SPECIES IN WATER METHANOL/ WATER AND CHLOROFORM	91
TABLE 5.2	THE MINIMUM INHIBITION CONCENTRATION (MIC) MG/ML OF SELECTED MEDICINAL PLANTS AQUEOUS AND METHANOL/ WATER FROM SAMBURU COUNTY	93
TABLE 6.1	RESULTS OF BRINESHRIMP LETHAL ASSAY ON THE CRUDE AQUEOUS EXTRACTS OF SELECTED MEDICINAL PLANTS FROM SAMBURU COUNTY KENYA	101
TABLE 6.2	RESULTS OF BRINESHRIMP LETHAL ASSAY OF THE CRUDE METHNOL/ WATER EXTRACT OF SELECTED MEDICINAL PLANTS FROM SAMBURU COUNTY KENYA	103
TABLE 6.3	RESULTS OF BRINE SHRIMP LETHAL ASSAY OF CRUDE CHLOROFORMIC EXTRACTS OF SELECTED MEDICINAL PLANTS FROM SAMBURU COUNTY KENYA	105
TABLE 8.1	COMPARISON OF THE MEAN WEIGHT \pm SEM AMONG AQUEOUS EXTRACTS OF <i>CLERODENDRUM MYRICOIDES</i> TREATED GROUPS.	124
TABLE 8.2	MEAN ORGAN WEIHGT VALUES \pm SEM OF THE RATS OVER THE 28-DAY STUDY PERIOD	125
TABLE 8.3	CLINICAL BLOOD CHEMISTRY VALUES OF FEMALE AND MALE	126

RATS AT THE FOURTH WEEK OF TREATMENT

TABLE 8.4

HAEMATOLOGICAL VALUES OF FEMALE RATS IN THE SUB

127

ACUTE TOXICITY TEST OF THE AQUEOUS EXTRACT OF

CLERODENDRUM MYRICOIDES (HOECHST) VAHL

LIST OF FIGURES	PAGE
FIGURE 1	49
<i>CLERODENDRUM MYRICOIDES</i> (HOECHST) VATKE FROM SAMBURU COUNTY	
FIGURE 2	51
<i>ACACIA TORTILIS</i> (HAYNE) FROM SAMBURU COUNTY KENYA	
FIGURE 3	53
<i>MYRSINE AFRICANA</i> L. AND ONE OF THE OLDEST AND REKNOWN HERBALIST WITHIN THE SAMBURU COMMUNITY	
FIGURE 4	55
<i>CARISSA EDULIS</i> VAHL	
FIGURE 5	57
<i>RAHMNUS PRINOIDES</i> (L'HERT)	
FIGURE 6	59
<i>RHAMNUS STADDO</i> A. RICH	
FIGURE 7	61
<i>SANSEVIERRIA EHRENBERGII</i> BACH	
FIGURE 8	66
THE MAP OF KENYA SHOWING THE LOCATION OF SAMBURU COUNTY AND ITS ADMINISTRATIVE BOUNDARIES	
FIGURE 9	70
PERCENT MENTION OF THE PLANT PARTS USED IN MANAGEMENT OF SEXUALLY TRANSMITTED DISEASES BY SAMBURU TRADITIONAL HEALERS	
FIGURE 10	72
THE PERCENT MENTION OF THE PLANTS USED TO MANAGE SEXUALLY TRANSMITTED DISEASES BY TRADITIONAL HEALERSY THE SAMBURU	
FIGURE 11	73
THE PERCENT MENTION OF HOW <i>CLERODENDRUM</i> <i>MYRICOIDES</i> IS MIXED WITH OTHER PLANTS BY THE TRADITIONAL HEALERS TO TREAT SEXUALLY TRANSMITTED INFECTIONS	

FIGURE 12	PHOTOMICROGRAPH OF THE THE LUNG SHOWING CONGESTION AND VASCULITIS	114
FIGURE 13	PHOTOMICROGRAPH OF THE KIDNEY SHOWIN MILD CONGESTION	114
FIGURE 14	PHOTOMICROGRAPH OF THE SPLEEN SHOWING DEPOPULATION OF LYMPHOCYTES	115
FIGURE 15	MICROPHOTOGRAPH OF THE LIVER SHOWING CONGESTION	115
FIGURE 16	PHOTOGRAGHS OF RATS EXHIBITING CLINICAL SIGNS	122
FIGURE 17	A MICROPHOTOGRAGH OF THE HISTOLOGICAL SECTION OF THE SPLEEN SHOWING DEPOPULATION OF LYMPHOCYTES	129
FIGURE 18	A MICROPHOTOGRAPH OF THE HISTOLOGICAL SECTION OF THE KIDNEY SHOWING MILD CONGESTION	129
FIGURE 19	A MICROPHOTOGRAPH OF THE HISTOPATHOLOGICAL SECTION OF THE LIVER SHOWING MILD CONGESTION	130
FIGURE 20	A MICROGRAPH OF THE HISTOLOGICAL SECTION OF THE LUNG SHOWING OEDEMA AND VASCULITIS	130

LIST OF APPEDICES	PAGE	
APPENDIX 1	THE HERBALISTS WHO WERE INVOLVED IN THE STUDY AT SAMBURU COUNTY	177
APPENDIX 2	RESPONDENTS CONSENT AGREEMENT	179
APPENDIX 3	SEMISTRUCTURED QUESTIONNAIRE	180
APPENDIX 4	CLASSIFICATION ACCORDING TO THE ACUTE TOXIC CLASS METHOD.	183
APPENDIX 5	TABLE 3.1 PLANTS USED IN THE MANAGEMENT OF SEXUALLY TRANSMITTED DISEASES BY THE SAMBURU TRADITIONAL HEALERS.	184
APPENDIX 6	TABLE 3.2 PLANTS USED IN SAMBURU COUNTY AND THEIR PUBLISHED DATA ON THEIR ETHNOMEDICAL USES.	187
APPENDIX 7	TABLE 7.1 CLINICAL OBSERVATIONS DURING 24 HOUR PERIOD AFTER ORAL ADMINISTRATION OF AQEOUS EXTRACT OF CLERODENDRUM MYRICOIDES FROM SAMBURU COUNTY	192

ACKNOWLEDGMENT

This work was funded by the Carnegie Foundation of New York -Science Initiative Group through Regional Initiative in Science and Education (RISE-AFNNET) African Natural Product Training Network. Thanks to the Samburu Integrated Resource Aid Network (SIRAN) group at Maralal Samburu in Kenya, who organized the group of traditional healers and also the traditional healers group who fully participated in the ethnobotanical survey. University of Nairobi is acknowledged for infrastructural support, identification of the plant specimen and voucher specimen preparation.

Thanks to my supervisors, who with great commitment and sacrifice guided me through the whole programme; Prof. J.M. Mbaria, of the Department of Public Health, Pharmacology and Toxicology, Prof. P.K. Gathumbi, of the Department of Veterinary Pathology, Microbiology and Parasitology, Prof. S.G. Kiama, of the Department of Veterinary Anatomy and Physiology and Dr. P.M. Mathiu, of the Department of Veterinary Anatomy and Physiology.

The Department of Public Health Pharmacology and Toxicology is acknowledged for the great assistance in the work on extraction of the medicinal plants, antimicrobial susceptibility tests, the toxicological tests and especially the assistance with laboratory animals. I thank all the technicians who assisted in the laboratory tests; Mr. Francis Mainga, Mr. Francis Gitau, Mr. Gitao Nduhiu, Mr. Joseph Nderitu, Mrs Lucy Mwangi and Mr Kenneth Maloba. Thanks to Dorcus Nduati for the great assistance given during the data analysis.

The Department of Clinical Studies is acknowledged for the blood chemistry and haematological tests carried out. Thanks to Jane Onsongo and Jane Kamau the technicians who assisted in carrying out the tests.

The Department of Veterinary Pathology, Microbiology and Parasitology is acknowledged for the assistance given in Gross Pathology and Histopathology carried out. Thanks to the technicians Mr. John Kinyuru, Mr. John Mukiri and Mr Jackson Gachoka for the work carried out. Mr. Jackson Mugweru and Ruth Githinji are highly appreciated for the time they spent in both assisting and advice given during the procurement of various chemicals and other laboratory items. The Ministry of Livestock Development is acknowledged for allowing me to carry out this study by giving me a course approval.

ABSTRACT

According to World Health Organization (WHO), the traditional systems of medicine provide primary health care for over 80% of the world population. Antimicrobial resistance is now a major pitfall in the use of conventional antimicrobial drugs. Natural products used in Traditional Medicine (TM) may be used to combat multidrug resistant infectious diseases through careful elucidation and validation of their biological components that have novel mechanism of action. Use of medicinal plant remedies is of high importance in many African communities. The Samburu community in Kenya values traditional medicine administered by their traditional healers and this forms the most important means of treatment of diseases among the Samburu community. There are several reasons including Poor infrastructure and inadequate modern medical facilities that have made most pastoralist communities in Kenya to rely on herbal medicines.

The traditional remedies used in Traditional African Medicine (TAM) lack proper documentation and data on safety and efficacy generated through scientific methods. The current study was carried out to document the use of medicinal plants in management of sexually transmitted infections among the Samburu community in Kenya and to study the pharmacological and toxicological profile of selected medicinal plant extracts. The first part of the study was an ethnobotanical survey on the use of herbal remedies used for the treatment of venereal diseases. This was followed by preliminary phytochemical screening, antimicrobial activity, cytotoxicity studies and *in vivo* toxicological studies of selected plant extracts.

Data on use of plants for management of sexually transmitted infections was obtained through focused group discussions and administration of semi-structured questionnaires to the herbalists. The herbalists then identified the plants in situ; samples were collected and submitted to a herbarium for botanical identification and allocation of voucher specimen numbers. Data on identity of medicinal plants, herbal remedies preparation methods, herbalists views on effectiveness, safety, availability of plants, their use on sexually transmitted infections (STIs) and ethnodagnostic skills was entered into a computer package for descriptive statistical analysis.

Eight commonly used plant species in management of STIs as cited in the ethnobotanical survey were selected: *Clerodendrum myricoides*, (Hoechst) Vatke *Carissa eduli* (Forsk) vahl, *Acassia tortilis* (Fossk) Hayne, *Myrsine Africana* L., *Rhamnus staddo* A. Rich, *Rhamnus prinoides* L'herit, *Psiadia arabica* Jabb and Spach and *Sansevieria enhribergii* Bach.

Preliminary phytochemical screening of aqueous and methanol/water plant extracts was done using standard phytochemical techniques for determination of the presence of alkaloids, steroids, triterpines, tannins, flavanoids, flavones, phenols, glycosides, anthraquinones, proteins and resins.

The bioactivity (cytotoxicity) of methanol/water (70/30) v/v and chloroform extracts of the 8 plants was tested using the brine shrimp lethality test (BLT). Ten naupli were introduced in tubes containing various dilutions of the plant extracts and mortality after 24hrs recorded. Mortality data was entered into the Probit Method of Finney Computer Programme for determination of the lethal concentration (LC₅₀) and its 95 % confidence interval. The calculations were based on the number of dose level, the number of brine shrimp that died per concentration and % mortality per concentration.

The antimicrobial activities of the plant extracts against *Neisseria gonorrhoea*, *Staphylococcus aureus*, *Escherichia coli*, *Bacillus cereus* *Pseudomonas aeruginosa*, and *Streptococcus fecalis* using broth dilution technique were determined. These were compared with those of benzyl penicillin, oxytetracycline and streptomycin as positive controls in the experiment. The toxicity of the aqueous extract of *Clerodendrum myricoides* (Hoechst) Vatke was determined in rats using the Organization of Economic Corporation and Development (OECD) protocols for toxicity testing, acute toxic class method for acute toxicity and 28-day repeated dose method for sub acute toxicity testing.

Results of ethnobotanical survey showed that the ethnodagnosis of sexually transmitted infections (STIs) by the Samburu traditional healers was mainly based on symptoms. The commonly used plants species in management of STIs were roots of *Clerodendrum myricoides* (Hoechst) Vatke, (93%), *Carissa edulis* (52%), *Myrsine africana* L., (31%), *Rhamnus staddo* A. Rich, (24%), *Rhamnus prinoides* L'herit 17%), *Sansevieria enhribergii* Bach, (10%) and *Psiadia arabica* Jabb and Spach (10%). *Clerodendrum myricoides* (Hoechst) Vatke was ranked first in STIs management and is used alone or in combination with other plants. The remedy was

prepared as a decoction that was given orally. For treatment of chronic cases of STIs, *Clerodendrum myricoides* (Hoechst) Vatke is administered to the patient per rectum. The extract of *C. myricoides* was positive for tannins, triterpenoids, cardiac glycosides, phenolics compounds, saponins and resins. Alkaloids were present in the methanolic/water extract only. Results of BLT showed that all the aqueous extracts had an LC₅₀ equal to or higher than 1000µg/ml. All medicinal plants tested for *in vitro* antimicrobial were inhibitory to the growth of bacteria as either aqueous or methanol/water extract. The aqueous extract of *Clerodendrum myricoides* (Hoechst) Vatke showed a broad spectrum of activity against various microorganisms tested except *Streptococcus fecalis*. The methanolic/water extract of *Rhamnus prinoides* L'herit had a broad spectrum of activity against all microorganisms tested except for *Neisseria gonorrhoeae*. In the Acute Toxic Class Method at dosage 2000mg/kg body weight mortality occurred within 24 hours. None of the rats died within 24 hrs after administration of *C. myricoides* aqueous extract at 300mg/kg body weight.

Clinical signs of acute toxicity observed affected the respiratory, musculoskeletal and respiratory systems. The extract of *C. myricoides* was found to have an LD₅₀ of 1000mg/kg and was therefore classified as slightly toxic. The signs of sub acute toxicity of *Clerodendrum myricoides* were characterized by behavioural changes, dyspnoea, piloerection, huddling together and scratching. The body weights of the treated animals increased significantly as compared to the control group (P<0.05). The weights of organs differed significantly from those in the control group. Administration of the extract of *C. myricoides* affected the biochemistry and the haematological parameters of the experimental animals.

Gross and histopathology lesions were observed in the liver, lungs, kidney, heart muscle and spleen. Some biochemical changes observed were significant although they were not dose dependent. They included blood urea nitrogen and creatinine. Results of histopathological examination showed mild congestion in animals that received *C. myricoides* extract at the 300mg/kg dosage. Changes in Serum levels of Alanine aminotransferase (ALT) were observe but they were not dose dependent. The serum levels of Aspartate aminotransferase (AST) were within normal range. The histopathological changes observed within the liver were mild and included congestion. Results of haematological examination showed an increase in total white

blood cells (WBC) and neutrophils. The lymphocytes counts significantly reduced in the experimental animals compared to the control group ($P < 0.05$).

The survey showed that alone or in combination with other plants especially *M. africana* and *C. edulis* is considered as important medicinal remedy for STIs in the Samburu community. The plant contains several phytochemicals that are probably responsible for the medicinal value. This study also supports the medicinal use of the plants since the sensitivity tests revealed the plant extracts were active against most microorganisms. *C. myricoides* can be used as non cytotoxic drug although the toxicity results classified it as slightly toxic and probably the benefits of the plants outweigh the risk of toxicity.

Further studies on formulation, dosage standardization, efficacy, clinical trials and value addition are needed for minimization of the observed side effects while maintaining the claimed medicinal values of the extract. The herbalist should be encouraged and facilitated to develop products that can be subjected to evaluation for registration by regulatory authorities. The pharmacological and toxicological data generated in this study may form part of the dossier for such products.

LIST OF ACRONYMS

AMRO/PAHO: The WHO Regional Office for Central America

ALT: Alanine Aminotransferase

AST: Aspartate Aminotransferase

ATC Method: Acute Toxic Class Method

BA: Blood Agar

CAM: Complementary Alternative Medicine

EBM: Evidence Based Medicine

EFA: Essential Fatty Acids

FDA: US Food and Drug Administration

HIV/AIDS: Human Immunodeficiency Virus/ Acquired Immunodeficiency Syndrome

LARMAT: Land Resource Management and Agriculture Technology.

MHA: Muller Hinton Agar

NCCAM: American National Centre for Alternative and Complementary Medicine

OIE: Organisation Internationale de Epizootique

NCCLS: National Council for Clinical Laboratory Standard

NOAEL: No Observed Adverse Effect Level.

OECD: Organisation of Economic Cooperation and Development

PID: Pelvic Inflammatory Disease

RBC: Red Blood Cells

SIRAN: Samburu Integrated Resource and Aids Network

STI: Sexually Transmitted Infections

TCM: Traditional Chinese Medicine

THMP: Traditional Herbal Medicine Practitioners

TM: Traditional Medicine

UN: United Nations

UNAIDS: United Nations Aid in Development

UNCTAD: United Nations Conference on Trade and Development

WBC: White Blood Cells

WHO: World Health Organisation

WOHO: World Osteopathic Health Organisation

CHAPTER ONE

INTRODUCTION

1.1 Introduction

Medicinal plants have been used for treatment of disease of humans and animals since prehistoric time. The first accepted use of plants as healing agents was depicted in the cave paintings discovered in the Lascaux caves in France and radiocarbon-dated to 13,000-25,000 BC (Tyler and Foster 1999). It has been reported that animals evolved a tendency to seek out bitter plant parts in response to illness which contain secondary plant metabolites like tannins and alkaloids (Hutchings *et al.*, 2003). These metabolites have antiviral, antibacterial, antifungal and anthelmintic properties (Cindy and Houghton 2002). In addition to medicinal plants, the scope of herbal medicine is sometimes extended to include fungal and bee products, minerals, shells and animal parts (Acharya and Shrivastava 2008).

Complementary Alternative Medicine (CAM) is gaining popularity in many developed countries. Forty-two percent (42%) of the population in the US have used CAM at least once (WHO, 1998) and the use of at least one of 16 alternative therapies increased from 34% in 1990 to 42% in 1997 (UNCTAD 2000). The number of visits to providers of CAM exceeds by far the number of visits to all primary care physicians in the US (WHO, Geneva 1999 a; WHO, Geneva; 2002). The expenses for the use of CAM are exponentially growing in many parts of the world. The 1997 out-of-pocket CAM expenditure was estimated at US\$ 2.7 billion in the USA and the world market for herbal medicines based on traditional knowledge is now estimated at US\$ 60 billion (Breevort, 1998). Traditional Medicine (TM) is used globally and is rapidly growing in economic importance. In developing countries, TM is a readily accessible and affordable treatment. The WHO reports that TM is the primary health care system for 80% of the

population in developing countries. In Latin America, the WHO Regional Office for the Americas (AMRO/PAHO) reports that 71% of the population in Chile and 40% of the population in Colombia have used TM. The WHO indicates that in many Asian countries TM is widely used, even though Western medicine is often readily available, and in Japan, 60-70% of allopathic doctors prescribe TMs for their patients (WHO, 1999 b)

In Kenya, more than 1200 plants are described as medicinal from a flora of approximately 10,000 members (Kokwaro, 1993). The wide spread use of traditional medicine among both urban and rural population in Kenya could be attributed to cultural acceptability, efficacy against certain types of diseases, physical accessibility and affordability as compared to modern medicine. Kenyan traditional medical system is characterized by variation and is shaped by the ecological diversities of the country, socio-cultural background of the different ethnic groups as well as historical developments, which are related to migration, introduction of foreign culture and religion. In Kenya, the knowledge from herbalists is often passed secretly from one generation to the next through word of mouth (Gathuma, *et al.*, 2004). Herbal medicines are cheap and readily available in the pastoral areas like Samburu District of Kenya but lack sufficient scientific data on efficacy, therapeutic index, toxic effects and other pharmacological and toxicological properties to support their use (Gathuma, *et al.*, 2004). Ideally, information obtained from local people should be used within the communities of its origin to ensure that they benefit from their own knowledge. A selected remedy can be improved outside the community through pharmacological and clinical research and then be returned, “Value added” to its place of origin (Martin *et al.*, 2001).

Clerodendrum myricoides is widely used for medicinal purposes in some African countries including Ethiopia, Uganda, Rwanda and Congo among others (Getahun, 1976). It is recognized

by the Samburu tradition as an important ethno medical remedy for many ailments including venereal diseases especially gonorrhoea and syphilis (Nanyingi *et al.*, 2008). The plant is used alone or in combination with other plants but no detailed study has been documented on its antimicrobial, phytochemical and toxicological properties. Although the Samburu traditional healers use the plant as an important herbal remedial plant, they caution that it may cause acute poisoning in case of overdose. The traditional healers therefore advise that this herb should only be handled and administered by experienced traditional healers (Nanyingi *et al.*, 2008). The fact that it is used in treatment of gonorrhoea and other venereal diseases shows that it may possess antimicrobial activities. The caution that it is administered by experienced traditional healers suggests that it may be acutely toxic. There is no documented scientific study of antimicrobial spectrum, phytochemistry and toxicity of *Clerodendrum myricoides* used by traditional healers in Samburu, Kenya. This study screened the phytochemistry of *Clerodendrum myricoides*, investigated its acute and sub-acute toxicological profiles and its antimicrobial profile together with other plants used to manage sexually transmitted bacterial diseases in man used by the Samburu community. The study will build from the community knowledge on management of venereal diseases.

1.1 Objectives of the study

1.1.1 General objective

To screen the phytochemical composition, determine antimicrobial and toxicological profile of *Clerodendrum myricoides* obtained from Samburu, Kenya.

1.1.2 Specific objectives

i) To conduct an ethno-botanical survey of plants traditionally used in management of sexually transmitted infections among the Samburu community

- ii) To determine the *in vitro* antimicrobial activity of important medicinal plants used for treatment of sexually transmitted infections in Samburu County, Kenya
- iii) To carry out the preliminary phytochemical screening of the aqueous extract of *Clerodendrum myricoides*.
- iv) To determine the *in vivo* acute and sub-acute toxicity of the *Clerodendrum myricoides* aqueous extract in albino rats
- v) To determine the acute toxicity of *Clerodendrum myricoides* aqueous extract using the brine shrimp lethality test

CHAPTER TWO

LITERATURE REVIEW

2.1 Microbial Infections

Microbial infections are the invasion of the host body tissue by microbes which include bacteria, viruses, fungi and parasites. These infections are classified according to the invading microorganisms, the symptoms of disease and the duration of infection. There may be an unapparent infection with no symptoms of disease or apparent infection with clear symptoms. A short term illness is either per-acute or acute while a long term illness can be either sub-acute or chronic if present for quite a long duration (Verlag, 2005). Diagnosis of a disease can be achieved through the symptoms, the laboratory tests done using samples and case history (Bruehl, *et al.*, 2010). Diseases arise when either the host immune mechanism is compromised, or if the microbes release toxins or enzymes that damage the host tissues. Persistent infections occur if the host is unable to clear the primary infection while chronic infections account for quite a high mortality and morbidity (Bruehl, *et al.*, 2010).

Pathogens are usually transmitted from an existing reservoir to the host through various portals of entry which can be either direct; for example touch or indirect; where the organism can withstand adverse environmental temperatures. The entry can be through damaged skin or mucosa. Microbial infections are treated using antimicrobial agent that include antibacterial, antivirals, antifungals and antiprotozoal drugs while prevention may be achieved through proper hygiene, vaccinations and breaking the life cycle of parasites (WHO, 2010)

2.2 Sexually transmitted infections

These are illnesses with a significant probability of transmission between individuals by means of their sexual behaviour which involves vaginal intercourse, oral and anal sex. The global prevalence of these diseases is 8.5%. Some of them can be transmitted through use of intravascular needles, childbirth and breastfeeding. The infection may not necessarily show clinical symptoms and in case of chronic infection they may lead to pelvic inflammatory disease in women (Ronald, and Michelle, 2007). The causative agents of these diseases include; bacteria which cause Chancroid (*Haemophilus ducreyi*), Chlamydia (*Chlamydia trachomatis*), Gonorrhoea (*Neisseria gonorrhoeae*), Granuloma inguinale (*Klebsiella granulomatis*), and Syphilis (*Treponema pallidum*). The viral diseases include Viral hepatitis (*Hepatitis B virus*), herpes simplex (*Herpes simplex virus*), HIV (*Human immunodeficiency virus*), HPV (*Human papilloma virus*), Molluscan contagiosum (*Molluscan contagiosum virus*). Parasitic diseases include crab louse (*Phthirus pubis*), Scabies (*Sarcoptes scabiei*) while the protozoal disease is Trichomoniasis (*Trichomona vaginalis*). These diseases are easily transmitted through the mucous membranes which allow certain pathogens into the body as opposed to the skin (Ronald and Michelle, 2007). Treatment of these diseases is achieved by use of antibiotics including azithromycin, cefixime and metronidazole (Ronald, and Michelle, 2007).

2.3 Antimicrobial agents

Antimicrobials are drugs that are used to prevent and treat microbial infections. Their discovery started in the 19th century (1800 A.D) when the German scientist Paul Erlich discovered that Arsenic compounds could treat syphilis (users.ipfw.edu/blumenth/pharmweb/antibiotics.pdf). This was followed by the discovery of the penicillin by Alexander Fleming in 1928 in the 20th

century and the sulphur drugs were discovered by the German chemist Gerhard Domagk in 1932 (users.ipfw.edu/blumenth/pharmweb/antibiotics).

2.3.1 Classification of antimicrobial drugs

There are several modes of classification of antimicrobial drugs. They can be classified as antibacterial, antifungal, antiviral and antiparasitic depending on the type of microbe the drug targets. They are also classified based on their sources as natural; produced by bacteria and fungi (penicillin, cephalosporin, bacitracin, and polymixin), semisynthetic or synthetic drugs (<http://highered.mcgraw-hill.com/classware/infoCenter>). Antimicrobial drugs may be classified according to the range of microbes they act against such as broad spectrum antimicrobials which act on a wide range of microbes and narrow spectrum antimicrobials which act on a smaller range of microbes. These chemicals may also be grouped according to the site of action on the microbe. They may act to inhibit the cell wall synthesis, disrupt the plasma membrane, block protein synthesis, disrupt metabolic pathways and also by inhibiting the nucleic acid synthesis (<http://highered.mcgraw-hill.com/classware/infoCenter>).

2.3.2 Antimicrobial resistance

Antibiotic resistance is whereby some or all sub-populations of a microorganism are able to survive after exposure to one or more antibiotics; pathogens resistant to multiple antibiotics are considered multidrug resistant (MDR) or superbugs. Penicillin and third generation cephalosporins resistant gonococci including *N. gonorrhoeae* have made treatment of some STIs very difficult hence the search for other options of medication (www.who.int/drugresistant/, www.who.int/mediacentre/)

Kapil, (2005) reported that antibiotics are important in the treatment of microbial infections. Following their discovery there was drastic reduction in morbidity and mortality of diseases caused by microorganisms which led to great satisfaction in the medical field. However, misuse of these drugs by concentrating on curative measures at the expense of preventive measures resulted in development of resistance of microorganisms to these drugs. He also observed that the resistant strains had a survival advantage and spread through out the world.

2.3.3 Mechanism of resistance

Bacteria can resist antibiotics as a result of chromosomal mutation or by exchange of genetic materials, which carry resistance genes, through transformation, transduction or conjugation by plasmids (Opal, *et al.*, 2000). The mechanism of resistance to antimicrobial agents can be through; impermeability of the drug, alteration in target molecule, enzymatic drug modifications for example b-lactamase enzymes accounting for most of the resistance to penicillins and cephalosporins and efflux of drug from the bacterial cell (Rice and Bonomo, 1996).

Although both chromosomal mutations and genetic transfer can be responsible for the resistance acquisition, it is the transferable resistance which poses a great threat as it can achieve much larger dimensions due to wide and rapid dissemination. This transferable resistance is carried on R plasmids. A single plasmid can carry a number of genes coding for multiple drug resistance (Day, 1998). Evolution of multi drug resistant plasmids in pathogens came into existence after the introduction of antibiotics after 1940s. This supports the observation that the use of antibiotic itself has been responsible for emergence of resistance in the pathogenic bacteria in clinical practice (Kapil, 2005).

It has been reported by Kunin, *et al.*, (1973) that the most important factors responsible for emergence of antibiotic resistance include, lack of education. The combination of poverty and ignorance makes it easy for resistance development due to inability to buy adequate quantity of antibiotics or to reach qualified doctors for proper prescriptions of antibiotics. Hospital acquired infections where the selective pressure of antibiotics is the highest as the hospital bacteria are mostly multi drug resistant (Kapil, 1998). This may be due to the increase in hospital associated infections because of the disregard to standard isolation precautions in most of the busy hospitals with limited resources according to Kaplan, *et al.*, (1990). Use of antibiotics in agriculture or aquaculture for therapeutic, prophylactic and growth promoting purposes (Gustafson and Bowen, 1997, Willis, *et al.*, 1999). The presence of residual antibiotics in the flesh of animals may result in direct exposure of the consumers to these drugs. In addition, the presence of low levels of antibiotics may select for resistant bacteria in the intestines of animals intended for human consumption (Willis, 2000). Antibiotics resistant bacteria can also be found on fruits and vegetables due to spreading of sewage sludge on farm land or use of antibiotics directly on fruit and vegetable crops (Gustafson and Bowen, 1997). The presence of antibiotic resistant bacteria in fresh water sources has been documented from different parts of the world (Willis, *et al.*, 1999).

Selection of resistant organism in nature may result from the natural production of antibiotics by soil organisms, or contamination from animal feed or crops or waste products from treated animals or humans. Resistant organisms from farming practices may be transferred into rivers and other water sources through waste disposal system or by drainage or rain water from farm land (Gustafson and Bowel, 1997). All these factors contribute to the natural reservoirs of resistant genes which may provide a source of transferable genes. There is an increase in the use

of surface antibacterial agents over the years into healthy households. The antibacterial substances added to diverse household cleaning products are similar to antibiotics in many ways and they can also select out resistant strains (Levy, 2001).

Appropriate use of antibiotics will delay and in many cases prevent the emergence of resistance. Several approaches to proper use of antibiotics have been employed to address antimicrobial resistance as reported by Bonhoeffer *et al.*, (1997) and Scheld, (2003) including; using newer more potent antimicrobials in settings where resistance has emerged to an older agent, judicious and rationale use of antibiotics, effective hospital infection control programme and research in the field related to development of newer antibiotics.

2.4. Ethnomedicine, ethnoveterinary medicine and indigenous systems of medicine

2.4.1 Ethnomedicine and Ethnoveterinary medicine

It has been reported (www.naturalhealthschool.com/prepper-lesson-2-supplement.html) that since the beginning of humanity people relied on plants for treatment of diseases. Through traditional bioprospecting man discovered that some plants could be used as food, others as medicine while others were poisonous. Animals too use plants for self cure for example the jaguar eats leaves after glooming to remedy against furballs while dogs and cats eat grass to alleviate gastric distress and to dislodge parasites. Traditional knowledge was passed orally from generation to generation with each succeeding generation adding to or refining the knowledge. Each culture world over has thus developed a body of herbal knowledge as part of its tradition. The first written record of herbs used as medicine (Girish and Shridhar, 2007) was made by the Sumerians (present day Iraq), the Chinese and Indians about 5,000 years ago. In China a book “an herbal” was put together by the then King and it contained 300 herbal plants including ephedra, the source of ephedrine. Indian system of medicine or Ayurveda had its *materia medica*

comprising of between 500 and 760 herbal plants which are still in use today. The Greeks and Romans derived much of their herbal knowledge from these early civilizations and also from Babylon (present day Iraq) and Egypt. The Greek physician Hippocrates (460-377 BC) referred to as the father of medicine was an herbalist and is credited for writing that “Let your food be medicine and your medicines be food”. In the Middle Ages herbalism was furthered by Monks who grew and studied herbs together with translating the Arabic works on herbalism. When the European explorers came to South America they found the Native Americans already practicing herbalism although it was mixed with spiritism. In Africa, Australia and globally, herbal knowledge developed and has been part of the tradition, for example among others *Prunus africana* is useful for the treatment of prostate cancer, *Morinda citrifolia* is useful as an immuno stimulant while *Piper methysticum* is useful in promoting relaxation without causing dullness. Today herbs that are in use are being tested scientifically for safety and efficacy and spiritism is far removed from them. ([www.naturalhealthschool.com/prepper-lesson 2-supplement.html](http://www.naturalhealthschool.com/prepper-lesson-2-supplement.html))

Ethnopharmacy is defined as how different types of medicines in a given society are viewed and used (<http://www.wisegeek.com>). Although it concentrates on folk medicine, it also studies the origin of pharmaceuticals whether natural or manmade and how they have been accepted by the society as medically beneficial. It encompasses the study of the routes of administration and how effective they are in treating medical conditions. Ethnopharmacy also encompasses the society dynamics including diet, medical practices and religion among others that affect the perception of a given pharmaceutical by a given society. It includes the study of how traditional or folklore medicine can be blended with modern medicine to be more effective. It further explores how the marketing and sale of these products can be achieved. In respect of the foregoing Pieroni, *et al.*, (2002) conducted a study in Southern Italy where they analyzed the biological means

traditionally used in ethnomedicine of three communities in the vulture area. They reported various plants to have medicinal use in the communities. Other means with medicinal importance were derived from minerals, animals and industrial materials. They further reported that these means of medication were not all used either internally or externally but also as symbolic ritual objects in spiritual healing ceremonies.

A study was carried out by Yoney, *et al.*, (2010) among the Turkish migrants in London. This study reported that in the Eastern Mediterranean region traditional medicinal use has been accepted for centuries to manage both minor and major diseases. They recorded 13 chronic illnesses and 85 species of plants 18 of which had been mentioned more than 10 times. The citations depended on the knowledge of the Turkish Cypriot tradition and the United Kingdom or General western Herbal Medical Tradition. The study further reviewed the danger of loss of this knowledge among the young and therefore served as a repository of knowledge for use in the future. It recommended the need to develop information sources for use by health care practitioners so as to bring awareness on benefits and risks of these medical and health food products. In their review on anticancer drugs derived from plants, Heinrich and Bremner, (2006) discussed examples of anti cancer drugs including Camptothecin, Taxol and their derivatives and other drugs at the stages of clinical trials. They highlighted the requirement of modern research on natural products as outlined in the Convention on Biological Diversity (Rio Convention) and the overall approach in ethnobotanical research. They have discussed the importance of ethnobotanical driven anticancer research using phytochemical pharmacological studies based on traditional plant use. They have further emphasised the potential of chemopreventive agents derived from traditional food plants.

Ethnoveterinary medicine (EVM) has been defined as a holistic, interdisciplinary study of local knowledge and associated skills, practices, beliefs, practitioners and social structures involving the health care and husbandry of food, work, and income producing animals, with a view of practical development and application in livestock production and livelihood systems; and with the goal of increasing human well being through increased benefits from livestock rearing in a given community (McCorke, 1995). EVM and Ethnomedicine overlap in some parts of the world including the type of resources used, prevalence of use of resources, modes of administration of remedies, and ethnomedical techniques employed reports (McCorke and Martin, 1998). Studies of EVM can be justified as they generate useful information that can develop locally made remedies for treatment of livestock diseases. Validation of traditional knowledge has been carried out to verify the safety and efficacy of treatment as demanded by scientists reports (Gathuma *et al.*, 2004, Githiori, 2004). EVM can be a key veterinary resource and can be useful in adding new drugs to the pharmacopoeia.

2.4.2 Indigenous Systems of Medicine.

2.4.2.1 Traditional African Medicine

Traditional African medicine is a holistic discipline involving indigenous herbalism and African spirituality, typically involving diviners, midwives, and herbalists. Practitioners of traditional African medicine claim to be able to cure diverse conditions such as cancers, psychiatric disorders, high blood pressure, cholera, most venereal diseases, epilepsy, asthma, eczema, fever, anxiety, depression, benign prostatic hyperplasia, urinary tract infections, gout and healing of wounds and burns (Helwig, 2010). Diagnosis is reached through spiritual means and a treatment is prescribed, usually consisting of an herbal remedy that has not only healing abilities, but symbolic and spiritual significance. Traditional African medicine, with its belief that illness is

not derived from chance occurrences, but through spiritual or social imbalance, differs greatly from Western medicine, which is technically and analytically based. In the 21st century, modern pharmaceuticals and medical procedures remain inaccessible to large numbers of African people due to their relatively high cost and concentration of health centres in urban centres. In recent years, African medical practitioners have acknowledged that they have much to learn from traditional medical practice (www.yale.edu/africanow, Mokaila, 2001).

2.4.2.2 Traditional Chinese Medicine

Traditional Chinese medicine, also known as TCM, includes a range of traditional medicine practices originating in Asia, primarily in regions that are now part of China and Taiwan. TCM is a common part of medical care throughout East Asia, but is considered a complementary and alternative medical system (CAM) in much of the Western world. TCM therapy largely consists of Chinese herbal medicine acupuncture, tuī-nǎ massage and dietary therapy. It uses a scientifically incorrect "alternative anatomy" (Camillia, 2006) metaphysical principles that have no correlation to science based medicine, (Camillia, 2006, Felix and Bauer, 2006, Singh and Ernst, 2008,) and is fundamentally based on a conclusion from these principles that are inconsistent with scientific facts; that the blood is propelled by a supernatural force called qi whereas in science based medicine blood is propelled by the pumping of the heart. Traditional Chinese medicines play a major role in Chinese lifestyle that is substantially different than the role of medicines in the west. They are part of everyday and social life in Chinese society. Those that have been scientifically analyzed have sometimes been found to be either ineffective, make discoveries in science-based pharmacology or to contain dangerous toxins (Chun-Fa *et al.*, 2007).

Traditional Chinese medicine theory is based on ancient Daoist philosophical and religious concepts of balance and opposites (yin and yang), and other metaphysical belief systems. In evidence based medicine, disapproved theories are "continually being replaced with new ones", but in traditional Chinese medicine little has changed since antiquity and "the most current medical knowledge always had roots from many centuries" (Camillia, 2006). Chinese knowledge of the human body was based not on anatomical studies using dissection, but on an "alternative anatomy" (Camillia, 2006) based on astrological calculations and "complex associations with gods" (Camillia, 2006, Wikipedia). Ill health is believed to result from an imbalance between what are believed to be interconnected organ systems, with one organ system believed to weaken or overexcite others. TCM practitioners believe that plant and animal products, and minerals can be used to stimulate or calm particular systems and bring them into balance. It is believed that insertion of needles in points of the body (acupuncture) and burning points of the body (moxibustion) stimulates the systems directly along what TCM believes are metaphysical flow lines of qi "energy", and that these can also be stimulated by practices such as a special kind of massage and exercise. Astrological influences are also believed to affect qi flow in the body, for example, the alignment of homes with the planets and stars, and the year, month, day, and hour of birth (Camillia, 2006, Felix and Bauer, 2006, Singh and Ernst, 2008)

TCM has been subject to criticism regarding a number of issues: its lack of scientific basis (Camillia, 2006), its questionable effectiveness (Singh and Ernst, 2008) its medicines containing toxins(Chun-Fa *et al.*, 2007) its being used instead of proven science based medicines (Barret, 2007, Anonymous, 2005, Singh and Ernst, 2008) possible side effects of its treatment methods, the ecological impact on endangered species by creating a black market demand for ineffective

medicines made from animal part (Anonymous, 2005, Harding, 2006, ,Chen ,2009, Bensky *et al.*, 2004) and the superstitious beliefs it promotes (Singh and Ernst, 2008)

2.4.2.3 Traditional Indian Medicine

The system of medicines which are considered to be Indian in origin or the systems of medicine, which have come to India from outside and got assimilated in to Indian culture are known as Indian Systems of Medicine (Prasad, 2002). India has the unique distinction of having six recognized systems of medicine in this category which includes Ayurveda, Siddha, Unani and Yoga, Naturopathy and Homoeopathy. Though Homoeopathy came to India in the 18th Century, it was completely assimilated into the Indian culture and got enriched like any other traditional system hence it is considered as part of Indian Systems of Medicine (Prasad, 2002). Apart from these systems, there are large numbers of healers in the folklore stream who have not been organized under any category.

2.4.2.3.1 Ayurveda system

In India, Ayurveda is considered not just as an ethnomedicine but also as a complete medical system that takes into consideration physical, psychological, philosophical, ethical and spiritual well being of mankind. It lays great importance on living in harmony with the Universe and harmony of nature and science. This universal and holistic approach makes it a unique and distinct medical system. This system emphasizes the importance of maintenance of proper life style for keeping positive health. This concept was in practice since two millennium and the practitioners of modern medicine have now taken into consideration the importance of this aspect hence the WHO's concept of health propounded in the modern era closely agree with the concept of health defined in Ayurveda (Kurup, 2004). The basic foundation is the fundamental

doctrine according to which whatever is present in the Universe (macrocosm) should be present in the body (the microcosm). It has been conceptualized that the universe is composed of five basic elements named Earth, Water, Fire, Air and Space or Ether. The human body is derived from them in which these basic elements join together to form what are known as 'Tridoshas' (humors). These humors govern and control the basic psycho-biological functions in the body. In addition to these three humors, there exist seven basic tissues and three waste products of the body such as faeces, urine and sweat. Healthy condition of the body represents the state of optimum equilibrium among the three doshas. Whenever this equilibrium is disturbed, disease condition results. The growth and development of the body components depend on nutrition provided in the form of food. The food is conceptualized to be composed of the basic five elements mentioned above. Hence it is considered to be the basic source material to replenish or nourish the different components of the body after the action of bio-fire. The tissues of the body are considered as the structural entities and the humours are considered as physiological entities, derived from different combinations and permutations of the five basic elements (<http://www.indianmedicine.nac.in>).

2.4.2.3.2 Siddha system

Siddha system of medicine is practiced in some parts of South India especially in the state of Tamilnadu. It is closely related to Ayurveda yet it maintains a distinctive identity of its own. This system has come to be closely identified with Tamil civilization. The term 'Siddha' has come from 'Siddhi' - which means achievement. Siddhars were the men who achieved supreme knowledge in the field of medicine, yoga or meditation (Narayanaswamy, 1975). Before the advent of the Aryans in India a well-developed civilization flourished in South India especially on the banks of rivers Cauvery, Vaigai, and Tamiraparani among others. The system of medicine

in this civilization seems to be the precursor of the present day Siddha system of medicine. With time it interacted with the other streams of medicines complementing and enriching them and in turn getting enriched. The *materia medica* of Siddha system of medicine depends to a large extent on drugs of metal and mineral origin in contrast to Ayurveda of earlier period, which was mainly dependent upon drugs of vegetable origin.

According to the Siddha concepts matter and energy are the two dominant entities, which have great influence in shaping the nature of the Universe. Matter cannot exist without energy and vice-versa. Thus both are inseparable. The universe is made up of five proto-elements. The concept of five proto-elements and three doshas in this system of medicine is quite similar to Ayurvedic concept. However there are certain differences in the interpretation (Narayanaswamy, 1975).

2.4.2.3.3 Unani system

Unani medicine has its origin in Greece. It is believed to have been established by the great physician and philosopher- Hippocrates (460–377 BC). Galen (130–201 AD) contributed for its further development. Aristotle (384–322 BC) laid down foundation of Anatomy & physiology. Dioscorides - the renowned physician of the 1st Century AD made significant contribution to the development of pharmacology, especially of drugs of plant origin. The next phase of development took place in Egypt and Persia (the present day Iran). The Egyptians had well evolved pharmacy; they were adept in the preparation of different dosage forms like oils, powder, ointment and alcohol. (<http://www.indianmedicine.nac.in>).

The Arabian scholars and physicians under the patronage of Islamic rulers of many Arabian countries have played great role in the development of this system. Many disciplines like

chemistry, pharmaceutical procedures like distillation, sublimation, calcinations and fermentation were developed and refined by them. Jabir bin Hayyan (717–813 AD) a Royal physician of his time has worked on the chemical aspects; Ibne Raban Tabari (810–895 AD) is the author of the book- Firdous ul Hikmat and introduced concept of official formulary. Abu Bakar Zarakariya Razi (865–925 AD) has authored a book known as “Alhawi fit tibb”. He has worked in the field of immunology. Further more the name of Bu Ali Sina (Avicenna 980–1037 AD) is always referred in all matters related to Unani. He was a renowned global level scholar and philosopher. He had great role in the development of Unani medicine in the present form. His book Alqanoon or (The canon of medicine) was an internationally acclaimed book on medicine, which was taught in European countries till the 17th century. Many physician of Arab descent in Spain have also contributed to the development of the system. Abul Qasim Zohravi (Abulcasus 946 – 1036 AD) has authored the famous book on surgery “Al Tasreef”- (<http://www.indianmedicine.nac.in>). The Arabs were instrumental in introducing Unani medicine in India around 1350 AD.

According to the basic principles of Unani the body is made up of four basic elements i.e. Earth, Air, Water, Fire which have different Temperaments which include Cold, Hot, Wet, and Dry. They give rise, through mixing and interaction, to new entities. The body is made up of simple and complex organs. They obtain their nourishment from four humors namely- blood, phlegm, black bile and yellow bile. These humors also have their specific temperament. In the healthy state of the body there is equilibrium among the humors and the body functions in a normal manner as per its own temperament and environment. Disease occurs whenever the balance of humors is disturbed.

In this system also prime importance is given for the preservation of health. It is conceptualized that six essentials are required for maintenance of healthy state. They are Air, Food and drink, Bodily movements and response, Psychic movement and repose, Sleep and wakefulness and Evacuation and retention (Khaleefathullah, S. 2002).

The human body is considered to be made up of seven components, which have direct bearing on the health status of a person. They are Elements, Temperament, Humors, Organs, Faculties, and Spirits. These components are taken in to consideration by the physician for diagnosis and also for deciding the line of treatment (Khaleefathullah, S. 2002)

2.4.2.3.4. Yoga.

Yoga is a traditional meditative practice and physical and mental discipline originating in India. In a non-religious context, it is used as a form of meditation, a form of alternative medicine, and as a low-impact on physical exercise Yoga has been studied as an intervention for many conditions, including pain, stress, and depression. Both the meditative and the exercise components of yoga show promise for non-specific health benefits. Some yoga practitioners assert that yoga stimulates the flow of "life energy" and can treat a wide variety of diseases, illnesses, and complaints. (McCall, 2007).

2.4.2.3.5 Homeopathy system

Homeopathy is a form of alternative medicine in which practitioners treat patients using highly diluted (Ernest, 2002,) preparations that are believed to cause healthy people to exhibit symptoms that are similar to those exhibited by the patient. The collective weight of scientific evidence has found homeopathy to be no more effective than a placebo (Ernest, 2002, Altunc *et al.*, 2007, Shang *et al.*, 2005). While some individual studies have positive results, systematic reviews of published trials fail to demonstrate efficacy (Kleijnen *et al.*, 1991, Linde *et al.*, 1997,

Linde and Melchart 1998, Cucherat *et al.*, 2000, Mathie, 2003). Furthermore, higher quality trials tend to report results that are less positive, (Linde and Melchart 1998, Caulfield, 2005) and most positive studies have not been replicated or show methodological problems that prevent them from being considered unambiguous evidence of homeopathy's efficacy (Ernest, 2002, Altunc *et al.*, 2007, Linde *et al.*, 2001)

Depending on the dilution, homeopathic “remedies” may not contain any pharmacologically active molecules, (Ernst, 2005) and for such “remedies” to have pharmacological effect would violate fundamental principles of science (Shang *et al.*, 2005). Modern homeopaths have proposed that water has a memory that allows homeopathic preparations to work without any of the original substance; however, there are no verified observations or scientifically plausible physical mechanisms for such a phenomenon (Maddox *et al.*, 1988). The lack of convincing scientific evidence to support homeopathy's efficacy and its use of “remedies” lacking active ingredients have caused homeopathy to be described as pseudoscience, quackery, (Wahlberg, 2007, Atwood, 2003, Ernst and Pittler 1998) and a "cruel deception". (Hilly, 2008) Homeopathic “remedies” are safe at high dilutions recommended by Hahnemann, since they likely contain no molecules of the original substance, but they may not be safe at lower dilutions (Chakraborti *et al.*, 2003). Homeopathy has been criticized for putting patients at risk due to advice against conventional medicine such as vaccinations, anti-malarial drugs, and antibiotics (Ernst and White, 1995). The regulation and prevalence of homeopathy is highly variable from country to country. There are no specific legal regulations concerning its use in some countries, while in others, licenses or degrees in conventional medicine from accredited universities are required. In several countries, homeopathy is covered by the national insurance to different extents, while in some it is fully integrated into the national health care system. In many countries, the laws that

govern the regulation and testing of conventional drugs do not apply to homeopathic “remedies” (WHO, 2001b)

2.4.2.3.6 Naturopathy system

Naturopathy or naturopathic medicine is a medical system that focuses on the body's innate vitalistic ability to heal and maintain itself (Benedict, 2002). Naturopathic philosophy favors a holistic approach, and finding the least invasive measures necessary for symptom improvement or resolution, thus encouraging minimal use of surgery and unnecessary drugs. According to the Association of Accredited Naturopathic Medical Colleges, "Naturopathic medicine is defined by principles rather than by methods or modalities. Above all, it honors the body's innate wisdom to heal." (<http://www.aanmc.org/naturopathic-medicine/> 2011). According to the American cancer society naturopathy is an alternative health care system that uses various approaches including, herbs nutrition acupuncture manipulation of the body among others. (<http://www.cancer.org/treatment/treatmentsandsideeffects/complementaryandalternativemedicine/> 2010). The term "naturopathy" is derived from Greek and Latin and translated as “nature disease” (<http://nccam.nih.gov/naturopathy/D372.pdf>, 2007). Modern naturopathy grew out of the Natural Cure movement of Europe. (Brown, 1988, Langley, 2007). The term was coined in 1895 by John Scheel and popularized by Benedict Lust, (<http://www.ama-assn.org>) the father of USA naturopathy” (Baer, 2001). Beginning in the 1970s, there was a revival of interest in the United States and Canada in conjunction with the holistic health movement Baer, (2001)

Naturopathic practitioners are split into two groups, traditional naturopaths and naturopathic physicians (<http://nccam.nih.gov/health/naturopathy/>). Naturopathic physicians employ the principles of naturopathy within the context of conventional medical practices. Naturopathy comprises many different treatment modalities of varying degrees of acceptance by the

conventional medical community; these treatments range from standard evidence-based treatments, to homeopathy and other practices sometimes characterized as pseudoscience. Naturopathy is practiced in many countries, primarily the United States and Canada, and is subject to different standards of regulation and levels of acceptance. The scope of practice varies widely between jurisdictions, and naturopaths in unregulated jurisdictions may use the Naturopathic Doctor designation (<http://medicalboard.iowa.gov/policies/naturopathy.htm>). The philosophical and methodological underpinnings of naturopathy are sometimes in conflict with the paradigm of evidence-based medicine (EBM) Jagtenberg *et al.*, 2006. Naturopaths have opposed vaccination based in part on the early philosophies that shaped the profession (Ernst, 2001)

2.4.2.4 Osteopathic Medicine

Osteopathy and osteopathic medicine are often used inter-changeably (<http://en.wikipedia.org>) Doctors of osteopathy are medical physicians who, in addition to their medical training, are also trained in musculoskeletal medicine, as well as manipulation. Osteopathic medicine in the United States is a complete system of medical training (MD), much like the allopathic (MD) training in the US or the British system of medical education, with all of the medical and surgical specialties and subspecialty (<http://www.osteopathic.org>). Osteopathic students study more of musculoskeletal system and osteopathic medicine as it relates more to the health of their patients. Disease prevention is central in their philosophy where there is an emphasis on treating the whole person body, mind and spirit, rather than just the symptoms. (<http://www.law.cornell.edu>) There is an international organization for individuals, the World Osteopathic Health Organization (WOHO), (<http://www.woho.org/>) which permits membership by both 'restricted scope manual therapist' osteopaths and 'full scope of medical practice' osteopathic physicians.

Similarly, there is also an international organization for national osteopathic and osteopathic medical associations, statutory regulators, and universities/medical schools offering osteopathic and osteopathic medical education, known as the Osteopathic International Alliance (OIA) (<http://www.oialliance.org>).

2.4.2.5 Chiropractic system

Chiropractic is a health care discipline and profession that emphasizes diagnosis, treatment and prevention of mechanical disorders of the musculoskeletal system, (Keating, 2005) and nervous system (Nelson, *et al.*, 2005). It is generally categorized as complementary and alternative medicine (CAM), a characterization that many chiropractors reject (Redwood, *et al.*, 2008). Meeker and Haldeman, (2002) noted that although chiropractors have many attributes of primary care providers, the practice has more of the attributes of a medical specialty like dentistry or podiatry. The main chiropractic treatment technique involves manual therapy, including manipulation of the spine, other joints, and soft tissues; treatment also includes exercises and health and lifestyle counseling (Mootz and Shekelle 1997). Traditional chiropractic assumes that a vertebral subluxation or spinal joint dysfunction interferes with the body's function and its innate intelligence, (Keating, 2005) a vitalistic notion that "brings ridicule from the scientific and health care communities and confusion within the chiropractic profession." (Keating *et al.*, 2005 a) Palmer, D.D. founded chiropractic in the 1890s and his son Palmer, B. J. helped to expand it in the early 20th century (Martin, 1993) It has two main groups: "straights", now the minority, emphasize vitalism, innate intelligence and spinal adjustments, and consider vertebral subluxations to be the cause of all disease; "mixers" are more open to mainstream and alternative medical techniques such as exercise, massage, nutritional supplements, and acupuncture (Kaptchuk and Eisenberg 1998). It is well documented that Chiropractic is established in the

U.S., Canada and Australia and is the third largest health profession, behind medicine and dentistry (<http://gateway.nlm.nih.gov/MeetingAbstracts/ma?f=102184948.html>). Throughout its existence, chiropractice has been area of controversy (Homola, 2006, DeVocht, 2006). For most of its existence it has battled with mainstream medicine, sustained by pseudoscientific ideas such as subluxation and innate intelligence (Keating *et al.*, 2005 b) that are not based on solid science (Ernst, 2008). In spite of the general consensus of public health professionals regarding the benefits of vaccination, among chiropractors there are significant disagreements over the subject, (Busse, *et al.*, 2005) which has led to negative impacts on public vaccination and mainstream acceptance of chiropractice. The American Medical Association called chiropractice an "unscientific cult" (Johnson *et al.*, 2008) and boycotted it until losing an antitrust case in 1987 (Cooper and McKee 2003). Chiropractice has had a strong political base and sustained demand for services; in recent decades, it has gained more legitimacy and greater acceptance among medical physicians and health plans in the U.S., (Cooper and McKee 2003); evidence-based medicine has been used to review research studies and generate practice guidelines (Villanueva-Russell, 2005).

It has been reported that conflicting results have been documented after the study of the various treatment methods used in chiropractice. It has been collectively concluded that, manual therapies commonly used by chiropractors are only effective for the treatment of low back pain, neck pain, some forms of headache and some extremity joint conditions (Bronfort *et al.*, 2010). Chiropractic care is generally safe when employed skillfully and appropriately (WHO, 2005). Spinal manipulation is frequently associated with mild to moderate adverse effects, with serious or fatal complications in rare cases (Ernst, 2010). A systematic review found that the risk of death from manipulations to the neck outweighs the benefits (Ernst 2010).

2.4.2.6 Shamanism system.

Shamanism

is an anthropological term referring to a range of beliefs and practices regarding communication with the spiritual world (Hoppál, 1987). Shamans are said to treat ailments/illness by mending the soul. Alleviating traumas affecting the soul/spirit restores the physical body of the individual to balance and wholeness. The shaman also enters supernatural realms or dimensions to obtain solutions to problems afflicting the community. Shamans may visit other worlds/dimensions to bring guidance to misguided souls and to ameliorate illnesses of the human soul caused by foreign elements. The shaman operates primarily within the spiritual world, which in turn affects the human world. The restoration of balance results in the elimination of the ailment

2.5 Use of Medicinal plants in treatment of microbial infections.

Herbalism is a traditional medicinal or folk medicine practice based on the use of plants and plant extracts. Herbalism is also known as botanical medicine, medical herbalism, herbal medicine, herbology, and phytotherapy. The scope of herbal medicine is sometimes extended to include fungal and bee products, as well as minerals, shells and certain animal parts (Acharya, *et al.*, 2008).

Many plants synthesize substances that are useful to the maintenance of health in humans and other animals. These include aromatic substances, most of which are phenols or their oxygen-substituted derivatives such as tannins. Many are secondary metabolites, of which at least 12,000 have been isolated and a number estimated to be less than 10% of the total. In many cases, these

substances (particularly the alkaloids) serve as plant defense mechanisms against predation by microorganisms, insects, and herbivores. Many of the herbs and spices used by humans to season food yield useful medicinal compounds (Fabricant and Farnsworth, 2001, Lai and Roy, 2004).

A wide range of chemical and natural compounds are used as antimicrobials. Organic acids are used widely as antimicrobials in food products, e.g. lactic acid, citric acid, acetic acid, and their salts, either as ingredients, or as disinfectants. For example, beef carcasses often are sprayed with acids, and then rinsed or steamed, to reduce the prevalence of *Escherichia coli* O157:H7 (<http://www.purac.com/purac>)

Traditional healers have used plants for long to prevent or cure infectious diseases. Many of these plants have been investigated scientifically for antimicrobial activity, and a large number of plant products have been shown to inhibit the growth of pathogenic microorganisms. A number of these agents appear to have structures and modes of action that are distinct from those of the antibiotics in current use, suggesting that cross-resistance with agents already in use may be minimal. Essential oils from plants have also been found to have bacterisostatic activity. So, it is worthwhile to study plants and plant products for activity against micro-organisms. (Smith *et al.*, 1998)

Herbal products have gained popularity over the past few years. In the United States of America 20% of the population use them. Here herbs are defined as dietary supplements in the law hence they are not required to be subjected to efficacy and safety procedures as the pharmaceutical drugs. Despite herbs being regarded as natural and hence safe, there have been reports by several authors of side effects due to active ingredients, contaminants or interactions with drugs (Ernest and Pittler, 1998, Martinez and Schmeiser., 2000, Ang Lee and Yuan., 2001, De Smet, 2002, Bent *et al.*, 2003, Stickel *et al.*, 2005). There is little scientific evidence to establish the

safety and efficacy of herbal products. Some products may have scientific evidence suggesting efficacy but lack of evidence on safety and considering other drug therapies may cause people not to use herbal remedies. (US office of the inspector general HHS, 2001). The limitation for the success of herbal products lies in there being a change in regulation, standardisation and funding for research of the herbal products (Bent, 2008). Further an understanding of the composition, regulation, safety and efficacy of herbal products can help clinicians in advising their patients who can be in a position to choose either alternative or allopathic medicine (Harkey *et al.*, 2001). An herb being any part of the plant or plant product (leave, stem, fruit, seed, and root) can be sold raw or extracted with a given solvent to give various phytochemicals (fatty acids, sterols, flavonoids, and saponins among others). As a given plant contains multiple chemicals some manufacturers attempt to create a standardised herbal product by identifying a “suspect” active ingredient and altering the process to obtain a consistent amount of the chemical. This is usually done using the High Performance Liquid Chromatography method (HPLC) (Bent, 2008). In herbal medicine the exact chemical or a combination of chemicals giving a given biological effect is not known and getting an exact chemical to give a desired effect may not be possible. The complication of varying techniques that can be used give differing results as reported by Rubber and Kanfer, (2004). It would therefore not be clear if a combination of chemicals would give a superior effect to one chemical use or not. Further scientific evidence of efficacy often suffers from poor methodology, inconsistent outcome measures, difference in herb preparation, and conflicting results (Bent, 2008).

2.6 Methods of testing efficacy and toxicity of herbal medicine

Herbal medicines or natural products are chemical compounds or substances produced by living organisms that usually have a pharmacological or biological activity for use in the

pharmacological drug discovery and drug design. These products may be useful pharmacologically but others may produce toxicity of adverse effect to the body of the organism (animal, plant, and bacterium) or to the substructure of the organism (cell of an organ). Some may show toxicity to pernicious cells or materials. Natural products may show dual roles depending on the target for treatment (Fang, 2010). Bent and Neuhaus, 2004) reported that Herbal medicines are often mistakenly regarded as safe because they are natural but these products usually contain bioactive principles that are potentially toxic. This makes it necessary for natural products to be subjected to the same efficacy and safety tests by the same methods used for new synthetic drugs (Talalay and Talalay, 2001).

Herbal medicines vary in toxicity from relatively safe which can be taken without causing any undesirable effect to potentially lethal which demand extreme caution at the time of dosing since any excess may lead to adverse effects or even death (Corns, 2003). Substances can be classified as extremely toxic if the LD₅₀ is less than 1mg/kg bwt, highly toxic when the LD₅₀ is between 1 and 50 mg/kg bwt, moderately toxic when the LD₅₀ is between 50 and 500mg/kg bwt, slightly toxic when LD₅₀ is between 500 and 5000 mg/kgbwt, practically non toxic when LD₅₀ is between 5000 and 15000 mg/kgbwt and relatively harmless when LD₅₀ is greater than 15000mg/kg bwt (Matsumura, 1975, Clarke and Clarke 2007).

During toxicity studies daily clinical observations of the test animals are of major importance as well as the final observation or end point in repeated dose application (Ferez *et al.*, 2006). The body weights act as an indicator of adverse side effects as the animals that survive cannot loose more than 10% of the initial body weight (Teo *et al.*, 2002, Obici *et al.*, 2008). The organ weight changes are also important indices of toxicity in animals which are readily determined in short

term toxicity tests. There is a high possibility that when herbal products are ingested into the human body may affect important organs such as the liver, kidney, lung, stomach, spleen, and intestines due to their diverse role in the human body; it then follows that the evaluation of the histopathological changes of these organs and others remains a cornerstone in the safety assessment of medicines (Greaves, 2007).

Additionally blood parameters analysis is relevant to risk evaluation. The haematological system has a higher predictive value for toxicity in humans (91%) when assays involve rodents and non rodents (Olson *et al.*, 2000). Biochemical parameters evaluations are important because there are reports of liver and kidney toxicity related to the use of phytotherapeutic products (Corns, 2003, Rhiou *et al.*, 2008).

In their IUPAC technical report of 2008, Mosihuzzaman and Choudhary define efficacy of herbal medicine as the measure of its ability to improve health and well being and its assessed by the clinical , laboratory or diagnostic outcome while Ronald and Torgeson, (1998) define efficacy as the benefit a treatment produces under ideal condition often using carefully designed subjects. Fabio and Luigi (2007) propose that for efficacy to be studied realistically, explanatory trials need to be carried out. These include randomised studies where control or placebo should be used and standardised protocols should be followed. Chawau *et al.*, (2006) further state that DNA microarrays can be used in pharmacodynamics for drug discovery, in pharmacogenomics for prediction of side effects and in pharmacognosy for correct botanical identification and authentication of crude plant materials as part of standardisation and quality control.

Further Mosihuzzaman *et al.*, (2008) have given details on the protocol for assessing the efficacy of herbal medicine which include; first Anecdotal reports; these are gathered from the traditional

healers and the people already using the herbal medicine in the communities. These are then organised in to case series to get useful data on the herbal agents being used. Secondly case reports which can be collected from published work on the herbal medicine in use. These are available from peer reviewed journals. The data collected can provide identification of new cases, new interventions or previously unknown adverse effects. Thirdly cases series which involve collection of individual case reports which can be organised to explore a given association. Lastly randomised clinical trials where double blinded (placebo controlled) trials are important. In the latter more resources are needed as more patients found in one and in different centers will be involved in the study. The foregoing should be broken down in terms of case study, case series study, animal experiment study, invitro experiment study, uncontrolled clinical trials and controlled clinical trials (Mosihuzzaman *et al.*, 2008).

As it has been reviewed by Ifeoma and Salawu, (2013) plants generally synthesise phytoprotectants to enable them survive adverse conditions. These are used in case of damage by herbivores pathogens or nutrient depletion. Some have been related to carcinogenic and ties in nephrogenic activities in man. Some plants may contain high levels of toxic heavy metals including mercury, cadmium, arsenic and lead among others. Saponins may disrupt lipid rich red blood cell among other effects.

Preclinical trials are carried out in animal tests (*in vivo*) and non animal tests (*invitro*). Extracts of herbal medicines are used in this way. Cell based cytotoxicity tests are carried out to predict potential toxicity using cultured cells. The goals of toxicity testing include identifying adverse side effects and the limit of exposure level where the effects occur, the nature and significance of adverse effects and the risks involved in the target population. In drug development toxic

compounds can be detected in either preclinical or clinical trials which may assist either in their removal or modification to improve their tolerability (Ifeoma and Salawu, 2013).

Cell based tests (CTAs) involve short term exposure of extracts to cultured cells. This helps to detect how basal or specialised cells may be affected by substances before performing tests in whole organisms. They help test carcinogenic and genotoxic effects of the extract. In these tests solvents for extraction should be ascertained that they are not toxic. Some cell lines include normal cells of primary origin for example rodents are used, permanent cell lines of high quality and reproducible over time for example mouse fibroblast cell lines BALB/C 3T3, Syrian Hamster Embryo cells (SHE). These predict genotoxicity and carcinogenicity and are highly predictive (Mosmann, 1983; Ifeoma and Salawu, 2013).

Herbal toxicokinetics deals with the prediction of toxicity due to pharmacokinetics of the herb or purified chemicals from it. It starts by using human liver microsomal cytochrome P450 isoforms. These help to identify any metabolites known to cause toxicological modulation at any level of cellular organization. In vitro metabolic data can be used to predict in vivo metabolic activity of the extract. Toxicogenomic screening tools measure potential toxic results of herbal compounds interaction at the molecular level. It aims at highlighting the molecular mechanism involved in expression of toxicity and derives molecular patterns (biomarkers) that can predict toxicity or individuals susceptible to it. Three main aspects are involved viz; DNA microarrays which provide clear prediction of cellular response to chemical toxicant. Proteomics which help identify proteins which are closer to toxicology endpoint and metabonomics which evaluates toxicity through large scale analysis of metabolic profiles. High throughput Next Generation Sequencing is the creation of large volumes of DNA sequences. It has enabled creation of large

genetic databases of plants. Animal tests are assumed to be more closely related to human toxicity as the system involves the pharmacokinetic aspects of metabolism, distribution and absorption of the test substance hence it is given through routes similar to its intended use. It also involves similar physiological events that influence toxicity. The animal system measures critical toxicity manifested as signs on gradual increase in the dose of test. The main drawbacks include the high cost of animals, species difference which affect the results and the test period which may prove to be quite tedious (Ifeoma and Salawu, 2013; www.gth.org).

General tests that are common have been harmonised by the Organisation for Economic Cooperation and Development (OECD) so as to internationally harmonise test guidelines. Several factors are considered before safety studies are conducted including; the preparation of test substance which may be in form of tablets, capsules, ointment creams among others. These are usually standardised based on intended use in man. Animal welfare is important and clinical signs should be used as endpoints determination. The animals used are equally of significance, where different rodents and non rodents species are used. In chronic studies species and strain of the animals should be justified. The animals should be housed properly. Regulatory requirements should be adhered to. Among the general tests used include Acute Systemic Toxicity which measures the relative toxicological response of an experimental organism to a brief single exposure to test substance.

The test organisms range from simple systems like Brineshrimp to large organisms like rats, mice, guinea pigs and rabbits. The test also helps to calculate the Median Lethal Dose (LD_{50}) using standard methods like Corke and Acute Toxic Class among others. Exposure routes include oral gavage, dermal, inhalation or injection. Animals are observed for 30 minutes

periodically within 24 hours and especially the first 4 hours and once daily for 14 days to be able to observe delayed toxicities. Data generated include feed intake, water intake, body weight measurements, serum biochemical parameters, haematological factors, gross pathological lesions and histopathological data. The liver and kidney have been reported mostly with injuries as the liver acts as a detoxifying organ and the kidney as a conduit for excretion of many chemicals (Lorke, 1983; OECD, 1998; OECD, 2001a; Ifeoma and Salawu, 2013).

In chronic toxicity or carcinogenicity studies a large number of animals are used. The test period may be from 24 months or a life time. The routes used include oral, dermal and in halation depending on the intended use in humans. Carcinogenicity and mutagenicity are revealed including the target organs by the substance. Important data include the lowest dose at which no toxicity occurs, no observable adverse effect level, mortality, food and water intake, hematology, clinical biochemistry, gross pathology and histopathology. OECD guidelines are strictly followed. The tests carried out include, specialised tests which are designed to reveal specific toxicities including reproductive, developmental, eye and skin irritant (Draize) test, neurotoxicity and genotoxicity. Clinical trials are also carried out in human participants and are grouped into four phases. In phase I a minimum number of subjects are used to assess the impact of use of the herbal remedies on various physiological indices. It determines the safety and maximum tolerable doses. It is usually done in healthy subjects. In phase II few subjects are used and it determines clinical efficacy (feasibility studies). Relatively safe doses are used and participants are monitored for adverse effects. In phase III a large number of humans are used in different centres. It is a randomised study, double blind controlled clinical trial. The test validates clinical efficacy of the herbal product and it is compared with a standard intervention. In phase IV there is post marketing surveillance. This monitors for rare side effects that may have been missed in

the first three trials that may occur when the product is already in the market (Ifeoma and Salawu, 2013; OECD).

Justification for the clinical trials should be provided using WHO guidelines. These include Chemistry Manufacturing Control; herbs have a wide range of composition and hence markers or fingerprints should be used for standardisation according to WHO standards. Non clinical considerations which involves collecting data on efficacy, safety and toxicity. Here Published data should be searched to identify gaps that can be bridged using the proposed clinical trials. Clinical considerations by keeping ethics and quality standards are important for example adverse effects for the proposed doses should be noted, the age, gender, health status parameters are equally important. The standard intervention is usually the product. Ethical considerations are mandatory including clearance by the ethical board in the region where trials are being performed, Good clinical practice should be adhered to, an informed consent of all participants must be obtained and experienced ethical investigators should be involved so that any effects or risks occurring may be countered immediately and effectively (Ifeoma and Salawu, 2013).

2.7 Phytochemical Constituents and extraction of bioactive ingredients

2.7.1 Extraction of bioactive ingredients

In the book *The Healing Power of Rainforest Herbs* (Taylor, 2004) it has been reported that extraction methods are usually standardised but vary with the plant being used and the disease being treated. These methods include fusions or hot teas; which are used for delicate herbs, leaves or fresh tender plants. The material is put in a container with water that has been boiled and covered for 10 to 15 minutes. Then this is sieved or strained and is ready to be taken. Decoctions which are used in case of tougher materials like the bark or the roots are boiled in

water for 20 minutes sieved or strained and are ready to be taken. Stronger decoctions are obtained after boiling the material for a longer time like 2 hours (Taylor, 2004). Tinctures are made by mixing the material with alcohol in the ratio of 1:4 for two weeks. This is usually shaken after 3 days to allow the principle constituents out of the plant. This is then filtered or decanted after standing and is ready for use. This product has a shelf life of up to 2 years. Maceration is where the herb is soaked in water overnight. The method is used if the active principles can be degraded by heat or alcohol. Poultices are made by chewing the herb, crushing the herb or using mortar and pestle to grind the herb. The material obtained is put on the sick part of the skin for example a wound. Compresses are made by soaking a piece of cloth in a decoction, infusions or a tincture. The cloth is then applied on to the sick part of the skin. Baths and bathing remedies is when herbs are added in the bathing water and the patient soaks in it. This relies on the fact that the skin can absorb the active principles. In this book the author reports that the methods are used by the traditional healers and can be used by the community at large (Taylor, 2004).

In their Publication, Handa *et al.*, (2008); Ankit *et al.*, (2012); have defined extraction as separation of medicinally active portion of plant or animal tissue from inert components. This is done by using selective solvents in standard extraction procedure. These extracts are relatively impure liquids, semisolids or powders for oral or external use. Standardisation aims at getting the therapeutic portion and eliminates inert material using a selective solvent (menstruum). This gives tinctures and fluid extracts. These can be further processed into tablet or capsule form or fractionated to give individual chemicals like hyoscine, vincristine among others which are modern drugs.

In this publication various methods of extraction of herbal medicines which can be used for small scale and large scale production of herbal drugs have been reported ((Handa *et al.*, 2008; Ankit *et al.*, 2012). These methods include; maceration where whole or coarsely powdered crude drug is placed in a stoppered container and allowed to stand at room temperature for 3 days, with frequent agitation until soluble matter dissolves. The mixture is then strained, the marc is pressed and the combined liquid is clarified by filtration or decanting after allowing it to stand for some time.

Infusions are fresh solutions of readily soluble constituents of crude drug which are prepared by macerating crude drug for a short period of time with cold or boiling water. Digestion is maceration where gentle heat is used in the process of extraction. This method is used where moderately elevated heat is required. Decoction is when the crude drug is boiled with a specified amount of water over a defined period of time then cooled and strained or filtered. This method works well for water soluble and heat stable constituents. The initial ratio of crude drug to water is fixed for example 1: 4, 1: 16. The volume is then reduced to a quarter of the original volume, then strained or filtered (Handa *et al.*, 2008).

Percolation is used to prepare tinctures and fluid extracts using a percolator. Solid ingredients are well moistened with appropriate menstruum and allowed to stand for 4 hours in a closed container. This is then packed in a percolator and the top closed. Additional menstruum is then added to form a layer at the top and it is allowed to macerate for 2 hours. The outlet of the percolator is opened and it is allowed to drip slowly. More menstruum is added until the percolate measures $\frac{3}{4}$ of the required amount. The marc is pressed and the liquid added to the percolate. Sufficient menstruum is added and the liquid clarified by filtration or decanting after

standing for some time. Hot Continuous Extraction (Soxhlet) is the method where a soxhlet apparatus is used where finely ground drug is placed in a thimble (porous bag). The extracting solvent is put in a flask and heated, its vapours condensing in the condenser. The condensed extractant drips into the thimble extracting by contact. When the level of the liquid in the chamber where the thimble is rises to the siphon the thimble contents are siphoned to the flask. This process is continuous and is complete when a drop of solvent from the siphon tube leaves no residue on evaporation. In this method a large amount of extract can be achieved with limited amount of solvent. It saves on time, energy and financial input (Handa *et al.*, 2008; Ankit *et al.*, 2012; www.motherearthliving.com).

Aqueous –Alcoholic Extraction by Fermentation is where by the crude drug is soaked as a powder or decoction for a specified period of time. Then it generates alcohol *in situ* which facilitates extraction of active principles and acts as a preservative. Fermentation may be carried out in earthen vessels (not new), wooden vats, porcelain jars or metal vessels. Counter Current Extraction (CCE) is whereby wet raw material is pulverised to produce smooth slurry which is moved in one direction within a cylindrical extractor. Then it comes into contact with the solvent. The further the material moves the more concentrated is the extract hence it is important to optimise the quantity of the solvent and their flow rate. This process is efficient and requires less time without any risk of high temperatures. The concentrated extract gets out from one end and the marc which is free from the solvent on the other end (Handa *et al.*, 2008; agritech.tnau.ac.in; www.philadelphia.edu.jo).

Ultra Sound Extraction (Sonication) is a method which involves the use of ultra sound with frequencies of between 20 kHz and 2000 kHz. This increases permeability of the cell wall and it

increases cavitation. This process is costly and also forms free radicals of active ingredients thereby changing the drug molecule. This is caused by high ultrasound energy which damages the phytochemical. Supercritical Fluid Extraction (SFE) is a process that enhances increased extraction and reduced organic solvent use. It can use either carbon dioxide or Argon as a solvent. The latter is preferred due to its being inert. The method finds application in the extraction of pesticides, environmental samples, foods and fragrances, essential oils, polymers and natural products. This process has a prohibitive high cost of investment.

The Phytonic process is based on the hydrofluorocarbon-134a as a solvent. It is a new process which can be used to get high quality natural fragrance oils, flavours and biological extracts which can be used directly without further chemical or physical treatment. The solvent is poor and can be combined with other products to give specific endpoints. This process is carried out in ambient temperatures and neutral PH. It is environmental friendly and self sustaining until a complete cycle has been completed. The solvents are completely recycled within the system (Handa *et al.*, 2008; Ankit et al., 2012; agritech.tnau.ac.in; www.philadelphia.edu.jo).

2.7.2 Phytochemical constituents of phytomedicines

Plants have almost limitless ability to synthesise phytochemicals mainly secondary metabolites. About 12,000 of these have been isolated which is a number less than 10% of the total. These molecules serve as the plant defence mechanism against predation by micro organisms, insects and herbivores. Some of them produce plant odour like terpenoids, others pigmentation like tannins and quinines, while others produce flavor like capsaicin. More importantly several of these molecules possess medicinal properties (Peteros and Mylene, 2010).

Some phytochemicals with physiological properties may be elements rather than complex organic molecules. Abundant in many fruits and vegetables, selenium, for example, is involved with major metabolic pathways, including thyroid hormone metabolism and immune function (Brown and Arthur, 2001). Particularly, it is an essential nutrient and cofactor for the enzymatic synthesis of glutathione, an endogenous antioxidant (Papp *et al.*, 2007)

2.8 Classification of Organic Phytochemical

2.8.1 Terpenoids

A terpene unit is a hydrocarbon chain made of 10 Carbon atoms and 16 Hydrogen atoms. It is the basis for classification for a variety of organic molecules, many of which are volatile. The classes are based on the number of terpene units in each molecule including: monoterpenoids, diterpenoids triterpenoids, sesquiterpenoids (Harbone, 1984, 1998)

2.8.2 Alkaloids

These organic compounds are some of the most biologically active molecules that plants produce. At their simplest, they consist of a carbon ring into which a Nitrogen (N) atom is inserted. Some examples are Nicotine (Tobacco), Lobeline (Lobelia), Morphine and Codeine (Opium poppy), Atropine (Belladonna), Cocaine (Coca), Caffeine (Coffee), Hydrastine and Berberine (Goldenseal), Ephedrine (Ephedra), Mescaline (Peyote), Quinine (Cinchona spp.), Taxol (Yew). The substances are very intense, heroic medicines that can be quite toxic in high doses (Harbone, 1984, 1998)

2.8.3 Iridoids

These are a subclass of altered monoterpenoids. They are also called lactones. They generally have a bitter taste and are often responsible for the effect of 'herbal bitters'. Some examples are

Kavalactones (from Kava-Kava), Nepetalactone (from Catnip), and the Valepotriates (from Valerian). In general, most iridoids/lactones are sedative, laxative, bitter and salilagogue (Harbone, 1984, 1998).

2.8.4 Saponins

These compounds are soap-like and are fairly well soluble in water. They can help dissolve other, more oily, compounds as well because of their nature. They can be found in many plants, including lots of food plant families especially the pea family, and notably in ginseng and licorice with glycirrhizin. If an infusion, decoction or tincture is shaken and a stable foam remains on the surface, saponins are probably present. They have a variety of actions, some due to their 'soapiness' (although they are mostly broken down in the stomach), others due to the effect of their metabolites. Saponins can be thought of as being crucial in the adaptogen class, helping to stimulate our body/minds into better tone. As such, they are adaptogenic, hepatoprotective, and immune modulators, anti-bacterial, expectorant, anti-inflammatory, diuretic and alterative (Harbone, 1984, 1998)

2.8.5 Steroidal saponins

This is a sub-class of the saponins and the compounds have similar activities, bordering on the phytosterols. They are found in plants such as Astragalus, Black Cohosh, Ginseng (Ginsenosides), and Wild Yam (Diosgenin) (Harborne, 1984, 1998).

2.8.6 Cardioglycosides

These are a specific sub-class of steroidal saponins that have a tonic effect on the heart, however only in small doses. In larger doses they are quite toxic. David Hoffman tells how butterflies, who in general are immune to these glycosides, store them in their tissues to dissuade birds (who

can die from them) from eating them. Convallotoxin, from lily of the valley, and digitalis, from foxglove (of Dr. Withering fame) are two prime examples. They are cardio-tonic in tiny doses, stimulating the heart to work much more efficiently (Harbone, 1984, 1998).

2.8.7 Phytosterols

Different phytosterols have been isolated from Red Clover and other herbs and are being termed as 'estrogenic' replacements for synthetic hormones. Their presence may or may not be responsible for the anti-hot-flash activity of some herbs. Some phytosterols include cholesterol and testosterone (mostly found in animals, although also in some plants), estradiol (found in members of the pea family), stigmasterol from soybeans. They are fairly water-soluble, and in general, they possess anti-tumor and anti-inflammatory activity (Harborne, 1984, 1998).

2.8.8 Resins

These are sticky, oily substances that are often exuded from tree barks. Myrrh, Pine pitch, Frankincense, and Dragon's blood are some examples. Other plants possess some amount of resin in their tissues the most striking example is Grindelia, a sticky plant whose flowers secrete an aromatic white resin. Propolis is a collection of various resins collected by bees to protect their hives; they tend to have an antiseptic, anti-bacterial, expectorant, nervine and rubifacient activity (Harbone, 1984, 1998).

2.8.9 Phenols

These comprises molecules with both a hydroxy (-OH) group and an aromatic resonant ring (C6 six carbons). There is a variety of different structures. From the basic compound, different atoms and functional groups can be added, or the structure itself can be repeated multiple times. Generally, phenolics are fairly water-soluble, and exist in every plant in one way or another. The

simple phenols include such compounds as Salicin (in Willow and Meadowsweet), Arbutin (in Uva-Ursi), and Vanillin (from Vanilla). Phenols have antiseptic, anti-inflammatory, analgesic (anodyne), blood-thinning, and rubifacient externally as major activities (Harbone, 1984, 1998).

2.8.10 Additional phenolic compounds (Polyphenols).

2.8.10.1 Phenolic acids

These compounds are simple variations on phenols with the addition of a carboxylic group (-COOH) that gives them a slightly acidic pH and increases their solubility. A prime example is salicylic acid (aspirin), derived from modifying Salicin. These compounds have anti-inflammatory and anti-pyretic activity (Harbone, 1984, 1998).

2.8.10.2 Coumarins

To form this group there is additional rings to the basic phenol structure. In this class, there is the basic original C6 aromatic ring to which is attached another ring with 3 Carbons. In Coumarin itself (from Turmeric), the additional slot on the adjacent ring is taken up by oxygen (O). These compounds have anti-inflammatory and antiseptic activity, and although they can possess a variety of other actions depending on how different they are from the basic structure, these two will always be present (Harbone, 1984, 1998).

2.8.10.3 Quinones

These molecules can get quite large and complex. Simple Anthraquinones are derived from Anthracene, a three-ring structure, (C6 – C2 – C6). Sennoside and Rhein (found in Senna, and Rhubarb to some extent) are compounds with anthraquinones and are laxative and can be quite strong. They seriously stimulate peristalsis, and can be habit-forming. They are also alterative because of their function in tissue elimination. There are many other quinones as well, with the

napthaquinones being a two-ring structure (C6 – C4), and much more complex quinones involving stacked tiers of multiple carbon rings, like Hypericin (from St. John's Wort). These compounds have antiviral, antiseptic and anti-bacterial activity (Harbone, 1984, 1998).

2.8.10.4 Flavonoids

Flavonoids, basic structure is made of two rings, connected by a three-carbon (C3) chain. These compounds are responsible for pigmentation in plants and for many medicinal effects. Primarily, they have an antioxidant effect, but usually possess a certain degree of antiseptic, immunomodulating, and circulatory stimulant effect. Some sub-classes of this huge family include the anthocyanidins and oligomeric pro-anthocyanidins (OPCs) (Pine bark extract, Blueberries), catechins (Green Tea), flavonols (Quercetin), isoflavones (Red Clover, and Soy). There is research going on around these compounds for fighting tumors, improving memory and circulation, fighting allergies, protecting the liver (Sylimarin is a bioflavonoid), aiding in hormone regulation, helping the nervous system, among others (Harborne, 1984, 1998).

2.8.10.5 Lignans

These are polymers of phenolic compounds, meaning they consist of simple phenols and/or flavonoids linked together in long, complex chains. They are found in woody tissues of plants. They have adaptogenic, antioxidant, anti-tumor and antiviral activities, and are partly responsible for the medicinal effect of Chaparral, for example (Harborne, 1984, 1998).

2.8.11 Tannins

Very often astringency in plants will be due to the presence of these compounds. White Oak is a great example of an herb rich in tannins. There is some cross-over between these compounds and the proanthocyanidins of the flavonoid class. The primary chemical property is that they bind

proteins, making them difficult to absorb by reducing their solubility in water. They are probably chemical protectors for the plants themselves, ensuring the integrity of cell walls and internal tissues. They are astringent, anti-tumor, and help with diarrhea (Harborne, 1984, 1998).

2.8.12 Carbohydrates

These are simple sugars and also include more complex polysaccharides and starches. Their function, especially of the monosaccharides, is primarily nutritive and as a source of energy for the body. The more complex sugars can have interesting adaptogenic and immuno-modulating power (such as, for example, the polysaccharide fraction of Echinacea), and the starches often contribute to plant structure, along with the lignans. Combining with amino acids, they form glucosaminoglycans, of which Glucosamine is the most famous. They also often combine with phenolic compounds and become known as glycosides, such as flavonoids (Harbone, 1984, 1998).

2.8.13 Mucilages

These are a specific class of polysaccharides that form soothing, healing, often slimy solutions in water. Marshmallow root, Comfrey, Corn silk and Slippery Elm are good examples of this subclass, and all of them have strong demulcent action (Harbone, 1984, 1998).

2.8.14 Lipids

These are naturally occurring fats and oils. The most important class of lipids is the essential fatty acids (EFA's), of which Linoleic acid is the best known and is found in Flax, Evening Primrose, Borage, and Black Currant seeds. These possess anti-cholesterol, anti-inflammatory and hormone-regulating activities. They are not very water soluble, so administration occurs by

ingesting the crushed seeds or an oil extract, or by emulsion with a saponin (Harborne, 1984, 1998).

2.8.15 Proteins

This is a large family of compounds, providing the building blocks for cell membranes, musculature, hemoglobin in animals and chlorophyll in plants, DNA and RNA in cell nuclei and enzymes that aid in metabolism. They are essential for life to exist because all body processes are mediated by proteins. They all come from a single dietary source: amino acids. They have a huge variety of structures, but always possess an amine group (-NH₂). They can combine with other molecules, forming amides (Harbone, 1984, 1998).

2.9 Literature of some of the plants studied

2.9.1 *Clerodendrum myricoides* (Hoechst) Vatke

The genus *Clerodendrum* L. (Family: Lamiaceae) is very widely distributed in tropical and subtropical regions of the world. More than five hundred species of the genus are identified till now, which includes small trees, shrubs and herbs. Ethno-medical importance of various species of *Clerodendrum* genus has been reported in various indigenous systems of medicines and as folk medicines. The genus is being used as medicines specifically in Indian, Chinese, Thai, Korean, Japanese systems of medicine for the treatment of various life-threatening diseases such as syphilis, typhoid, cancer, jaundice and hypertension. Few species of the genus like *Clerodendrum inerme*, *C. thomsonae*, *C. indicum*, and *C. speciosum* are ornamental and being cultivated for aesthetic purposes. The powder/paste form and the various extracts of root, stem and leaves are reported to be used as medicine for the treatment of asthma, pyreticosis, cataract, malaria, and diseases of blood, skin and lung. To prove these ethno-medical claims, some of

these species are being extensively studied for their biological activities using various animal models. Along with biological studies, isolation and identification studies of chemical constituents and its correlation with the biological activities of the genus has also been studied. The major chemical components reported from the genus are phenolics, steroids, di- and triterpenes, flavonoids, volatile oils, among others (Shrivastava and Patel, 2007). Figure 1 is an aerial photograph of *C. myricoides*.



Figure 1: Photograph of *clerodendrum myricoides* (Hoechst) Vatke from Samburu County

2.9.2 *Acacia tortilis* (Hayne)

The Genus has a global distribution but it is native to much of Africa and the Middle East. The parts used include the pods, bark and the wood. It is usually prepared as a decoction, infusion and dust and taken orally. It is a medium umbrella-shaped tree 4-15 m tall, often with several trunks, reduced to a small wiry shrub less than 1 m tall under extremely arid condition. Leaves are up to 2.5 cm long. Flowers are white, aromatic, and in small clusters. Pods are flat, glabrose and coiled into a spring-like array. Flowering occurs in May-June and fruits occur in July, but ripening is from November to February. Its constituents include proteins (19%), fats (2.5%), carbohydrates (46.5%), minerals (5.1%) and crude fibre (20.1%) which is found in the pods while the leaves contain flavonoid glycosides and tannins (www.fao.org). Figure 2 is a photograph of *Acacia tortilis*.



Figure 2 Photograph of *Acacia tortilis* (Hayne) from Samburu County.

2.9.3 *Myrsine africana* L.

Myrsine africana, belongs to the family *Myrsinaceae*, a large family of about 33 genera and nearly 1000 species, widespread mainly in the tropical and subtropical regions (Choudhury, *et al.*, 2007). Traditionally, the plant is used as fragrance in tea, spices, carminative, appetizer and flavoring agent. Its fruits are edible and locally used as an anthelmintic (Zabta *et al.*, 2003; Kokwaro, 1993; Beentje, 1994; Desta, 1995) and for the treatment of diarrhea, rheumatism, toothache, pulmonary tuberculosis and relieving hemorrhage (Zhong, 1985). It is active against the tapeworm (Choudhury *et al.*, 2007). Figure 3 is a photograph of the plant *Myrsine africana* together with one of the reknown herbalists within Samburu community.

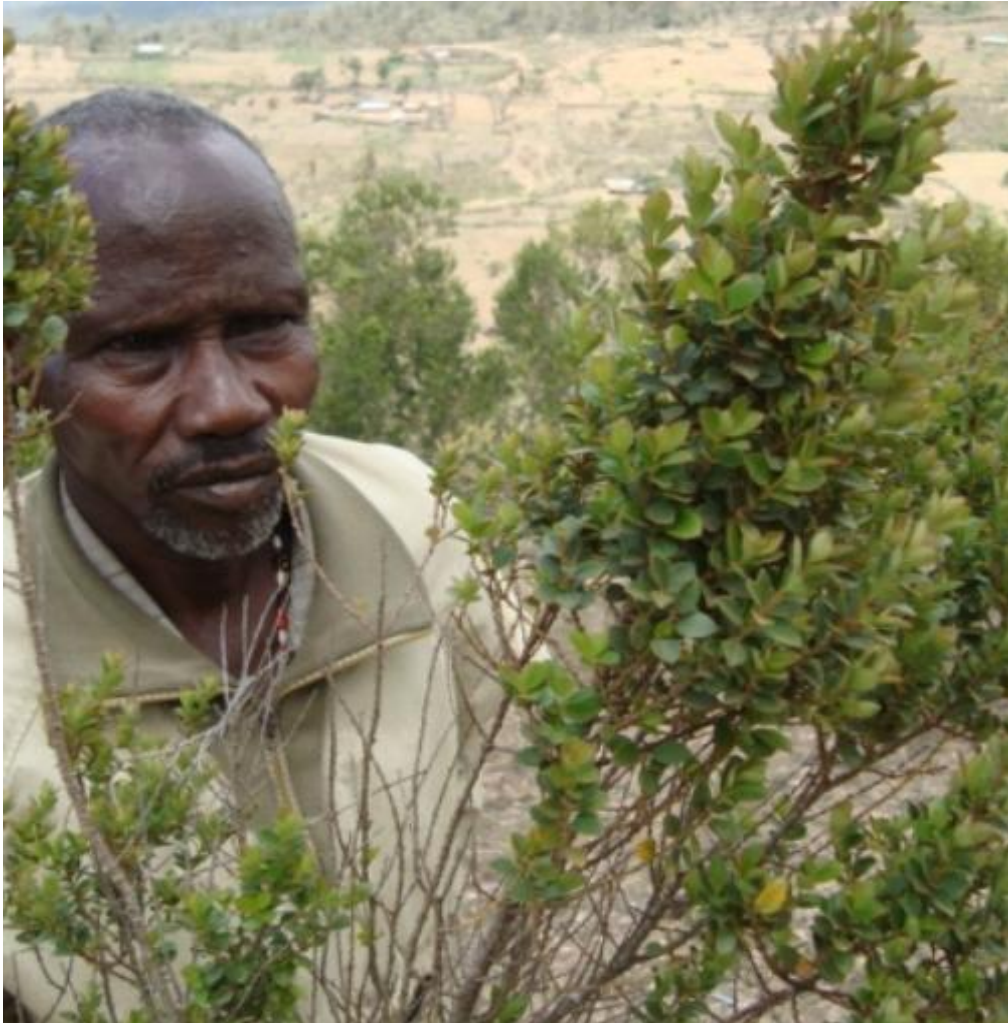

Figure 3 Photograph of *Myrsine africana* L. and one of the oldest and reknown herbalists within the Samburu Community Kenya

2.9.4 *Carissa edulis* (Vahl) with ripened fruit.

As it has been reported by (Bekele *et al.*, 1993, Beentje, 1994, Burkil, 1994) this plant belongs to the family *Apocynaceae* and is a spiny, much branched, small tree, shrub or scrambler, up to 5 m in height. The flowers are white tinged with purple, red or pink and sweetly scented. The fruits are ovoid to almost spherical and red-black, ripening to purplish black. The name *Carissa* is probably derived from the Sanskrit 'corissa', a name for one of the Indian species of the genus. The specific name, *edulis*, means edible. *C. edulis* is found in Arabia, Africa, Asia and Indo-China. It can be found at an Altitude of 1 000-2 000 m above sea level and tolerates most soils including black cotton.

The fruits are sweet and pleasant to eat, while the roots are put into water gourds to impart an agreeable taste and are added to soups and stews for the same reason. Goats and camels in the dry areas browse on *C. edulis* and the species is a source of excellent firewood. In Kenya, a piece of the root is fixed into a hut roof as a snake repellent. The roots contain an active ingredient, carissin that may prove useful in the treatment of cancer while the twigs contain quebrachytol and cardioglycosides that are useful as anthelmintic against tapeworm. The boiled leaves are applied as poultice to relieve toothache. The root bark is mixed with spices and used as an enema for lumbago and other pains and root scrapings are used for glandular inflammation; ground-up roots are used as a remedy for venereal diseases, to restore virility, to treat gastric ulcers, cause abortion, and as an expectorant. An infusion of roots along with other medicinal plants is used for treating chest pains, and a root decoction is also used for treating malaria. *C. edulis* is an attractive plant that is suitable for planting in amenity areas and the abundant branching habit and the presence of spines make the plant suitable for planting as a protective hedge. Figure 4 is a photograph of *Carissa edulis*



Figure 4 Photodgraph of *Carissa edulis* (Vahl)

2.9.5 *Rhamnus Prinoides* (L'Herit)

According to Kokwaro, (1993), Beentje, (1994), Hong *et al.*, (1996), among others *Rhamnus prinoides* L' Herit belongs to the family *Rhamnaceae* and is commonly known as dog wood or shiny leaf. The plant is a shrub or a small dense thick bushy tree that may reach up to 9m in height. The plant is common at medium to high altitude, along water courses, in riverine forest and at the margins of evergreen forests and frequently among rocks. It can be found in South African countries, tropical Africa, Kenya and Ethiopia. The plant thrives in moist humus soils.

The plant can be used as food as the fruits are edible. A decoction of the tree is taken as a blood purifier, treats pneumonia, gonorrhoea, rheumatism and stomach ache. The leaves are applied as liniment to simple sprains. Further the tree can be cultivated to control soil erosion, it can be used as a hedge to act as a wind breaker and around fish ponds to protect and shade the fish. The plant can be used effectively as an ornamental plant. Figure 5 is a photograph of *Rhamnus prinoides*.



Figure 5 Photograph of *Rhamnus prinoides* (L'Herit)

2.9.6 *Rhamnus staddo* A. Rich

Rhamnus staddo belongs to the family *Rhamnaceae* and it has been traditionally used in East Africa to treat malaria, venereal diseases and anaplasmosis (<https://www.thieme-connect.com/ejournals/abstract>, Bussman *et al.*, 2006, Kiringe, 2006). Figure 6 is a photograph of *Rhamnus staddo*



Figure 6 Photograph of *Rhamnus staddo* A. Rich

2.9.7 *Sansevieria ehrenbergii* Bach

Sansevieria ehrenbergii is commonly known as East African Wild sisal. It grows well in Northern Africa, Eastern Africa and Saudi Arabia. It occurs widely along the Olduvai Gorge in Northern Tanzania. This plant is commonly used by the Maasai community as a natural wound bandage (wikipedia). Figure 7 is a photograph of *Sansevivierria ehrenbergii*.



Figure 7 Photograph of *Sansevieria ehrenbergii* Bach

2.10 The Samburu Culture

The Samburu people are Nilotes who are closely related to the Maasai. They are semi-nomadic pastoralists who keep cattle, sheep, goats and camels. They speak the Samburu language which has its origin from the Maa language spoken by the Maasai. (www.magicalkenya.com). The Samburu people live in settlements called Manyattas which are usually prepared by the women folk. The Manyattas usually host three to five families. The Samburu practice polygamy where one man may have several wives. This practice starts from an early age where the morans (warriors) are allowed to bead girls only for purposes of entertainment. In case the girl conceives she is sent to a midwife to procure an abortion. This beading is repeated till the girl is ready for marriage (Straight, 2005).

The Samburu people adorn themselves with color as seen in their traditional way of dressing. This manner of dress describes them well in relation to their name which translated means butterfly. The women are good at weaving the beads which are won by both gender. The women from an early age are given beads by their admirers the morans and by the age of fifteen and sixteen the girl should have enough beads to support the chin. Then she will have reached an age for marriage. The beads are given frequently and generously by their admirers and the necklaces soon merge to form a collar (Straight, 2005)

CHAPTER THREE

ETHNOPHARMACOLOGICAL PRACTICES USED IN MANAGEMENT OF SEXUALLY TRANSMITTED INFECTIONS IN SAMBURU COUNTY, KENYA

3.1 INTRODUCTION.

Sexually transmitted diseases occur worldwide. The prevalence of Sexually Transmitted Infections (STIs) worldwide is high (8.5%), despite diagnostic and therapeutic advances that can manage most of these infections (Mary-Ann and Ann Barbara, 2006). This is compounded by the development and spread of drug-resistant micro-organisms like penicillin-resistant gonococci. An estimated 340 million new cases of STIs mainly syphilis, gonorrhoea, chlamydia and trichomoniasis occur throughout the world annually with Sub-Saharan Africa leading with 11 to 35% of all new STIs (WHO, 1999 a, Avert.org. <http://www.avert.org/stdstatisticsworldwide>). This is probably due to Lack of access to resources for health care and treatment. An estimated 1 million people in Africa are being infected by STI daily especially the youth and women of child bearing age (WHO, 1999 a). Many STIs are asymptomatic and are often inadequately treated or left untreated, leading to Pelvic Inflammatory Disease (PID) and infertility. Untreated Chlamydia and gonorrhoea infections often result in pelvic inflammatory disease (PID), and accounts for 50-80% infertility in Africa (WHO, 2007). Sexually transmitted infections are widespread in Kenya both in urban and rural areas (Peter, 2010). Management of these diseases in rural areas like Samburu County in the Northern part of Kenya is a challenge. In such places, roads for motorized transport are poorly developed. Reaching the pastoralist and nomadic inhabitants with HIV/AIDS and STI services require use of animals for transport. Animals like camels are often used for this purpose. This is compounded by poverty, illiteracy, cultural practices like

polygamy, beading practice and early forced marriages. The Samburu community has to rely on traditional medicine for primary health care because of these problems. In an ethnopharmacological survey conducted in Samburu Kenya STIs were reported to be among the ailments treated by traditional healers using plant remedies (Nanyingi *et al.*, 2008). The study mentioned several plants reportedly used in the management of STIs by Samburu Traditional Healers. Among the plants documented was *Clerodendrum myricoides*. The plant was said to be efficacious but toxic to the patients (Nanyingi, *et al.*, 2008).

Many articles have been published on the traditional knowledge and practices of indigenous people of Samburu, County, Kenya in dealing with many diseases of human and livestock (Njoroge and Bussman, 2006, Kiringe *et al.*, 2006, .Nanyingi *et al.*, 2008) among others. However, a thorough documentation of the traditional use of plants in the management of venereal diseases in Samburu County has not been done. There is no good documentation on the unique and diverse practice on how traditional healers manage venereal diseases. This study was carried out to document the ethnopharmacological practices by the traditional healers of Samburu, Kenya in management of STIs. The study aimed at identifying the plants used, parts of the plant used and methods of preparation and administration of the remedies.

3.2 MATERIALS AND METHOD

3.2.1 Study area

The study was carried out in Samburu County which is located in the dry northern frontier of Kenya. The County covers approximately 21126.5 Km² (Figure 8) and is bordered by other counties including to the West by Baringo, Laikipia to the South, Isiolo to the East, Turkana to the North West and Marsabit to the North. It is characterized by high level plateaus, hills and the Great Rift Valley with an altitude of up to 2000 m above sea level. The area has a bimodal

rainfall distribution pattern which runs from April to May (long rains) and July to September for short rains. The dry season then extends from January to March. The mean annual rainfall is 500 mm and the mean annual temperature is 29°C. The Samburu people are the dominant indigenous ethnic group (80%) but Turkana, Kikuyu, Meru, Somali and Maasai people (20%) have also settled in the area. Pastoralism is the major economic activity of the local people. The District is sparsely populated and has a population of approximately 156,125 inhabitants. These rural communities are almost totally dependent on forests and savannah as source of traditional medicine for their own health and livestock care (Central bureau of statistics, 1999). The pastoral livelihood exposes this community to complete lack of formal infrastructure hence they rely on the natural resources. The area is harsh and difficult to survive during the dry spell.

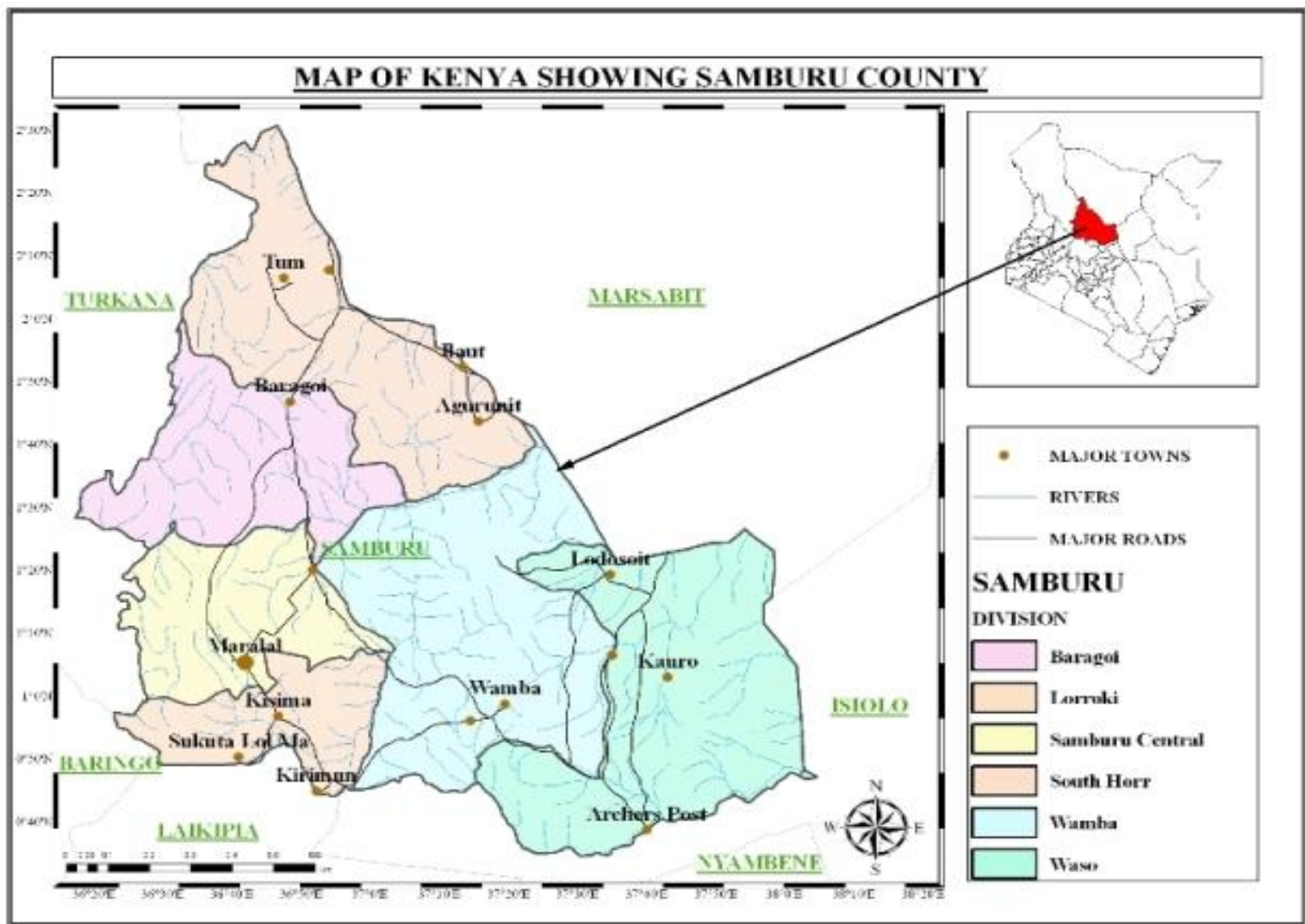

Figure 8: The map of Kenya showing the location of Samburu County and its administrative boundaries

3.2.2 Ethnobotanical survey of indigenous knowledge and practices of Samburu people in management of STIs

Preliminary data on social, economic and geographical characteristics of the study area was collected. The study employed participatory epidemiological approaches including interviews, questionnaires, focused group discussion and transect walks involving local community and Traditional Herbal Medicine Practitioners (THMP), all of which culminated in an ethnobotanical workshop. A validated semi-structured questionnaire (Appendix 3) was used to obtain information on indigenous knowledge on ethnodagnostic and treatment of sexually transmitted infections (STIs) in Samburu County, Kenya. The interviews were recorded in specifically designed forms detailing interviewees' personal information, medicinal plant knowledge and utilization as well as the availability and status of the target plants.

An inaugural stakeholder's workshop involving Samburu Integrated Resource and Aids Network (SIRAN) a community based organization, researchers from the University of Nairobi and Samburu traditional healers was held in Maralal. Twenty nine herbalists from Maralal, Kirisia, Malaso, Baragoi, Loroki, Wamba and Nyiro Divisions of Maralal County were involved in the study. Leading questions and technical terms were avoided when asking the questions. The major questions addressed the medicinal plant usage in the management of STIs. The participants were assured that their responses shall remain confidential and would only be used for research purposes. Each informant was interviewed independently and information on the following data was obtained; methods of diagnosis of STIs, names of plant and part used, method of preparation, dosage and means of administration, antidotes used in case of overdose, storage as well as plant status and habitat. Both formal and informal consents were obtained from the herbalists prior to the interviewing session.

3.2.3 Collection and identification of medicinal plants used in management of STIs

Plant samples were collected depending on the part used from highlands, escarpments and lowland areas of the vast dry land with the assistance of the Samburu herbalists. These included the leaves roots stem fruits and seeds. Only the medicinal plants reported by the herbalists as useful in the treatment of STIs were collected. Sixteen medicinal plants were identified in situ by the herbalists and plant specimens collected for botanical identification. The specimens were identified by a botanist at the University of Nairobi, Department of Land Resource Management and Agriculture Technology (LARMAT) where voucher specimens were allocated a specific number and the voucher specimen deposited (Appendix 5).

3.2.4 Data Analysis

The information collected was normalized and summarized into meaningful units prior to calculating descriptive statistics.

3.3 RESULTS

3.3.1 The Samburu ethnodagnostic skills

The specific STIs managed were not confirmed using laboratory diagnosis but were arrived at using the associated clinical signs as perceived by the traditional Samburu medicinal healers who have accumulated knowledge to identify various ailments using clinical symptoms. Herbalists associated STIs such as gonorrhoea with backache (14%), pus in urine (52%), blood in urine (10%), urine blockage (14%), wounds in the mouth and eyes (7%), painful urination (28%), swollen genitals (17%), abdominal pain (10%), fever (7%), headache (3%), poor weight gain (3%) and yellow urine (3%).

3.3.2 Biodata of Samburu Traditional Healers.

Twenty nine consented THMPs participated in the workshop (59% males and 41% females). The majority (42%) of the respondents were mature adults aged between 48 and 57 years. Thirty four percent (34%) of the herbalists were older than 57yrs. Majority of them (62%) had practiced herbal medicine in the area for over 10 years. Fifty percent (50%) of respondents had no formal education while the other 50% had some formal education with the highest level of education being secondary school (20%) and primary school education (20%). All the herbalists interviewed claimed to have used herbal remedies to treat venereal diseases.

Most of the THMPs interviewed had gained skills either from their parents (45%) or they were trained by other herbalist (65%). Some of the members belonged to various organizations such as Samburu Integrated Resource Aid Network (SIRAN), Samburu Livestock Traders Association, Maendeleo Ya Wanawake, a women group, Samburu Traditional Healers Association and Maralal Tree Nursery Association which helped them in one way or another to market their traditional medicine.

3.3.3 Anti STI traditional herbal remedies of Samburu.

Sixteen medicinal plants were reported as useful in samburu area for the treatment of STIs. The plants used belong to 15 families distributed in 16 genera as detailed in Table 3.1(Appendix 5). The parts of the plants that are commonly used are the roots (58%), followed by the stem bark (17%), the leaves (10%) branch bark, fruits, seeds and shoots (3%) as shown in Figure 9. The plants are usually used after drying either as a powder or the unground part. Most of the medicinal plants were abundant apart from the dry season when the plants would only be available in the high land area. They however became scarce in the lowland and the escarpment especially during the dry season.

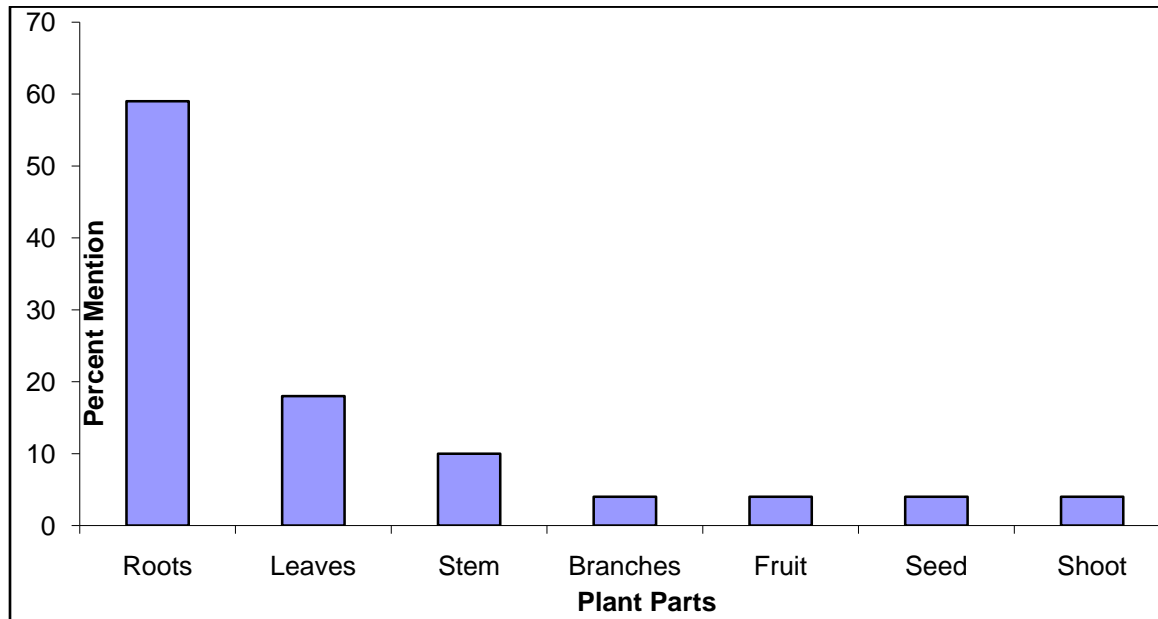

Figure 9: Percent mention of the plant parts used in the management of sexually transmitted diseases by Samburu traditional healers

Clerodendrum myricoides ranked first (93%) among the medicinal plants used in the management of STIs (Figure 10). Fifty two percent (52%) of the respondents reported that this plant is used alone to manage STIs while others reported that it is used in combination with several other plants (Figure 11). Those who preferred mixing several plants reported that this reduced the possibility of toxicity and the bitter taste of the product.

The remedy is usually formulated as a decoction for oral administration. However, in chronic and recurrent cases of STIs, *Clerodendrum myricoides* decoction is administered per rectum (3%). However, fresh plant of *Clerodendrum myricoides* was reported to be toxic when used alone. Thus, for oral dosing, the decoctions and concoctions are usually mixed with excipients like soup, milk, fat, oil, soap and even blood to reduce toxicity and mask the bitter taste of the product. The decoctions are given once, twice or thrice a day for one up to seven days or until recovery. Moreover, according to the respondents (69%); the plant is used cautiously since toxicity may occur if the dosage is exceeded. The adverse symptoms of overdose reported include stomachache (17%), fainting (12%), vomiting (10%), diarrhea (2%), headache (2%), rectal prolapse (2%), inappetence (2%) and weakness (5%) However milk, fat and even blood were reported to be used to ameliorate the adverse effects.

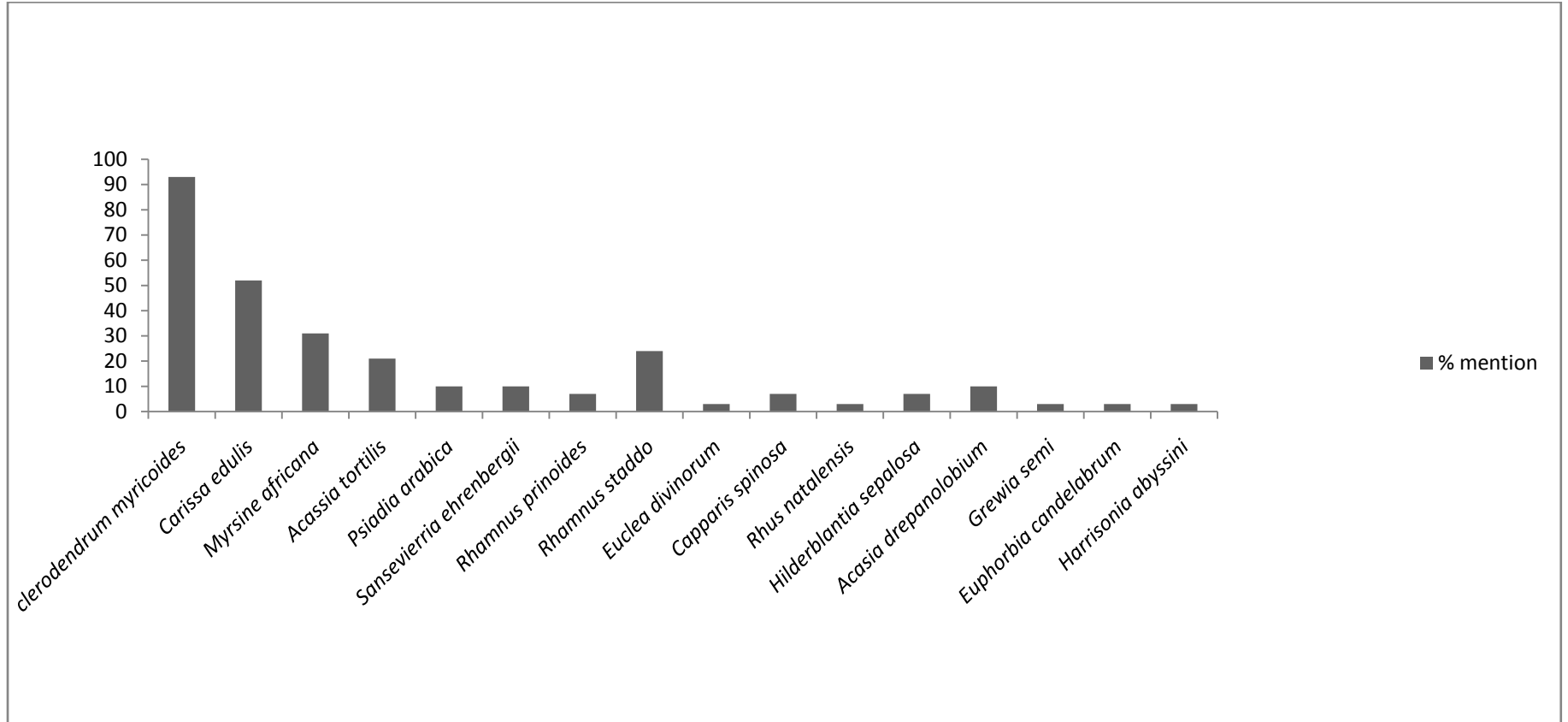

Figure 10: The Percent mention of the plants used to manage sexually transmitted diseases by the Samburu traditional healers

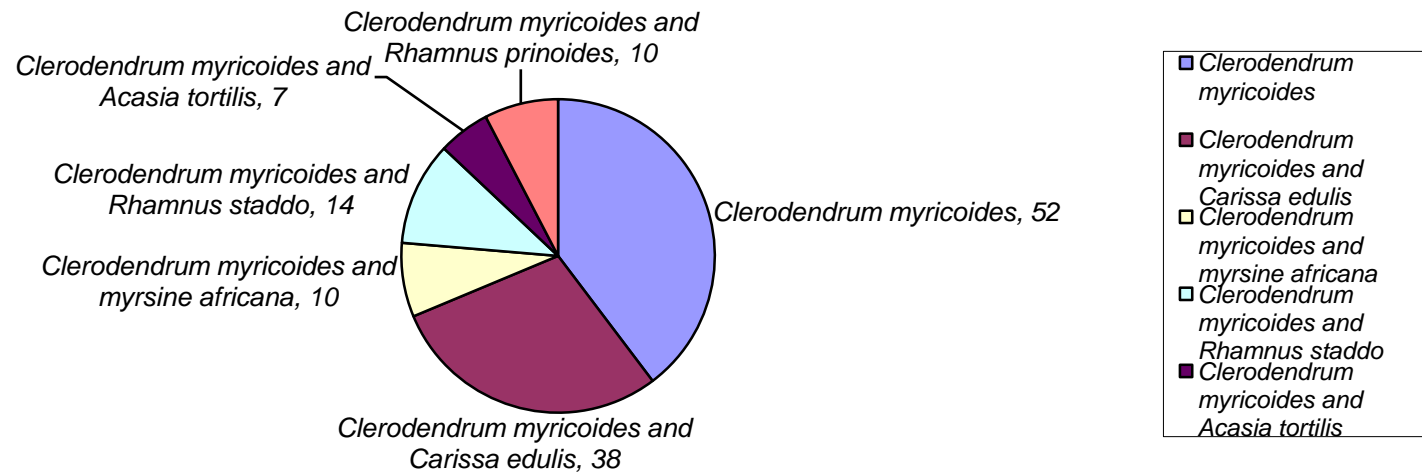

Figure 11: The percent mention of how *Clerodendrum myricoides* is mixed with other plants by the traditional healers to treat sexually transmitted infections

3.4 Discussion

Traditional medicine remains the most affordable and easily accessible source of treatment in the primary healthcare systems of poor communities (Yinegar *et al.*, 2007). This is not different of the Samburu community in Kenya as the respondents cited in this study reported several medicinal plants that they use traditionally in management of STIs. The major health problems experienced by Samburu, as with most rural African populations, are infectious diseases including venereal diseases, malaria, pneumonia, gastroenteritis, diarrhea, measles, and whooping cough (Bussman, 2006). Some of the clinical signs reported for STI included pus in urine, urine blockage, blood in urine and even painful urination. Patients presenting with these clinical signs to traditional healers were administered to herbal remedies preferentially *Clerodendrum myricoides* alone or in combination with other plants. *Clerodendrum myricoides* (Hoechst Vatke) has also been reported to possess antibacterial and antifungal activity in a study done in Ethiopia (Abebe, 1998). The roots of this plant squeezed fresh and the juice mixed with milk and then administered orally in very small amounts are reported to cure Rissaa (Yinegar *et al.*, 2008). However, among the Samburu the plant roots are taken when in powder form and not while wet to avoid toxicity.

The Samburu have reported that use of *Clerodendrum myricoides* alone is toxic. This is in contrast to Yinegar report, (Yinegar *et al.*, 2008) where no toxicity was reported. This may be as a result of the different parts of plants used by the different communities. The samburu use the roots while the study from Ethiopia reported the use of plant leaves (Yinegar *et al.*, 2008).

Carrisa edulis (Forsk) Vahl was also used for treatment of STI by the Samburu community although less frequently than *Clerodendrum myricoides*. It was also the main plant of choice for

mixing with *C. myricoides*. This plant has also been used for treatment of STI before (Burkill, 1995, Bussman *et al.*, 2006).). The other plants mentioned in the treatment of STI are *Rhamnus staddo* A. Rich, and *Rhamnus prinoides* L'Herit, *Sansevieria ehrenbergii* Bach. *R. staddo* and *R. prinoides* which have also previously been cited in literature as medicinal remedies for STIs among the Samburu of Mt Nyiro, (Bussman *et al.*, and 2006) and the Masaai of Kajiado, Kenya (Kiringe, 2006). *Sansevieria ehrenbergii* Bach has been referred in other studies as a treatment for gonorrhoea (Ichikawa, 1998) and also has strong antifungal activity (Mohammed *et al.*, 2007) *Psiadia Arabica* Jabb and Spach was mentioned as a remedy for STIs in our study. It contains flavonoids and kaulene as the bioactive compounds (Keriko *et al.*, 1995, Midiwo *et al.*, 2002). *Myrsine africana* L. was also cited among the remedies for STIs and has been reported as having antifertility, analgesic, anti-inflammatory, antibacterial, antitumor activities. Additionally it has free radical scavenging compounds (Sileshi *et al.*, 2007). Five plants including *Capparis spinosa*, *Acacia drepanolobrum*, *Hilderbranta sepalosa*, *Myrsine africana* L., and *Psiadia Arabica* Jabb and Spach were mentioned for the first time as useful in treatment of STIs.

In conclusion, this study provides important data that forms a basis to validate the efficacy and safety of plants used in the management of STIs by Samburu people. Community engagement in problem based research for development will usually stimulate market driven product development research that can enhance livelihoods of communities and motivate conservation of medicinal plants and the associated indigenous knowledge. This fact has been taken positively by the Samburu herbalists in collaboration with the Ministry of Forestry, Culture and National Heritage and Non governmental organization (SIRAN) to start tree nurseries at Maralal Town Samburu County. Furthermore, the results of this survey show that several plants are used in STIs management in Samburu. Although the plants are generally safe, some may cause serious

toxic effects for example *Clerodendrum myricoides*. *Clerodendrum myricoides* (Hoechst Vatke) is considered toxic based on the results of the current study and therefore safety standards need to be instituted through laboratory techniques so that the traditional healers may safely and efficaciously administer the herbal remedies. Notably the main parts of the plants used are the roots, which pose a danger to the sustainability of the medicinal remedies. It is therefore important to institute concerted measures so as to be able to conserve this important flora. The respondents reported that they have started a tree nursery which would help in reforestation of the important species that are being threatened by climate change and over use

CHAPTER FOUR

PRELIMINARY PHYTOCHEMICAL SCREENING OF THE CRUDE EXTRACTS OF *CLERODENDRUM MYRICOIDES* FROM SAMBURU COUNTY KENYA

4.1 INTRODUCTION

Phytochemicals found in medicinal plants are used in pharmaceutical, cosmetic, agricultural and food industry. The use of the medicinal herbs for curing diseases has been documented in history of all civilizations. Research, has proofed that plants contain active principles which are responsible for the curative action of the herbs. Herbal remedies are used in crude forms such as expressed juice, powder, decoction or infusion among others. Ancient healers, who developed formulations based on medicinal herbs, were probably not aware of the chemical composition of the herbs. But the advance they made despite non-availability of scientific procedures is astonishing. Scientific research has proved the utility of these time tested remedies (Amrit, 2005). The medicinal value of these plants lies in some chemical substances that produce a definite physiological action on the human body. The most important of these bioactive constituents of plants are alkaloids, tannins, flavonoids and phenolic components (Hill, 1952).

The genus *Clerodendrum* has been cited in many indigenous systems of health care for the treatment of a variety of disorders. A few species extensively used as folk medicines for years have been investigated for their chemical constituents and biological activity to confirm these traditional claims. The genus is reported to have activities against a wide spectrum of disorders which includes many life-threatening diseases like HIV. Still there are many species of the genus having a potential towards treating many disorders in their unexplored field (Shrivastava and Patel, 2007). *Clerodendrum* is a very large and diverse genus and till now five hundred and eighty species of the genus have been identified and are widely distributed in Asia, Australia,

Africa and America. *Clerodendrum myricoides* is found in Africa (Shrivastava and Patel 2007). Several phytochemicals have been isolated from the genus including steroids, flavonoids, and triterpenes among others while myricoidine has been isolated from *Clerodendrum myricoides* (Shrivastava and Patel, 2007, Bashwira, *et al.*, 2001). There is no documented study of phytochemical screening of *Clerodendrum myricoides* that grows wildly in Samburu County, Kenya. Preliminary phytochemistry was done to get phytochemicals present in the aqueous and methanol crude extracts of *Clerodendrum myricoides* from the Samburu county of Kenya.

4.2 Materials and Methods

4.2.1 Preparation of *Clerodendrum myricoides*

The plant root materials were dried under the shade at room temperature for three weeks. The dried plants were then chopped into small pieces using a sharp knife and were ground into powder using an electric mill. The powder was packed into clean airtight polythene paper bags in portions of 500grammes in a fume cupboard. Further protection was through wearing of face masks.

4.2.2 Preparation of aqueous extract of *Clerodendrum myricoides*

This was carried out according to Erazo, *et al.*, (1997) and Gakuya, (2001). Fourty grams of plant powder was weighed into a conical flask and dissolved in 400mls of distilled water. The mixture was boiled in a hot water bath (100⁰C) for 30 minutes at. The resultant extract was filtered through muslin gauze into clean vials then centrifuged at 4000 revolutions per minute for ten minutes. The supernatant was obtained and put in clean vials. This was then put in a freeze drier for 24 hours then lyophilized in a lyophilizer (Edwards High Vacuum, Model M6B).

4.2.3 Preparation of Methanol /water extract of *Clerodendrum myricoides*.

Fourty grams of powder was weighed into a conical flask and soaked in methanol 70%v/v methanol /water. The mixture was macerated for three days during which time shaking was continually done. The extract was then filtered using whatman no. 1 filter paper. This was then a reduced in a rotary evaporator to dryness under pressure. The resultant residue was put in an oven at 40⁰c for methanol to be reduced completely. The final residue (3.62gms of yield) was obtained and then freeze dried for 24hrs then lyophilized.

4.2.4 Phytochemical screening

Phytochemical Screening of the extracts of *Clerodendrum Myricoides* (Hoechst) Vatke.was carried out according to standard methods of Harborne, (1973, 1984)

Test for alkaloids: Half a gram (0.5g) of plant extract was weighed and stirred in 2 ml of 1% aqueous hydrochloric acid and heated in a boiling water bath for 10 minutes. The mixture was filtered while hot and treated with Dragendorff's reagent. Turbidity or precipitation indicated the presence of alkaloids.

Test for sterols and triterpenes: Half a gram (0.5g) of the extract was defatted with hexane. The residue was then extracted in dichloromethane and the solution dehydrated with magnesium sulphate anhydride. The mixture was treated with 0.5ml acetic anhydride followed by addition of 2 drops of concentrated sulphuric acid. A gradual appearance of green blue colour indicated presence of sterols while colour change from pink to purple indicated the presence of triterpenes.

Test for saponins: Half a gram (0.5g) of the plant extract was dissolved in 5ml of distilled water and shaken for at least five minutes. Frothing that persisted for at least half an hour was used to indicate the presence of saponins.

Test for flavonoids and flavones: Two hundred milligrams (200mg) of the extract was dissolved in 4 ml of 50% methanol. The solution was warmed and metal magnesium added. Five drops of concentrated sulphuric acid were then added. Development of a red colour indicated the presence of flavonoids while orange colour showed presence of flavones.

Test for tannins: Screening for tannins was done using both ferric chloride and lead acetate tests. For the ferric chloride test, half a gram (0.5g) of the extract was dissolved in 2ml of distilled water and filtered. Two drops of ferric chloride were then added to the filtrate. Development of a blue-black precipitate indicated that tannins are present. For the lead acetate test, in a test tube containing about 5mg of extract, a few drops of 1% solution of lead acetate were added and the formation of a yellow or red precipitate indicated the presence of tannins.

Test for cardiac glycosides: The Keller Killian test was applied. A hundred milligrams (100mg) of extract was dissolved in 1ml of glacial acetic acid containing one drop of ferric chloride solution. This was then under-layered with 1 ml of concentrated sulphuric acid. The appearance of a brown ring at the interface of the two layers with the lower acidic layer turning blue green upon standing indicated the presence of cardiac glycosides.

Test for Resins: To 2mg of plant extract, 5 to 10ml of acetic anhydride was added and dissolved by gentle heating. After cooling, 0.5ml of sulphuric acid was added. Bright purple colour produced indicated the presence of resins.

Test for anthraquinones: One gram (1gm) of the extract was dissolved in 70% acetone to a final concentration of 50mg/ml. The Bonträger Test was used to test for anthraquinones. Two milliliters (2 ml) of the test sample was shaken with 4 ml of hexane to defat. The upper lipophilic layer was separated and treated with 4ml of dilute ammonia. The change of the lower layer to violet and then pink indicated the presence of anthraquinones.

Test for Phenols (Ferric Chloride Test): 2ml of distilled water was added to 1mg of plant sample followed by a few drops of 10% aqueous ferric chloride solution. Formation of blue or green colour indicated the presence of phenols

Test for Glycosides: 2mg of plant extract sample was dissolved in 1ml distilled water and then aqueous sodium hydroxide was added. Formation of a yellow colour indicated the presence of glycosides.

4.3 Results

Both aqueous and methanol /water extract showed similar phytochemicals with the exception of methanol/ water that showed the presence of alkaloids. The chemicals included triterpenes saponins, tannins, glycosides, phenols, cardiac glycosides and resins (table 4.1)

Table 4.1 The phytochemicals present in the aqueous and methanol/water extracts of *Clerodendrum myricoides* growing in Samburu County Kenya.

TYPE OF PHYTOCHEMICAL	AQUEOUS EXTRACT	METHANOL/WATER EXTRACT
Alkaloids	-	+
Steroids	-	-
Triterpene	+	+
Saponins	+	+
Tannins	+	+
Flavonoids	-	-
Flavones	-	-
Phenols	+	+
Glycosides	+	+
Cardiac glycosides	+	+
Anthraquinones	-	-
Proteins	-	-
Resins	+	+

+Presence of phytochemical - absence of phytochemical

4.4 Discussion

The phytochemical analysis on the medicinal plant extract showed that similar chemicals except for the alkaloids were present in both aqueous and methanolic extracts. Alkaloids were additionally present in the methanolic extract. The phytochemicals present included; Tannins which are polymeric phenolic substances capable of tanning leather or precipitating gelatin from solution, a property known as astringency (Cowan, 1999). They are used in pharmaceutical preparations because of their astringent action. Tannins are also known to possess general antimicrobial and antioxidant activities (Riviere *et al.*, 2009). At low concentration, tannins can inhibit the growth of microorganisms, and act as an antifungal agent at higher concentration by coagulating the protoplasm of the microorganisms (Adekunle and Ikumapayi, 2006). Tannins may have potential value as cytotoxic and antineoplastic agents (Aguinaldo *et al.*, 2005); but are now being used in the manufacture of plastics, paints, ceramics and water softening agents (Bandarayanake, 2002). Their presence in the extracts under study hence validates the use of the plant as a medicinal remedy by the Samburu community.

Triterpenoids are known for their anti-inflammatory, hepatoprotective, analgesic, antimicrobial, antimycotic, virostatic, immunomodulatory and tonic effects. They are used in the prevention and treatment of hepatitis, parasitic and protozoal infections and for their cytostatic effects. These properties qualify the herbal remedy's use for treatment of Sexually Transmitted Infections and Infertility as reported by the traditional healers. The disadvantage of triterpenoids is the toxicity associated with their hemolytic and cytostatic properties and therefore with ongoing extraction and isolation of natural products there is need to develop their synthetic derivatives with lower toxic and higher therapeutic potential (Dzubak *et al.*, 2006). In the present study the plant has been reported to have toxic effects especially with high dose consumption, and hence is

recommended to be administered only by an experienced traditional healer. Further work is necessary to isolate and identify the active constituents of the plant and elucidate the mechanism of their toxic effects as well as determine the correct dosage that would be safe for future prescriptions.

Cardiac glycosides are known to work by inhibiting the sodium and potassium pump (Na^+ , K^+ , ATPase). This causes an increase in the level of sodium ions and the calcium ion. This inhibition increases the amount of Calcium ions available for contraction of the heart muscle which improves cardiac output and reduces distention of heart; thus are used in the treatment of congestive heart failure and cardiac arrhythmia (Schneider and Wolfling, 2004).

Phenolic phytochemicals were present and have been reported to have antioxidative, antidiabetic, anticarcinogenic, antimicrobial, antimutagenic and anti-inflammatory activity (Arts and Hollman 2005; Scalbert *et al.*, 2005). Such activities would qualify the plant for use as a medicinal remedy.

Saponins which were present have been reported to have mild detergent activity and are used in intracellular histochemistry staining to allow antibody access to intracellular proteins. they are also used in hypercholesterolemia, hyperglycemia, antioxidant, anticancer, anti inflammatory and weight loss, among other factors. They are also known to have anti-fungal properties (De-Lucca *et al.*, 2005) and have been implicated as bioactive antibacterial agents of plants (Mandal *et al.*, 2005, Manjunatha, 2006)

Alkaloids were present in the methanolic extract and are plant metabolites with alkali-like chemical reactivity, and pharmacologic activity. They represent a very diverse group of medically significant compounds such as the opiates. Ergot alkaloids have been used in the treatment of migraine, as uterine contractants and vasoconstrictor agents (Hardman and Limbird,

1996). In addition they exhibit antibiotic activity, antimalarial activity as well as anticancer activity (Robert and Wink, 1998). Their presence in this plant remedy validates its use as the traditional healers claim.

It has been reported that resins are secreted by plants as secondary plant metabolites. The thick and sticky substance apart from being used in paints, are also used in medicine. A variety of trees produce them and each variety has a slight difference in the resins they secrete. Resin in frankincense has been used by the Egyptians in the olden times as eyeliner for its healing properties and recently as a pill for various diseases. Because of its anti-inflammatory properties resins have been used in treatment of arthritis as well as in aroma therapy to release stress and anxiety in Africa (www.arthritistoday.org)

The presence of the various phytochemicals in the crude extracts which have various pharmacological activities could explain why the Samburu community use the plants extensively. The phytochemical composition of the same plant from a geographically different area, the Nandi South District of Kenya was different (Jeruto *et. al.*, 2011). This might be explained by the difference in the soils of the two areas, the time of harvest, the mode of extraction, the mode of storage among other factors (Kokwaro, 1993). This implies that the use of herbal remedies would be affected by geographical variation, a fact that requires further investigation to validate.

CHAPTER FIVE

***IN VITRO* ANTIMICROBIAL ACTIVITY OF SELECTED MEDICINAL PLANTS FROM SAMBURU COUNTY, KENYA**

5.1 INTRODUCTION

Microbial infections are as a result of the invasion of the host body tissue by microbes which include bacteria, viruses, fungi and parasites. Their invasion causes the body to react to them, to their multiplication and to their toxins (Baron, 1996, Signore, 2013). These infections are classified according to the invading micro organisms, the symptoms of disease they present and the duration of infection. They may cause an acute to chronic syndrome of disease (Verlag, 2005). Diagnosis of a disease can be achieved through the symptoms of disease, laboratory tests or the history of the disease (Bruel *et al.*, 2010). Microbial infections can be treated using antibiotics, antiviral, antifungal and antitubercular drugs (WHO, 2010)

As reviewed by Kapil, (2005), antibiotics are important in the treatment of bacterial infections. The discovery of penicillin was followed by great improvement in research related to antibiotics and their use. This led to reduction in morbidity and mortality caused by microbial diseases and especially in the 1940s. Due to the success of antibiotics stringent measures were not followed closely which led to misuse of drugs and antibiotic resistance (Kapil, 2005). This together with non availability, lack of access and high cost of new generation antibiotics have affected negatively earlier achievements of morbidity and mortality; hence the renewed search for new drugs of plant origin as observed by Williams, (2000),

Some selected medicinal plants from Samburu County Kenya were the subject of investigation in this study. *Clerodendrum myricoides* has been reported as having medicinal activity including

treatment of various ailments including venereal diseases, malaria arthritis among others (Kiringe *et al.*, 2006; Nanyingi *et al.*, 2008; Kalyani 1983; Muregi *et al.*, 2006; Jeruto *et al.*, 2008). *Carissa edulis* has been reported as useful in the treatment of diseases such as headaches, chest complaints, rheumatism among others (Ichikawa 1998; Teshome *et al.*, 2004; Kiringe *et al.*, 2006), *Rhamnus staddo* is useful in management of venereal diseases and malaria (Ichikawa, 1998; Kiringe *et al.*, 2006; Muthaura *et al.*, 2007). *Rhamnus prinoides* can treat psychosis, intestinal parasites, malaria and chest pains among others (Muthaura *et al.*, 2007; Muregi *et al.*, 2006). *Myrsine africana* can manage malaria, wounds, thelminthosis among others while *sansevierria ehrenbergii* is a useful antiseptic and bandage for wounds (Gathuma *et al.*, 2004; Sileshi *et al.*, 2007; Mohammed *et al* 2007; Otieno *et al.*, 2008). *Acasia tortilis* is medicinal remedy for venereal diseases; wound healing, helminthosis while *Psiadia arabica* can treat fevers, colds, abdominal pain and helminthosis (Hagos *et al.*, 1987; Ichikawa, 1998; Bernard *et al.*, 2001; Otieno *et al.*, 2008).

The bacterial sensitivity tests were carried out using broth dilution method on the extracts of these selected plants used by herbalists in Samburu County.

5.2 MATERIALS AND METHODS

5.2.1 Preparation of plants for extraction

The aqueous and methanol/ water extracts of selected medicinal plants were prepared as described in section 4.2.1, 4.2.2 and 4.2.3

5.2.2 Preparation of Chloroformic extract of selected medicinal plants

Fourty (40) grams of powder was weighed into a conical flask and soaked in 400mls chloroform and cold maceration was done for six days during which time there was continuous shaking. The

mixture was then filtered using whatmans No. 1 filter paper. The filtrate was reduced to dryness using soxhlet apparatus. The final residue was further reduced in an oven at 40⁰c. The final extract was stored in a refrigerator at 4⁰c.

5.2.3 Evaluation of antimicrobial activity of selected medicinal plants

Test micro organisms: Stock cultures of *Neisseria gonorrhoea*, *Staphylococcus aureus*, *Escherichia coli*, *Bacillus cereus* *Pseudomonas aeruginosa* and *Streptococcus fecalis* were obtained from the Department of Public Health, Pharmacology and Toxicology, Faculty of Veterinary Medicine, University of Nairobi. The micro organism stock cultures were maintained on glycerol at 4⁰ C. The micro organisms maintained in Blood Agar were used to assess the antimicrobial activity of the aqueous and organic medicinal plant extract.

Reference antibiotics: The antibiotics benzyl penicillin, oxytetracycline and streptomycin were used as reference standards for gram positive, broad spectrum and gram negative bacteria respectively as recommended by the National Council for Clinical Laboratory Standard (NCCLS, 2000).

Sensitivity tests: Standard antimicrobial activity testing was used (Black, 1996). A loopful of stock cultures of standard organisms stored in glycerol solution was sub cultured on blood agar (BA) oxoid and incubated for 18-24 hours at 37⁰C. The sub cultured bacteria was used as stock culture and was kept at 4⁰C. After 24 hours a single colony was picked and using a sterile loop emulsified in 10mls of physiological Buffered saline (PBS) (Normal Saline). 1ml of the emulsification was taken from the tube and mixed in 9ml of normal saline in tube 1. This was diluted out in 10 folds until tube 10 to make density equivalent Macfarland opacity No. 5 containing 0.5ml of 10% barium chloride in 1% sulphuric acid and adjusted to the standard plate count method (Black, 1996). 1ml of the dilutions was taken from each tube and put into sterile

Petri dishes. This was mixed with Muller Hinton Agar (MHA) and let to solidify after which it was incubated at 37⁰c for 18-24 hours. Growth was checked for, colonies calculated and quantified in terms of colony forming units. The number of colony forming units was 2.2x 10⁷cfu/ml

Broth dilution technique (Suffredini *et al.*, 2006) was used to check for inhibitory activity of plant extract. Pre-sterilized Mueller Hinton Broth (MHB) was dispensed into sterilized 10ml test tubes using 10ml sterile pipettes. The tubes were labeled and put in a test tube rack. For test with gram positive 200mg of plant extract was dissolved in 2ml MHB while for gram negative bacteria 400mg of plant extract was dissolved in 2mls of MHB. Serial three fold dilutions of the plant extract were made. Using sterile 1ml pipette 0.1ml of bacterial suspension was dispensed into each of the test tubes. These were incubated at 37⁰c for 18-24 hours. All experiments were performed in triplicate. Another tube containing the microorganism inoculum was used as a negative control. After overnight incubation visual turbidity was noted and 0.1ml from non turbid tubes was sub cultured into MHA plates. The inocula were spread on the agar using sterile glass rods. The plates were incubated for 18- 24 hours at 37⁰c. For the positive controls three fold dilutions of streptomycin 40mg/ml, oxytetracycline 50mg/ml and benzylpenicillin at 10mg/ml were made as above for gram negative, broadspectrum and gram positive bacteria respectively. The minimum inhibition concentration (MIC) was defined as the lowest concentration that inhibited any visible growth of bacteria on the culture plates (Prescott *et al* 1999; Shahidi, 2004; Aibinu *et al.*, 2007). This was determined after the readings on the culture plates on incubation.

5.2.4.3 Data analysis

The data was entered and handled in Microsoft Excel 2007 software where descriptive statistics were generated.

5.3 Results

5.3.1 Extraction efficiency (yield) of selected medicinal plants.

The details of the amount of powder and the percent yield of the extracts of the plants studied are detailed in table 5.1. The extraction yield of the aqueous plant extract ranged from 1.38 to 10.92 grams (3.45 to 27.3%). The highest percent yield of aqueous plant extract was by *Acacia tortilis* (27.3%) followed by *Rhamnus prinoides* (17.79 %) while the lowest yield was observed with *Carissa edulis* (3.45 %) followed by *Myrsine africanas* (8.99 %). The highest percent yield of methanol/water extract was observed with *Rhamnus prinoides* 11.13gms (27.83 %) followed by *Rhamnus staddo* 8.11gms (20.28%) while the lowest percent yield of methanolic/water extract was of *Acacia tortilis* 1.34gms (3.35 %) followed by *Myrsine africana* 1.51gms (18.88%). The percent yield of the chloroformic extract was extremely low where the highest yield was observed with *Myrsine africana* 3.88gms (7.76 %) and *Ramnus staddo* 1.63gms (3.26%) while the lowest yield was provided by *Carissa edulis* 0.12gms (0.4%) and *Acacia tortilis* 0.28gms (0.56 %).

Table 5.1 Field of the selected medicinal plant species in water, methanol/water and chloroform

Plant name	Weight of Powder (mg)	Yield (mg) (aqueous)	Yield (%) (aqueous)	Yield (mg) (methanol/water)	Yield (%) (methanol/water)	Yield (mg) (chloroform)	Yield (%) (chloroform)
<i>Clerodendrum myricoides</i>	40	4.30	10.75	3.62	9.06	0.64	1.28
<i>Myrsine Africana</i>	40	3.60	8.99	1.51	18.88	3.88	7.76
<i>Carissa edulis</i>	40	1.38	3.45	5.33	13.33	0.12	0.4
<i>Rhamnus staddo</i>	40	4.50	11.46	8.11	20.28	1.63	3.26
<i>Rhamnus prinoides</i>	40	7.12	17.79	11.33	27.83	0.61	1.22
<i>Acacia tortilis</i>	40	10.92	27.3	1.34	3.35	0.28	0.56

5.3.2 The Minimum Inhibition Concentration of selected Medicinal plants.

The aqueous extract of the selected plants had antibacterial activity against the various bacterial strains used in the study except the plants *Rhamnus prinoides* and *Acacia tortilis* while the methanolic /water extracts were active against the bacterial strains used except that of *Clerodendrum myricoides*, and *Carissa edulis*. *Clerodendrum myricoides* aqueous extract was active against all strains of bacteria used except *Streptococcus fecalis* its methanol / water extract was inactive against all bacterial strains used. *Acacia tortilis* aqueous extract was not active against all bacteria strains used but the methanol/water extract was active against *Pseudomona aeruginosa* and *Escherichia coli*. Both extracts of *Myrsine africana* were active against *Bacillus cereus* and *Staphylococcus aureus* while *Carissa edulis* aqueous extract was active against *Pseudomona aeruginosa* but its methanol / water extract was not active against the bacteria strains used. *Rhamnus prinoides* aqueous extract was not active against any bacterial strain used but its methanol water extract was active against all bacteria strains except *Neisseria gonorrhoeae*. *Rhamnus staddo* aqueous extract had activity against gram positive and gram negative bacteria while its methanol/water extract showed activity against gram positive bacteria only. The concentration of the extract of all the medicinal plants used that showed antimicrobial activity was observed to be high. The details of the selected medicinal plants, the bacterial strains used, the concentration of the extracts used and the P values are in Table 5.2

Table 5.2: The minimum inhibition concentration (MIC)(mg/ml) of selected medicinal plants aqueous, methanol/water and chloroform from Samburu County

Plant species	Part used	Solvent	<i>B.cereus</i>	<i>S. aureus</i>	<i>P.aeruginosa</i>	<i>E. coli</i>	<i>N. gonorrhoeae</i>	<i>S. feacalis</i>	<i>P-value</i>
<i>C. myricoides</i>	Roots	Water	50	50	100	200	500	-	0.0844
		Methanol/water	-	-	-	-	-	-	-
<i>C. edulis</i>	Root,	Water	-	-	400	-	-	-	0.3550
	Fruit	Methanol/water	-	-	-	-	-	-	-
<i>M. africana</i>	seeds	Aqueous	400	400	-	-	-	-	0.1723
		Methanol/water	200	-	-	-	-	-	0.3559
<i>R. staddo</i>	Roots	Water	200	-	400	-	-	-	0.1996
		Methanol/water	-	200	-	-	-	-	0.1723
<i>R. prinoides</i>	Roots	Water	-	-	-	-	-	-	0.000
		Methanol/water	200	200	400	400	-	200	0.0177
<i>A. tortilis</i>	Stem	Water	-	-	-	-	-	-	0.000
	bark	Methanol/water	-	-	400	500	-	-	0.2534
CONTROL									
Streptomycin		Water	-	-	-	50	12.5	3.125	0.500
Benzylenicillin		Water	12.5	6.125	-	-	-	-	0.500
Oxtetracycline		Water	0.396	0.396	12.5	12.5	-	0.396	0.5

5.4 Discussion

In the present study the yield of the extract varied widely depending on the solvent used. The percent yield of the various extracts was most likely influenced by the polarity of the solvent together with the phytochemical present in the medicinal plant. It was also observed that the percent yield of phenols and flavonoids in selected medicinal plants in Vietnam varied with the solvent used (Nguyen and Eun, 2011)

In the current study *Clerodendrum myricoides* aqueous extract showed antibacterial activity. The antibacterial and antifungal activity has also been reported by Abebe, (1998). The plant has further been reported to be effective in treatment of protozoal diseases like East Coast Fever (Jeruto, 2008; Jeruto *et al.*, 2008). *Acassia tortilis* has been reported to be effective in the treatment of asthma and venereal diseases. It has further been reported to be effective as an anthelmintic and that it contains tannins and phenols as bioactive compounds (Hagos *et al.*, 1987; Kiringe, 2006). In the current study this plant was active against *Pseudomonas aeruginosa* and *Escherichia coli* as methanol/ water extract but no activity was recorded with the aqueous extract. In the current study *Myrsine africana* has antibacterial activity. This kind of activity has also been reported by Sileshi in Ethiopia (Sileshi *et al.*, 2007). *Carissa edulis* in this study showed antibacterial activity which was also reported by Kiringe, (2006) where the plant is used in treatment of venereal diseases. *Rhamnus prinoides* which has antibacterial activity has also been reported to treat venereal diseases (Kiringe, 2006). *Rhamnus staddo* has similarly been reported to have both antifungal and antimalarial activity when used in combination with other plants (Muregi *et al.*, 2006; Odhiambo *et al.*, 2009). It is important to note that synergism has been reported between medicinal plants and antimicrobials (Aiyegoro and Okoh, 2009), between medicinal plants and medicinal plants (Stermitz *et al.*, 2000) and also between medicinal plants

and antimalarials (Muregi *et al.*, 2006). This fact can be investigated further in the case of the plants used in this study and especially those reported to perform best when in combination. This may improve the concentration of the plant extract that show antimicrobial activity. It is also noted that a higher concentration of the plant extract is used for activity against bacteria strains used. This may suggest that the concentration of the noble molecule within the extract was low. The antimicrobial activity of the medicinal plant extract against the bacterial strains used was not statistically significant ($P>0.05$). The method of extraction together with the method of storage may also have affected the quantity of active molecule available in the extract. All the selected plants showed some antimicrobial activity which differed between the aqueous or methanol/water extract. Gram negative bacteria usually require a higher concentration of extract for activity (Suffredin *et al.*, 2006) than do the gram positive bacteria. This observation could be attributed to the cell wall of gram positive bacteria (Rang and Dale 1987) which is easier to penetrate than that of gram negative bacteria. This fact may explain why the gram negative bacteria in the present study showed a higher MIC than the gram positive bacteria. Most extracts did not show antibacterial activity even though their medicinal use has been reported in literature. This fact could be explained by the fact that many herbal medicines act as prodrugs and their activity will be seen *in vivo* and not necessarily *in vitro*. Further the herbal preparations may be subject to contamination and deterioration (WHO, 2000). This study clearly shows that the herbal remedies under study have antimicrobial activity which validates their use by Samburu traditional healers.

CHAPTER SIX

CYTOTOXICITY OF SELECTED MEDICINAL PLANT EXTRACTS FROM SAMBURU COUNTY, KENYA

6.1 INTRODUCTION

The Brine Shrimp Lethality Test (BSLT) is a general bioassay which is capable of detecting a broad spectrum of bioactivity in crude extract. The tests can predict the cytotoxicity and pesticidal activity of the extract (Pisutthanan *et al.*, 2004). A substance is considered to be cytotoxic if it inhibits vital metabolic processes or it causes disorders in living organisms resulting in perversion of behavior or death (Fatope, 1995). The brine shrimp assay basically detects substances that are cytotoxic enough to kill shrimp's larvae on exposure to solution of the sample (Ameen *et al.*, 2011). The Brine shrimp Lethality test give LC₅₀ concentrations in µg/ml which when above 1000µg/ml is considered safe but is considered toxic when below 1000µg/ml (Meyer *et al.*, 1982, McLaughlin *et al.*, 1991).

Brine shrimp lethality assay is a rapid inexpensive and simple bioassay for testing plant extracts bioactivity, the result of which in most cases correlate with cytotoxic and antitumor properties of the plant. Toxicity to brine shrimps has a good correlation with anti-tumor activity in man (McLaughlin *et al.*, 1991) since the brine shrimp responds similarly to the corresponding mammalian system (Solis *et al.*, 1993). Since the test was introduced (Meyer *et al.*, 1982), it has been used successfully for bioassay guide fractionation for active cytotoxic and antitumor agents including, trilobacin from *Asimina triloba* (Zhao *et al.*, 1992), cis-annonacin from *annona muricata* (Rieser *et al.*, 1996), Ent- kaur- 16- en- 19- oic acid from *Elaeoselinum foetidum* (Mongelli *et al.*, 2002) and Taxal from the bark of *Taxus brevifolia*. Crude plant extract can be first assayed for particular activities and the active fraction then analysed phytochemically (Hostettmann, 1991).

Brine shrimps have been used for various bioassay systems including analysis of pesticide residues, mycotoxins, stream pollutants, anaesthetics, dinoflagellates, morphine like substances, toxicity of oil dispersants, co-carcinogenicity of phorbol esters and toxicants in marine environments (Meyer *et al.*, 1982).

The plants under study have had some medicinal properties and phytochemicals reported; *Clerodendrum myricoides* is used in treatment of venereal diseases (Kiringe *et al.*, 2006; Nanyingi *et al.* ., 2008), treatment of infertility (Njoroge and Bussman, 2006), has antibacterial and antifungal activity (Yinegar *et al.*, 2008), treatment of Malaria (Muregi *et al.*, 2006 ; Jeruto *et al.*, 2008), treats epilepsy, arthritis, diabetes, typhoid, cough/cold, eye problems, proper positioning of the foetus, tonsillitis, rheumatism, East Coast Fever (Jeruto, 2008; Kalyani, 1983) among others. *Carissa edulis* has been reported to treat venereal disease (Kiringe *et al.*, 2006; Ichikawa, 1998) and in the treatment of headache, chest complaints, rheumatism, syphilis, rabies and as a diuretic (Teshome *et al.*, 2004). It contains as active phytochemicals lupeol, carissol, β -amyryn and oleuropein (Ibrahim *et al.*, 2005). This test was carried out to assess the cytotoxicity bioassay of selected medicinal plants from Samburu County, Kenya.

6.2 MATERIALS AND METHODS

6.2.1 Study area

The plant materials used for Brine shrimp Lethality tests were collected from the Samburu County (Figure 8).

6.2.2 Collection and identification of plants

The medicinal plants were identified by the herbalist at the study area, specimens were collected and taken for identification at the University of Nairobi herbarium as reported in section 3.2.3.

6.2.3 Preparation of plants and plant extract.

The Samples were prepared for extraction according to Gakuya, (2001) and these samples were extracted according to Erazo, *et al.*, (1997) and Gakuya, (2001).

6.2.4 Evaluation of bioactivity for selected plants using brine shrimp lethality test

6.2.4.1 Hatching of Brine shrimp nauplii.

Hatching of the brine shrimp was carried out according to (Gakuya, 2001). Thirty three (33) grams marine salt was weighed on an electric machine and transferred into a 1 liter conical flask. Distilled water was added concurrently and stirring done to dissolve the marine salt. When all the salt dissolved, distilled water was added to make the 1 liter mark to constitute the marine salt solution. Brine shrimp eggs acquired from the department of Public Health, Pharmacology and Toxicology, Faculty of Veterinary Medicine, University of Nairobi were hatched in shallow rectangular plastic double chambered box with a dividing wall with 1-2 mm holes. The box was filled with the constituted marine salt solution. Using a spatula 50mg of brine shrimp eggs were sprinkled and about 5mg of yeast (to act as food for the nauplii) was sprinkled in the dark compartment. The other compartment was illuminated through a hole in the lid of the box and kept under a light source using a 40 watts electric bulb. After 48 hours the phototrophic nauplii were collected using a Pasteur pipette from the lighted compartment and subjected to a Brine shrimp lethality test.

6.2.4.2 Plant extracts solution preparation.

All the aqueous and organic extracts under this study were treated in a similar manner where 0.1 grams of plant extract was weighed (Mettler PM 4600, Delta Range®) and transferred into a universal bottle. Ten milliliter of marine salt solution was added to dissolve and stirred using an

electric mixer Voltex Reamix 2789® at 2800 rpm to make a final stock concentration of 10,000µg/ml. Serial dilutions were prepared from this stock solution

6.2.4 .3 Cytotoxicity bioassay

Three dilutions were prepared by transferring 500µl, 50µl and 5µl of plant extract into the set of five graduated tubes. Ten shrimps were transferred into each of the tubes using Pasteur pipettes and marine salt was added to 5ml mark to make dilutions of 1000µg/ml, 100µg/ml and 10µg/ml. Five graduated vials were set for each dilution and a further five for the control. The tubes were left at room temperature and the number of live larvae counted after 24 hours. The percent mortality was determined for each dilution and controls. Where the deaths of controls occur within 24 hours, data was corrected using $\text{death} = (\text{test} - \text{control} / \text{control} * 100)$ (Gakuya, 2001)

6.2.5 Data Analysis

The results were interpreted using the probit method of Finney computer programme which uses the number of dose level, the number of brine shrimp for every concentration, percent mortality for every concentration and dose level. The lethal concentration (LC_{50}) and the 95 % confidence interval (UCL and LCL) were obtained using the computer programme (Mclaughlins *et al.*, 1991)

6.3. Results

The results for brine shrimp lethality tests are as shown in tables 6.1. The dilutions were in µg/ml.

6.3.1 Cytotoxicity of aqueous extract: The percent mortality of the brine shrimp larvae increased with increase in concentration of solution. For example at 10 μ g/ml *Clerodendrum myricoides* had a mortality of 4% while at 1000 μ g/ml it had a mortality of 34%. The LC₅₀ of the aqueous extract of the selected medicinal plants from Samburu County was greater than 1000 μ g/ml except for *Psiadia arabica* which had an LC₅₀ lower than 1000 μ g/ml. The LC₅₀ ranged from as low as 499.9 for *Psiadia arabica* to as high as 6921.05 for *Rhamnus prinoides*. The results are detailed in Table 6.1.

Table 6.1: Results of Brinehrimp Lethality Assay on the crude aqueous extracts of selected medicinal plants from Samburu County Kenya

Plant/conc.µ/ml	% mortality of naupli			LC ₅₀	UCL	LCL
	10 µg/ml	100 µg/ml	1000 µg/ml			
<i>Clerodendrum myricoides</i>	0.4	1.2	3.4	4242.15	-	-
<i>Myrsine africana</i>	0.2	2.0	4.2	1507.15	-	-
<i>Rhamnus staddo</i>	0.6	2.4	4.6	1261.27	-	-
<i>Carissa edulis</i>	0.2	1.0	3.0	4885.50	-	-
<i>Acacia tortilis</i>	0.2	1.4	3.4	3158.48	-	-
<i>Sansevieria enrhenbergii</i>	0.4	2.0	4.4	1462.95	-	-
<i>Rhamnus prinoides</i>	0.0	1.4	2.6	6921.05	-	-
<i>Psiadia Arabica</i>	1.0	2.4	6.2	499.90	2960.89	113.73

LC₅₀=Lethal concentration, UCL =Upper confidence level, LCL =Lower confidence level

6.3.2 Cytotoxicity of methanol water extract: The percent mortality of the brine shrimp larvae increased with increase in concentration of the solution. For example at 10µg/ml *Clerodendrum* had a 16% mortality while at 1000µg/ml had a mortality of 76%. The methanol/water extract of the selected medicinal plants from Samburu County had an LC₅₀ ranging from as low as 191.10µg/ml for *Sansevieria erhenbergii* roots to as high as 3883.55µ/ml for *Rhamnus staddo*. Three medicinal plants namely *Rhamnus staddo*, *Carissa edulis* and *Psiadia arabica* had an LC₅₀ greater than 1000µg/ml while the rest had an LC₅₀ lower than 1000µg/ml. The results are detailed in table 6.2

Table 6.2 Results of Brine shrimp Lethality Assay of the crude methanol/water extract of selected medicinal plants from Samburu County Kenya

Plant	% mortality of naupli			LC ₅₀	UCL	LCL
	10 µg/ml	100 µg/ml	1000 µg/ml			
<i>Clerodendrum myricoides</i>	1.6	3.2	7.6	204.66	3052.25	43.39
<i>Myrsine africana</i>	1.0	1.4	7.0	441.94	12865.23	122.84
<i>Rhamnus staddo</i>	1.0	2.4	3.8	3883.55	-	-
<i>Carissa edulis</i>	0.6	1.6	3.8	3195.14	-	-
<i>Sansevieria enrhenbergii</i> (roots)	1.2	4.6	7.0	191.10	3215.14	37.80
<i>Sansevieria enrhenbergii</i> (Shoots)	0.4	2.8	6.4	421.29	8068.53	120.74
<i>Rhamnus prinoides</i>	0.4	2.8	8.8	214.33	624.14	78.49
<i>Psiadia Arabica</i>	0.0	1.0	3.2	3272.64	-	

6.3.3 Cytotoxicity of chloroformic extract: The percent mortality of the brine shrimp increased with an increase in concentration of the solution. For example at 10µg/ml *Clerodendrum myricoides* had no mortality while at 1000µg/ml it had a mortality of 26%. The LC₅₀ of the selected medicinal plants from samburu showed an LC₅₀ as low as 110.40µg/ml for *Rhamnus staddo* and as high as 8553.47µg/ml for *Carissa edulis*. Three medicinal plants namely *Clerodendrum myricoides*, *Carissa edulis* and *Acacia tortilis* had an LC₅₀ higher than 1000µg/ml while the others had an LC₅₀ lower than 1000µg/ml. The results are detailed in table 6.3.

Table 6.3 Results of the Brine shrimp Lethality Assay of crude chloroform extract of selected medicinal plants from Samburu County Kenya

Plant	% mortality of naupli			LC ₅₀	UCL	LCL
	10 µg/ml	100 µg/ml	1000 µg/ml			
<i>Clerodndrum myricoides</i>	0.0	0.6	2.6	5584.44	-	-
<i>Myrsine africana</i>	0.6	0.2	7.6	320.55	2063.35	102.22
<i>Rhamnus staddo</i>	0.6	3.8	10.0	110.40	284.92	40.14
<i>Carissa edulis</i>	0.0	1.0	2.4	8553.47	-	-
<i>Acacia tortilis</i>	0.2	2.2	4.2	1463.01	-	-
<i>Rhamnus prinoides</i>	1.6	4.6	10.0	133.33	426.48	41.77

6.4. Discussion

Clerodendrum myricoides aqueous and chloroform extracts had an LC₅₀ higher than 1000µg/ml, which is quite safe and hence infers that it is non toxic. The plants methanol/water extracts however had a much lower LC₅₀ which is moderately toxic and may find use as a cytotoxic drug. These can be further investigated to verify their use as such. This plant; which is used by the traditional healers in the aqueous form is safe to use as a decoction. These results agree with Oryemo *et al.*, (2011) findings in Uganda where the methanol extract of *Clerodendrum myricoides* was more toxic than the aqueous extract. Various phytochemicals were found in both the aqueous and methanol water extract of *Clerodendrum myricoides* in the present study including terpenes, saponins, tannins, phenols glycosides among others; some of which were also identified by Oryemo *et al.*, (2011) and Jeruto *et al.*, (2008). These phytochemicals have been reported to exhibit medicinal properties including antibacterial, anti-inflammatory, antifungal, and antiviral among others (Cowan, 1999; Aguinaldo *et al.*, 2005; Arts and Hollman, 2005; Adekulne and Ikumapaye, 2006). These phytochemicals may have been responsible for the bioactivity of the extracts which further validates the plants use by the Samburu traditional healers.

Carissa edulis is safe in all the three types of extracts (aqueous, methanol/water and chloroform) and can be used as a decoction. This plant has been reported to contain phytochemicals including alkaloids, sterols and resins (Abdu *et al.*, 2008). These phytochemicals are reported to have medicinal value (Robert and Wink, 1998; Jeruto *et al.*, 2008; Abdu *et al.*, 2008) and could be attributed to the bioactivity shown by this plant. *Acacia tortilis* is safe as chloroform and aqueous extract but toxic as the methanol/water extract. This plant has been reported to contain tannins as secondary metabolites (Orwa *et al.*, 2009). These may have contributed to the

bioactivity shown by it. *Myrsine africana*, *Rhamnus staddo* and *Rhamnus prinoides* are only safe as an aqueous extract and toxic as a chloroform and methanol/water extract. *Myrsine africana* has been reported to contain various Phytochemical including tannins, saponins and flavonoids (Abbi *et al.*, 2011) which may have caused the biological activity shown by the plant. *Psiadia arabica* is safe in methanol/water extract but toxic in aqueous extract. This plant contains flavones and kaulene as bioactive compounds which can be attributed to the bioactivity shown in the study *Sansevieria enhribergii* is safe in aqueous and methanol/water extract. This plant has been reported to have antifungal activity which could be attributed to the bioactivity seen (Mohammed *et al.*, 2007). The extracts showing a low LC₅₀ (< 1000) are likely candidates for cytotoxic or anticancer drugs and can be investigated further. The extracts showing a high LC₅₀ (> 1000) can be used as non cytotoxic drugs and hence further investigations would also be called for. The reported phytochemicals in the selected medicinal plants together with the bioactivity results in this study validates the use of the plants as herbal remedies by Samburu Traditional healers.

CHAPTER SEVEN

ACUTE TOXICITY STUDIES OF THE AQUEOUS EXTRACT OF *CLERODENDRUM MYRICOIDES*

7.1 INTRODUCTION

Bent and Neuhaus (2004) reported that herbal medicines are usually taken mistakenly as safe because they are “natural”, but the products may contain bioactive principals that have potential to cause adverse effects. For this very reason Talaley and Talaley (2001) reported that it is of utmost importance to subject all herbal remedies to the efficacy and safety tests by the same methods used for new synthetic drugs. The oral acute toxic class method (ATC method) (Appendix 4) was developed as an alternative to replace the oral LD₅₀ test. The ATC method is a sequential testing procedure using only three animals of one sex per step at any of the defined dose levels. Depending on the mortality rate three but never more than six animals are used per dose level. This approach results in the reduction of numbers of animals used in comparison to the LD₅₀ test by 40–70%. The oral ATC method was adopted as an official test guideline by OECD in 1996 and was slightly amended in 2001. The oral LD₅₀ test has been deleted by OECD, by the European Union and by the USA, making the use of alternatives to the oral LD₅₀ test mandatory (OECD, 2001d).

Clerodendrum myricoides has many medicinal uses in many parts of the African continent including treatment of venereal diseases (Bussman, *et al.*, 2006, Nanyingi, *et al.*, 2008), infertility (Otieno, *et al.*, 2008), Malaria (Njoroge and Bussman 2006, Muregi, *et al.*, 2006, Muthaura, *et al.*, 2007), epilepsy, arthritis, diabetes, typhoid, cough/cold, eye problems, proper positioning of fetus, tonsillitis, rheumatism, and East Coast Fever (Jeruto, *et al.*, 2008, Jeruto, 2008), abdominal colics, and febrile convulsions (mainen, *et al.*, 2009), it has antibacterial and

antifungal activity (Abebe, 1998), among others. In view of the important utilisation of this plant as a medicinal remedy, this study was carried out to evaluate the acute oral toxicity and the histopathological effects of the aqueous extract of *Clerodendrum myricoides* (Hoechst) Vatke.

7.2 MATERIALS AND METHODS

The Acute Toxicity Testing was carried out according to the Organisation of Economic Co-operation and Development (OECD) guidelines (Schleide *et al.*, 1995, OECD 2001d).

7.2.1 Laboratory animals.

Female albino rats of winstar strain were aged 6 weeks were acquired from the Department of Public Health Kenyatta National Hospital. They were all acclimatized in the laboratory prior to the start of the experiments. The rats were randomly distributed into three groups (group 1 grp 2) grp 3) and a control group. The rats were all marked for ease of identification. All rats were maintained on a 12 hour light and darkness cycle at constant temperature (22-25)⁰C and humidity (48-50) %. They were fed with laboratory feeds and fresh clean water given *ad libitum*.

7.2.2 Dosing of animals

The oral ATC method is a sequential testing procedure with the use of three animals of one sex per step. During the development of the new study protocol the starting doses (25, 200 or 2000mg/kg b.w.) were chosen mainly from the class limits for classification of the European Union (EU) at that time (Schleide *et al.*, 1992, 1995) and modified at a later stage to 5, 50, 300 or 2000mg/kg bwt based on the class limits of the Global Harmonised classification System (GHS) (OECD, 2001d). The result of each step determines if no further testing is needed or dosing of three additional animals, with the same dose or dosing of three additional animals at the next higher or the next lower dose level. Test substance used was the aqueous extract of

Clerodendrum myricoides (Hoechst) Vatke which was a fine cocoa like powder which is hygroscopic. On absorbing moisture it is granular but the colour remains brown. When it dissolves in water it forms a brown solution. Both the extract and the solution had a bitter taste. The test substance was dissolved in drinking water and administered orally. The volume of less than 2 mls/100mg was used in various concentrations depending on the dosage. The starting dose was 2000mg/kgbw. This was followed by 300mg/kgbw. The clinical signs observed including the deaths determined the dosage that followed (OECD, 2001d).

7.2.3 Pathology and histopathology

After the experimental oral administration of the extract the dead rats were examined system by system and the lesions recorded. The visceral organs including intestines, liver, heart, spleen, brain, kidney, adrenal glands and ovary that showed pathology were removed from the body and routinely preserved in 10% formalin for histopathology.

7.2.3.1 Tissue processing for histopathology.

The tissue processing was conducted in an automatic tissue processor model Leica TP 1020 in the department of Pathology, Microbiology and Parasitology. The procedures described by Drury and Wallington, (1980) and Prophet *et al.*,1994 were followed with slight modification. The tissues were placed in 10% formalin (10 parts of formalin and 90 parts of distilled water) for 1 hour to rectify shrinkage by formalin. The tissues were dehydrated by ascending grades of isopropyl alcohol by immersing in a series of isopropyl alcohol including 70%, 80% for 1 hour each then through 90% and 96% for 1.5 hours to avoid shrinkage of cells, then in three 100% each for 1.5 hours each to ensure no traces of water in the cells. The dehydrated tissues were

cleared in two changes of xylene for 1.5 hours each. The tissues were impregnated in two changes of molten paraffin wax for two hours each to provide an internal support.

The wax impregnated tissues were embedded in paraffin wax using the same grade wax. The paraffin wax was mounted and cut with rotary microtome machine model Leica RM 2235 at 5 μ thickness. The sections were floated on a tissue flotation water bath Leica HI 1210 at 44⁰C and taken on plain glass slides. The cut sections were then transferred to an incubator at 53⁰C overnight and cooled ready for staining.

7.2.3.2 Tissue staining

The staining procedures described by Prophet *et al.*, (1994) were followed. The sections were deparaffinised by immersing into two changes of xylene for 2 minutes each in a horizontal staining jar. The deparaffinised sections were washed in two changes of 100% isopropyl alcohol, then 95% alcohol. They were then dipped in cold water and stained in Meyer's hematoxylin for 8-12 minutes in a horizontal staining jar. The sections were then blued in tap water for 10-15 minutes to wash out the excess hematoxylin in other structures and make the nuclei distinct. The sections were counter stained with eosin for 5 minutes (the cytoplasm and other organelles stain varying shades of pink to red but the nucleus stains blue). The sections were counter stained in 1% aqueous eosin (1gm in 100mls water) for 5 minutes and the excess was washed in tap water. Complete dehydration of stained sections was ensured by placing the sections in graded alcohol including 95%, 100%, 100% for 5 minutes each. The sections were then mounted in DPX having the optical index of glass (the sections were wetted in xylene and inverted onto the mount and placed onto the cover slip. The slides were observed at low power under the microscope. The cell injury and over aspects were observed under high power dry objective (Dunn, 1974). After

mounting the slides were left on the table to air dry for microscopic observation and evaluation. The slide imaging was carried out using Carl Zeiss photographic microscope. Model: German-176045 and cannon camera PC1200. The haematoxylin and eosin stained images were read and the pathological lesions described at Mg X400.

7.2.4 Data analysis

Data Analysis of the ATC method is as detailed in Appendix 4. The principle of the ATC method is based on the Probit model (Finney, 1971).

7.3 RESULTS

7.3.1 Effects of aqueous extract of *C. myricoides* on rats.

The signs observed included respiratory system signs, musculoskeletal system signs, nervous system signs and circulatory system signs. Table 7.1(Appendix 7) displays the clinical signs of acute toxicity observed after oral administration of the extract.

7.3.2 Pathology and Histology of the animals that died and those that survived for the two weeks test period.

The organs that had lesions included the liver, the spleen, the lungs and the kidney. These lesions included congestion, pale areas especially on the liver and organ enlargement. The histopathology of the liver showed mainly congestion at the dosage of 2000mg/kgbw (Figure 15). The lungs showed mild congestion and lymphocytic infiltration, (Figure 12) the kidney showed mild congestion (Figure 13) and the spleen showed a depopulation of lymphocytes leaving pockets of white pulp and only the red pulp was seen (Figure 14). These lesions were mainly observed in the 2000mg/kgbw dosage of the extract.

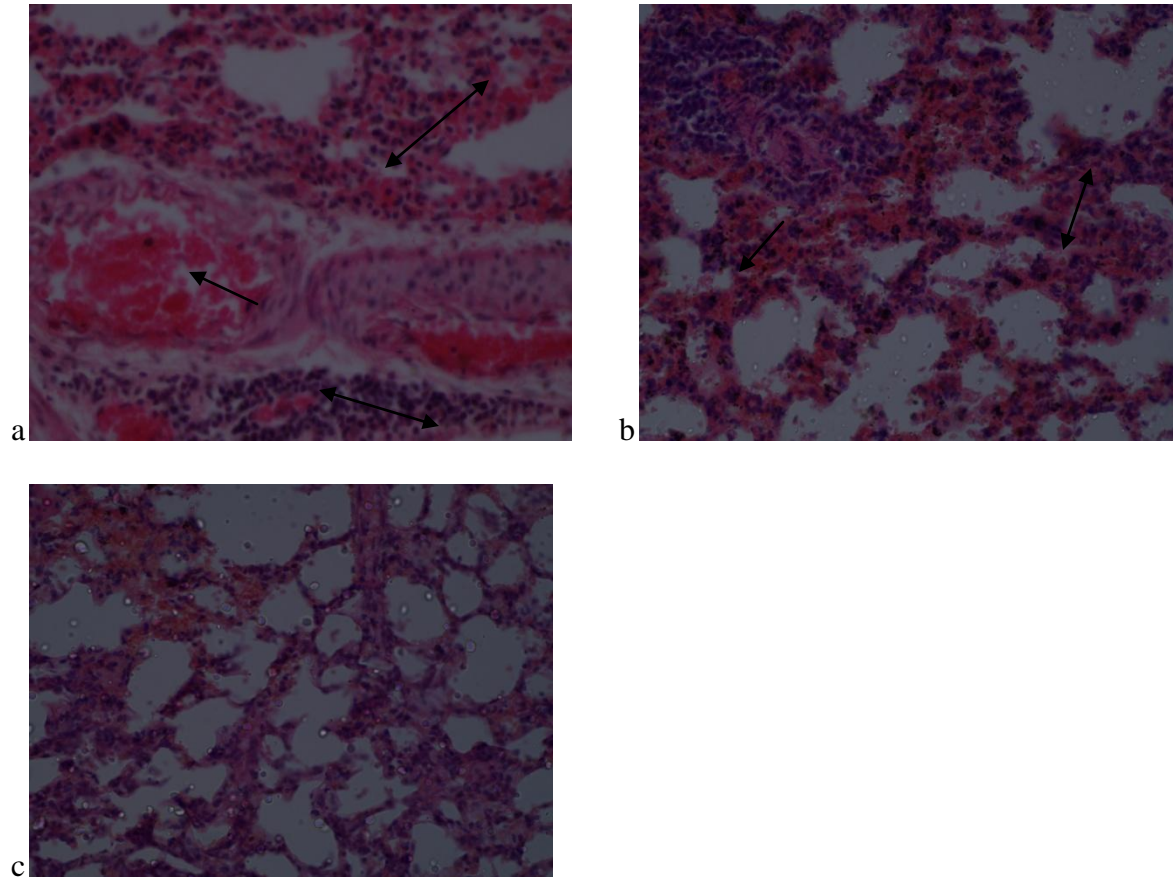

Figure 12: Photomicrograph of the Lung showing congestion and vasculitis a; at dosage of 2000mg/kgbw black arrow showing congestion, double arrow showing thickening of vascular wall and collapse of alveoli, b; mild congestion and vascular wall thickening with collapsed alveoli at 300mg/kgbw and c; control. H and E stain. Mg x400

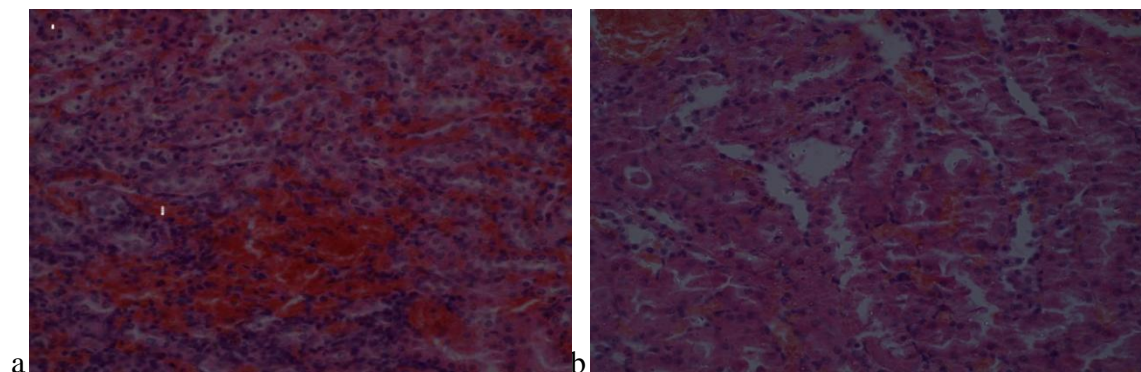

Figure 13: Photomicrograph of the Kidney showing mild congestion. a;2000mg/kgbw and b;control. H and E stain. Mgx400

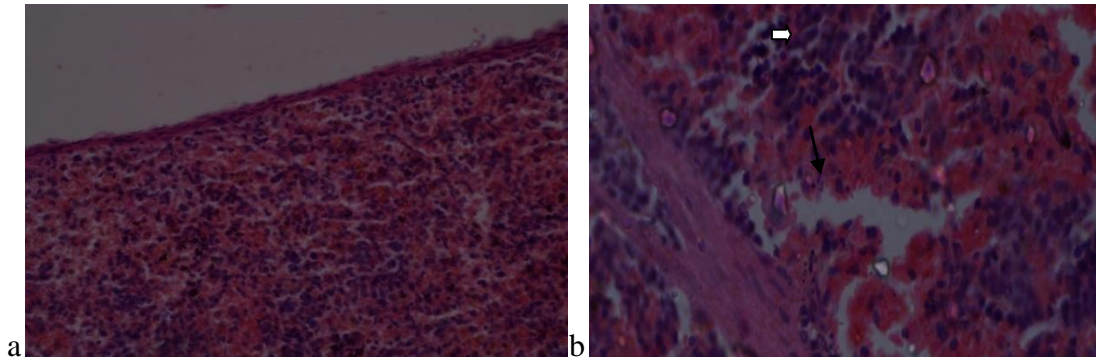

Figure 14: Photomicrograph of the spleen showing depopulation of lymphocytes. a; 2000mg/kgbw, and b; control (white pulp white arrow and red pulp black arrow). H and E stain; Mgx400

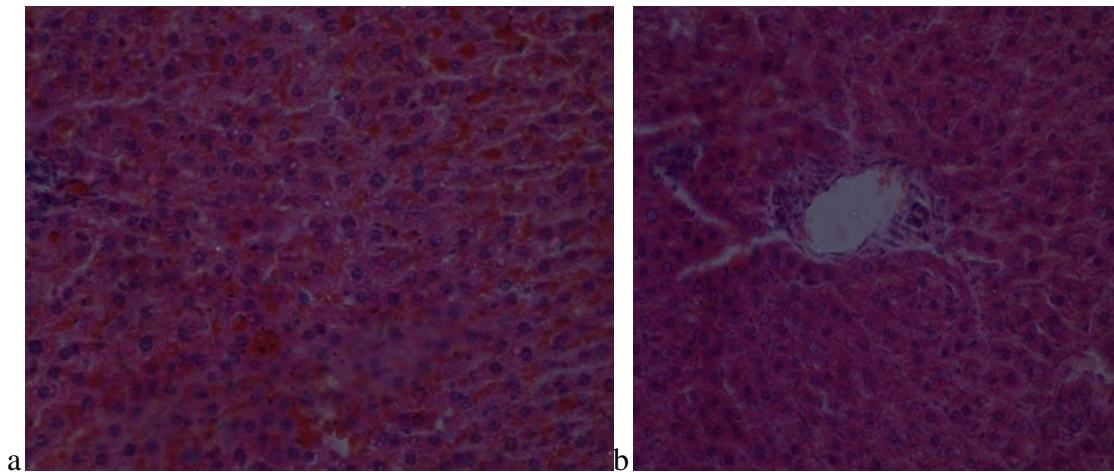

Figure 14: Photomicrograph of the liver showing congestion. a; 2000mg/kgbw and b; control. H and E stain. Mgx400

7.4 Discussion

In the present study two animals died within the 24 hour period at 2000mg/kg bwt but none of the animals died at 300mg / kg bwt dosage. More over various clinical signs were observed as adverse effects on the rats which included nervous signs like; convulsions, forelimb paresis, hypersensitivity, photophobia, dyspnoea, salivation, laccrimation among others (table 7.1). The acute toxic class method revealed that the medicinal plant was slightly toxic with an LD₅₀ of 1000mg/kg bwt (Appendix 4). This is in accordance with Matsumura (1975) who classifies toxicity as extremely toxic when the LD₅₀ is less than 1mg/kg bwt, highly toxic when the LD₅₀ is between 1 and 50 mg/kg bwt, moderately toxic when the LD₅₀ is between 50 and 500mg/kg bwt, slightly toxic when LD₅₀ is between 500 and 5000 mg/kgbwt, practically non toxic when LD₅₀ is between 5000 and 15000 mg/kgbwt and relatively harmless when LD₅₀ is greater than 15000mg/kg bwt. This observation agrees with Hayelom *et al.*, (2011) that *Clerodendrum myricoides* root aqueous extract is slightly toxic where the LD₅₀ was reported as 1134mg/kgbwt.

At the dosage of 2000mg/kgbwt the aqueous extract affected the liver, the kidney, the spleen and the lungs. The lesions included congestion as the main lesion in the lungs, liver and kidney. There was further lymphocytic infiltration in the lung blood vessels. The lymphoid tissue in the spleen was further depopulated. Similar toxic effects of the plant on the liver and kidney of mice have been reported by Hayelom, *et al.*, (2011).

CHAPTER EIGHT

STUDY OF SUB-ACUTE TOXICITY OF AQUEOUS EXTRACT OF *CLERODENDRUM MYRICOIDES* (HOECHST) VATKE

8.1 INTRODUCTION

Literature indicates that medicinal plants have been essential in many communities for primary health care. They are often the only therapeutical resource (Nereyz *et al.*, 2012). García-Cortés *et al.*, (2008) has reported that the uses of medicinal plant-derived medicines have been on the increase in the past few decades in many countries, due to the wrong perception that their being "natural" makes them beneficial with no health risks. In developing countries, medicinal plants are widely used for food, economic, and medicinal purposes. However there is scanty information available on the toxicology of these plants. Further evidence on the toxicity risks associated with a wide variety of such remedies has emerged in the last few years, including hepatotoxicity among others (Norris *et al.*, 2008). This is caused by the ability of the plants phytochemicals to cause organ damage. This occurs after interaction of a series of complex cellular processes involved in their pharmacological activities (Udem and Ezeasor, 2010).

The genus *Clerodendrum* has found a wide use as an important medicinal plant world over. In Kenya, it has been reported to have medicinal value against Malaria (Muregi *et al.*, 2006). In Ethiopia Hayelom *et al.*, (2011) has reported a wide range of medicinal uses including antimalarial activity, antibacterial activity, anti snake bite among others. In Indian, Chinese, Japanese and Thailand traditional medicine this important plant has been useful in the treatment of life threatening diseases such as cancer, hypertension among others (Shrivastava and Patel 2007). Further the plant has been reported to contain major phytochemicals important in treatment of various ailments (Shrivastava and Patel 2007). In view of the importance the genus

presents, this study was carried out to elucidate the subacute toxicity of the aqueous extract of the species *Clerodendrum myricoides* (Hoechst) Vatke

8.2 MATERIALS AND METHODS

8.2.1 Laboratory animal

Healthy young albino rats, winstar strain were used in the present study. The female rats were nulliparous and non-pregnant. The animals were allowed to acclimatize for 7 days. The temperature in the experimental animal room was 22-25°C. The relative humidity was 48-50%. Lighting was artificial, the sequence being 12 hours light, 12 hours dark. Laboratory feeds were sourced from Unga Feeds Kenya Ltd and distilled clean water was supplied *ad libitum*. Animals were housed in cages in small groups of five of the same sex. The animals were identified uniquely and kept in their cages for at least seven days prior to the start of the study to allow for acclimatisation to the laboratory conditions.

8.2.2 *Clerodendrum myricoides* aqueous extract

The test compound was administered via the drinking water according to the test groups. The control group received food and drinking water like the rest of the rats but without the test substance.

8.2.3 Treatment of animals.

The animals were divided into three test groups and a control group with each group consisting of five female and five male rats at 300mg/kg bwt, 150mg/kg bwt and 75mg/kg bwt. Except for treatment with the test substance, animals in the control group were handled in an identical manner to the test group animals. The body weights of all the rats were recorded at the start of the experiments and at weekly intervals thereafter. Dose levels were selected taking into account

the acute toxicity data. A descending sequence of dose levels were selected with a view to demonstrating any dosage related response and no-observed-adverse effects at the lowest dose level (NOAEL). Two fold intervals were used for setting the descending dose levels. The animals were dosed with the test substance daily for a period of 28 days. The maximum volume of liquid that was administered at once depended on the size of the test animal. The volume did not exceed 2ml/100g body weight. Test volume at all dose levels was ensured by adjusting the concentration of the test substance to ensure a constant volume at all dose levels.

The health condition of the animals was recorded at least twice daily; all animals were observed for morbidity and mortality.

Behavioral changes were noted in all animals before the administration of the extract and once a week thereafter and recorded. Observations were made outside the cage in a standard area at the standard time. Signs noted included; changes in skin, fur, eyes, and mucous membranes, occurrence of secretions and excretions and autonomic activity (e.g. lacrimation, piloerection, pupil size, and unusual respiratory pattern). Changes in gait, posture and response to handling and the presence of clonic or tonic movements, stereotypes (e.g. excessive grooming, repetitive circling) or bizarre behaviour (e.g. selfmutilation or walking backwards) were also recorded.

Sensory reactivity to stimuli of different types (e.g. auditory, visual and proprioceptive stimuli), assessment of grip strength and motor activity assessment was conducted at the end of the four weeks of the experiment.

8.2.4 Body weight and food/water consumption

All animals were weighed at least once a week. Measurements of food consumption were made at least weekly. Since the test substance was administered via the drinking water, water consumption was measured weekly.

8.2.5 Haematology

Blood samples were taken from the orbital sinus of rats using needles and syringes. Haematocrit, haemoglobin concentration, erythrocyte count, total and differential leucocyte count and platelet count were determined pretreatment and weekly thereafter.

8.2.6 Clinical Biochemistry

Clinical biochemistry determinations to investigate the functions of the test organs (kidney, heart muscle and liver), were also performed on blood samples obtained from animals fortnightly. Determinations of plasma or serum included; urea, creatinine, total protein and albumin levels. Activities of alanine aminotransferase and aspartate aminotransferase were also carried out. The animals were fasted overnight prior to blood sampling.

8.2.7.7 Pathological examination

8.2.7.7.1 Gross necropsy

All animals in the study were subjected to complete gross necropsy which included careful examination of the external surface of the body and all orifices. The cranial, thoracic and abdominal cavities and their contents were also observed. The liver, kidneys, adrenals, testes, epididymis, thymus, spleen, brain and heart of all animals; (apart from those found moribund and/or intercurrently killed) were trimmed of any adherent tissue, as appropriate, and their wet weight taken immediately after dissection to avoid drying.

The following tissues were preserved in neutral buffered 10% formalin (PH 7.2) for subsequent histopathological examination: all gross lesions, brain (representative regions including cerebrum, cerebellum and pons), spinal cord, stomach, small and large intestines (including Peyer's patches), liver, kidneys, adrenals, spleen, heart, thymus, thyroid, trachea and lungs,

gonads, accessory sex organs (e.g. uterus, prostate), urinary bladder, lymph nodes, peripheral nerve (sciatic) and a section of bone marrow

8.2.7.7.2 Histopathology

Full histopathology was carried out on the preserved organs and tissues of all animals in the control and high dose groups. These examinations were extended to animals of all other dosage groups, in the treatment-related changes observed in the high dose group.

8.2.8 Data Analysis

Results of parametric tests were expressed in terms of mean±SEM. In the assays involving comparison of more than two means, one-way ANOVA was used. Significance was set at $P < 0.05$.

8.3 Results

8.3.1 Behavioral changes

At 300mg / kg bwt piloerection, itching and huddling together were observed among both males and female rats (Figure 16). At 150mg/kgbw the rats were observed with piloerection, were unwilling to move and appeared weak. Shivering, dyspnoea and pale ears were additionally noted in the females. At 75mg/kgbw the main symptom was piloerection. The control group showed no clinical signs. These signs were exhibited within the first 24 hours. Nevertheless they remained throughout the study period with the rats showing increased intensity of itching. At the rostrum and the ear lobes the rats had wart like lesions (Figure 16). These were exaggerated in the 300mg/kgbw dosage. At 75mg/kgbw the changes were few but absent altogether in the control group.

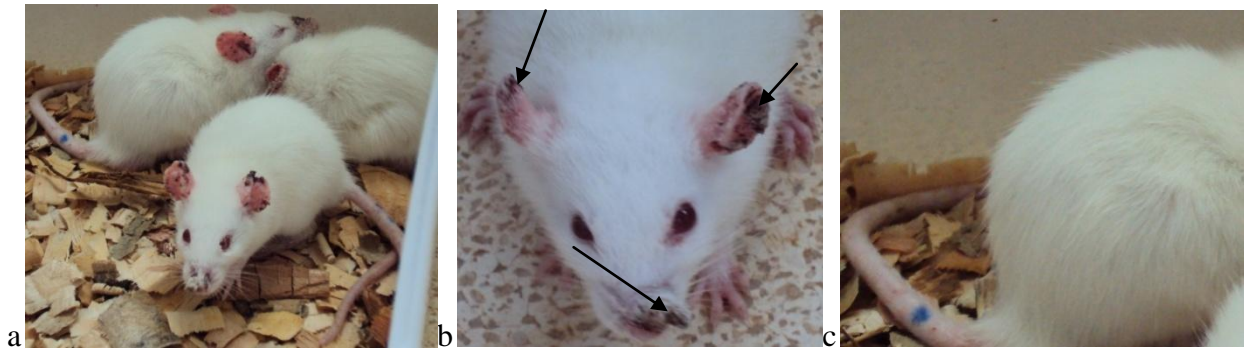

Figure 16: Photographs of rats exhibiting Clinical signs after sub acute toxicity study: a; rats huddling together, b; rats with wart like lesions, c; rat showing piloerection.

8.3.2 The body weight of rats.

The body weights of the animals increased significantly in all the test groups as compared to the control group (Table 8.1). The organ weights similarly showed a significant increase in weight in the test groups although this was not dose dependent (Table 8.2).

8.3.3 Biochemical parameters

The significant changes observed in the clinical biochemistry parameters of the test groups were either not dose dependent or they were within the normal range (Table 8.3)

8.3.4 Haematological parameters

The white blood cells parameters increased significantly in the test groups with the administration of the plant extract as compared to the control group. The increase was dose dependent but within the normal range. Similarly the neutrophils increased significantly in the test groups as compared to the control group but the lymphocytes decreased significantly in the test group as compared to the control group. The significant observations in the test groups on the red blood cells, haematocrit volume, Haemoglobin concentration and mean corpuscular volume were not dose dependent (Table 8.4)

Table 8.1: Comparison of mean weight \pm SEM among aqueous extract of *C. myricoides* treated groups at dosages of 75mg/kgbw, 150mg/kgbw and 300mg/kgbw for both males and female

	Body weight (g)				
	Initial	Week 1	Week 2	Week 3	Week 4
Male					
Control	95.04 \pm 5.73	104.2 \pm 11.19	121.6 \pm 8.67	143.3 \pm 12.34	114 \pm 16.33
75 mg/kg	60.06 \pm 13.15	72.69 \pm 28.99	85.02 \pm 27.23	96.54 \pm 32.6	88.62 \pm 31.58
150 mg/kg	65.60 \pm 3.34	53.52 \pm 5.62	65.45 \pm 6.90	72.93 \pm 5.50	76.39 \pm 5.82
300 mg/kg	80.21 \pm 14.88	84.23 \pm 7.65	94.03 \pm 6.18	98.13 \pm 8.27	93.91 \pm 10.09
Female					
Control	138.6 \pm 15.15	154.4 \pm 17.18	173.8 \pm 19.29	161.8 \pm 16.82	174.7 \pm 16.15
75 mg/kg	75.52 \pm 11.19	79.37 \pm 12.40	88.97 \pm 11.29	94.71 \pm 11.91	111.3 \pm 6.15
150 mg/kg	65.52 \pm 6.55	47.41 \pm 6.29	58.12 \pm 5.26	68.01 \pm 6.77	68.96 \pm 4.0
300 mg/kg	65.11 \pm 15.49	78.3 \pm 20.54	88.59 \pm 18.15	92.43 \pm 11.54	79.93 \pm 5.64

Table 8.2: Mean organ-weight values \pm SEM of the rats over the 28- day period in the control group, 75mg/kgbw/150mg/kgbw and 300mg/kgbw for both male and female

	Organ weight (g)						
	Heart	Intestines	Kidney	Liver	Lungs	Spleen	Stomach
Male							
Control	0.74 \pm 0.18	22.91 \pm 3.93	2.01 \pm 0.37	9.28 \pm 1.24	1.79 \pm 0.94	1.26 \pm 0.85	3.51 \pm 0.7
75 mg/kg	0.46 \pm 0.13*	11.86 \pm 2.87*	1.06 \pm 0.16*	4.7 \pm 1.29*	1.2 \pm 0.52	0.61 \pm 0.05	1.75 \pm 0.26 *
150 mg/kg	0.38 \pm 0.18*	9.73 \pm 4.19*	0.93 \pm 0.34*	3.6 \pm 2.05*	1.02 \pm 0.58	0.33 \pm 0.22	1.31 \pm 0.54 *
300 mg/kg	0.52 \pm 0.20	13.2 \pm 2.40*	1.05 \pm 0.23*	4.48 \pm 0.998*	1.18 \pm 0.13	0.76 \pm 0.22	2.34 \pm 0.75 *
Female							
Control	0.76 \pm 0.03	19.2 \pm 3.40	1.88 \pm 0.09	9.14 \pm 0.93	1.90 \pm 0.25	0.85 \pm 0.21	2.98 \pm 0.76
75 mg/kg	0.4 \pm 0.20*	8.68 \pm 3.7*	0.75 \pm 0.28*	2.35 \pm 1.57*	0.68 \pm 0.41*	0.24 \pm 0.25*	1.57 \pm 0.65 *
150 mg/kg	0.22 \pm 0.05*	7.0 \pm 1.7*	0.52 \pm 0.19*	1.66 \pm 0.39*	0.68 \pm 0.14*	0.15 \pm 0.03*	1.14 \pm 0.4*
300 mg/kg	0.66 \pm 0.32	15.3 \pm 5.13	1.10 \pm 0.18*	4.96 \pm 1.90*	1.49 \pm 0.53	0.56 \pm 0.28	2.14 \pm 0.6

*significantly different from control, P<0.05. Values expressed as means \pm SEM

Table 8.3: Clinical blood chemistry values of female and male rats at the fourth week of treatment

In the sub acute toxicity test of aqueous extract of *Clerodendrum myricoides* (Hoechst Vahl).

	CONTROL	75 mg/kg bwt	150 mg/kg bwt	300 mg/kg bwt
Female				
Total protein (g/dl)	7.68± 0.850	6.68±0.526	5.68±3.027	6.86±0.713
Albumin (g/dl)	3.4± 0.453	2.9± 0.270	3.52±0.572	2.72±0.444
Alanine aminotransferase(U/I)	5±3.317	33.4±6.914	59.4± 8.503*	20.4±9.864
Aspartate aminotransferase(U/I)	28.2±5.805	7±2.556	34.2±6.140*	10.8±3.633*
Blood urea nitrogen(mg/dl)	25.28±5.070	31.8±7.463	36.4±4.827	27.12±6.571
Creatinine(mg/dl)	0.46±0.152	6 ±0.2	0.58±0.217	0.7± 0.158*
Male				
Total protein (g/dl)	9.54±1.563	6.32±0.661	6.78±0.5260*	8.18±4.76
Albumin (g/dl)	3.06±0.503	2.64±0.550	2.64±0.503	3.24±1.006
Alanine aminotransferase(U/I)	9.2±3.493	32.3±9.257*	10.8±3.564	22.2±9.121*
Aspartate aminotransferase(U/I)	14.6±16.40	6.2±3.194	10±6.442	7.4±3.975
Blood urea nitrogen(mg/dl)	29.48±6.785	25.64±5.095	29.54±5.149*	26.82±8.760*
Creatinine(mg/dl)	0.6±0.2	0.52±0.130	0.32±0.130*	0.6±0.158

*significantly different from control, P<0.05. Values expressed as means ± SEM

Table 8.4. Haematological values of Male and Female rats in the Sub acute toxicity test of the aqueous extract of *Clerodendrum myricoides* (Hoechst) Vahl

	CONTROL	75mg/kgbw	150mg/kgbw	300mg/kgbw
Females				
White blood cells x 10 ⁶ /μl	11358±1534	15458±477.7*	15926±772*	17701±3375*
Red blood cells x 10 ⁶ /μl	6.962±3.745	7.074±0.178	47.88±0.890*	6.926±0.356
Haematocrit volume (%)	42.36±3.745	47.8±1.367*	47.88±0.890*	42.74±2.203
Haemoglobin concentration(g/dl)	14.86±0.727	13.9±0.245	13.58±0.606*	15.14±0.730
Mean corpuscular volume(fl)	62.04±4.315	67.76±2.131*	13.58±0.606*	61.22±0.983
MCHC(g/dl)	35.2±1.754	34.38±4.235	36.06±0.961	36.96±0.730
Thrombocytes x 10 ³ / μl	511±265.7	522.2±117.9	499.6±27.72	628.8±145.5
Total Neutrophils (%)	25.8±6.340	40±3.808*	37.2±2.168*	42±1.581*
Mature Neutrophils (%)	25.8±6.340	40±3.808*	37.2±2.168*	42±1.581*
Immature Neutrophils (%)	0±0	0±0	0±0	0±0
Lymphocytes (%)	72±5.339	54.4±3.050*	64±2.646*	53.4±1.673*
Eosinophils (%)	0±0	0±0	0±0	1±1.414
Monocytes (%)	0±0	0±0	0±0	0.2±0.477
Basophils (%)	0±0	0±0	0±0	0±0
Nucleated Red blood Cells (%)	0±0	0.2±0.447	0±0	0±0

*significantly different from control, P<0.05. Values expressed as means ± SEM

8.3.5 Gross Pathology

Gross examination of the liver at 300mg/kgbw showed pale areas and was icteric in some rats. The lesion severity decreased with the decrease in dosage. At the 75mg/kgbw the lesion was not identified. The control group showed a normal liver. The lung was slightly inflamed at the 300mg/kgbw. This lesion was not seen in 150mg/kgbw and 75mg/kgbw dosages. The kidney had a normal gross appearance.

8.3.6 Histopathology

Microscopic examination of the liver at 300mg/kgbw showed congestion and vasculitis. The lungs showed oedema and vasculitis, while the kidney showed mild congestion. The spleen showed a depopulation of lymphocytes with only the red pulp remaining. (Figures 17, 18, 19, 20)

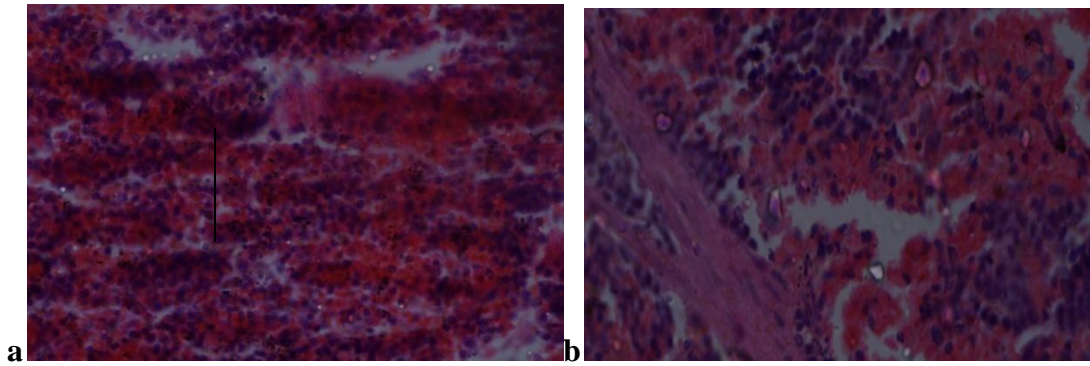

Figure 17: A microphotograph of the histological section of the spleen showing depopulation of lymphocytes. a; at a dosage of 300mg/kgbw repeated dose for 28 day(black line). b; control. H and E stain. Mg x 400

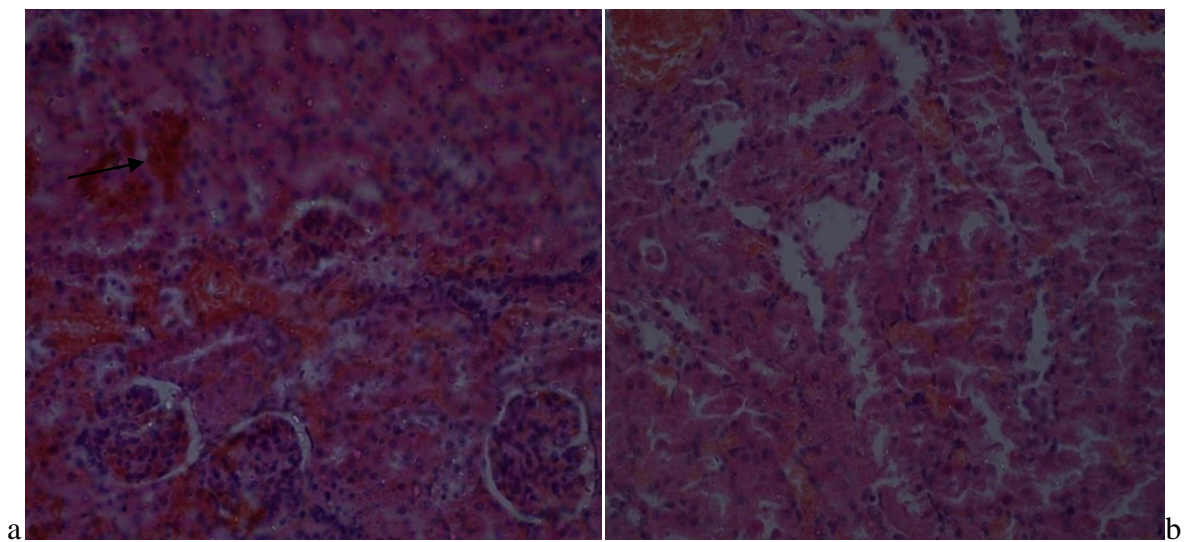

Figure 18. A microphotograph of the histological section of the kidney showing mild congestion. a; at the dosage of 300mg/kgbw repeat dose for 28 days (arrow). b; control.

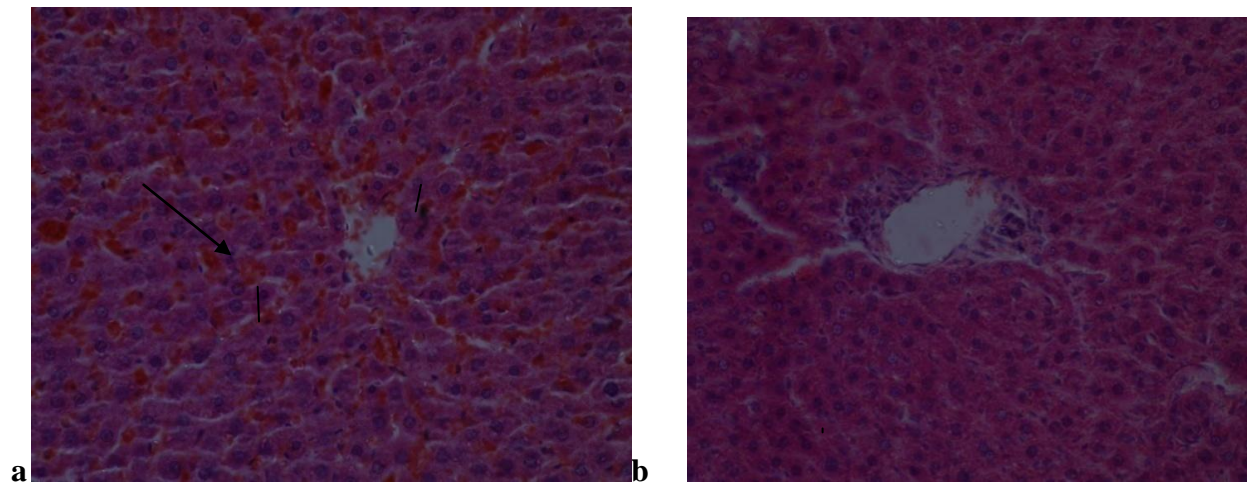

Figure 19: A microphotograph of the histological section of the Liver showing mild congestion (arrow) and vasculitis (line). a; when treated with 300mg/kgbw repeat dose for 28 days b; control. H and E stain. Mg x 400.

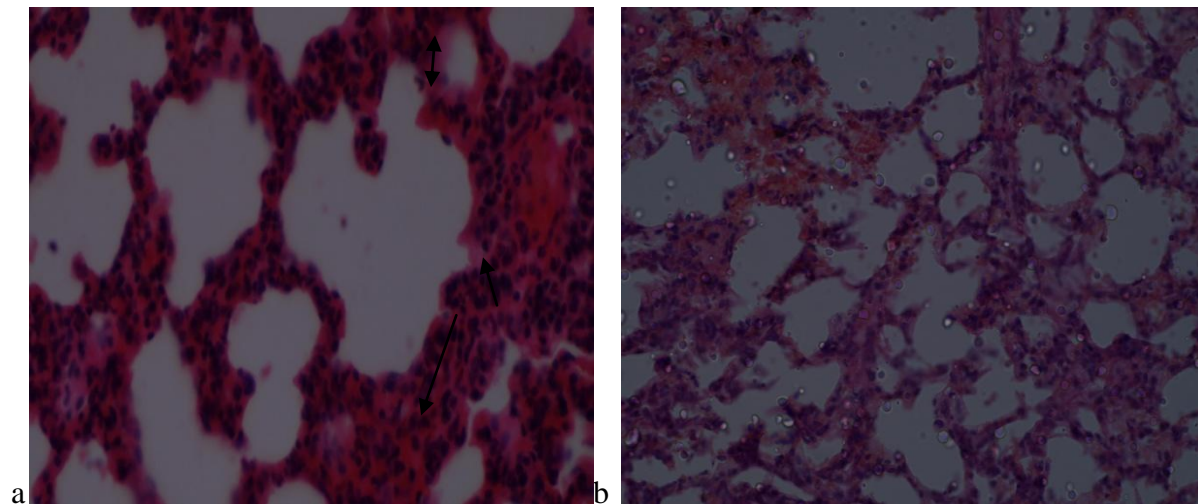

Figure 20: A microphotograph of the histological section of the lung showing vasculitis (single arrow). a; when treated with 300mg/kgbw repeated dose for 28 days. b; control, H and E stain. Mg x 400

8.4 Discussions

In the present study the clinical symptoms seen during the 24 hours period and during the study period showed that the aqueous extract of *Clerodendrum myricoides* indeed elicited signs of toxicity in the Laboratory animals indicated by behavioural changes including dyspnoea, piloerection, huddling together, scratching among others as has been recorded by other authors (Chan *et al.*, 1982, OECD, 1995, Auletta, 2002).

According to Teo *et al.*, (2008) and Obici *et al.*, (2008), body weight changes are usually an indication of the adverse side effects as the animals that survive cannot lose more than 10% of the initial body weight. Body weight changes have also been used as an indicator of the side effect of drugs and chemical substances (Santos *et al.*, 2009). The body weight measurements in this study in all the dosages increased significantly as compared to the control group indicating that perhaps the extract did not affect the animals' body weight negatively but rather positively. The extract may be of some nutritional value, an assumption that may need further investigation. According to Wonder *et al.*, (2011) changes in organ weights are equally important indices of toxicity in animals which can be determined in short term toxicity tests. Further there is a high possibility that herbal products when ingested into the body may be toxic to important organs including the kidney, liver, spleen, stomach and lungs due to their diverse roles in the human body. In the present study the organ weights differed significantly from the control although this was not dose dependent; an observation which may be attributed to differences in physiological processes and metabolism in different animals.

The continued administration of the extract similarly affected the biochemistry and the haematological profile of the animals respectively. The gross pathology and histopathology also indicated that the extract mainly affected four major internal organs including, the spleen which

was mostly affected, the liver, lung and the kidney which were mildly affected. In the biochemical analysis some significant changes were observed although they were not exactly dose dependent and others were within the normal range. The biochemical analysis is quite important because there are reported cases of both renal and liver toxicity as a result of use of phytotherapeutics (Corns, 2003). In preclinical toxicity studies renal changes are most likely to occur due to the high doses usually given and the fact that the kidneys eliminate many drugs together with their metabolites (Greaves, 2007).

In the present study the kidney markers used included blood urea nitrogen and creatinine. The significant change in serum blood urea observed was within the normal limit while the change in serum creatinine was not dose dependent. Further the histopathological observation of the kidney only revealed some mild changes in terms of congestion at the 300mg/kgbw dosage. The lack of marked changes in the serum levels of blood urea and creatinine suggests that the histopathological changes in the kidney may not have been significant enough to affect kidney function and therefore may be considered as toxicologically unimportant.

Alanine aminotransferase (ALT), Aspartate aminotransferase (AST) are important markers of liver function (Arneson and Brickell, 2007). Alanine aminotransferase is localized in the cytosol of the hepatocytes and hence can provide a better quantitative assessment of liver damage than Aspartate aminotransferase. (Aniagu *et al.*, 2004).

In the present study the significant serum level change of ALT was not dose dependent and that of AST was within normal range. Further the histopathological changes observed within the liver were mild which further suggests that these changes may not affect the liver function and therefore may be considered of no important toxicological value. The liver produces most of the plasma proteins including albumin and globulins. In the present study the total proteins and

albumin were not significantly different from the controls except in the females at the 300mg/kgbw an observation that could be purely artefactual as was also observed by Aniagu *et al.*, (2004).

Blood parameters analysis is relevant to risk evaluation as the haematological system has a higher predictive value for toxicity in humans (91%) when data are translated from animal (rodents and non rodents) studies (Olson *et al.*, 2000). Blood forms the main transport media for many drugs and xenobiotics in the body hence components of the blood are at least initially exposed to a significant concentration of toxic compounds. Damage to and destruction of blood parameters will inevitably affect normal body functions.

In the present study the observation on the haematological factors showed that the significance was not dose dependent which may have been completely artefactual. Further the White blood cells (WBC), the Neutrophils (Total and mature) and the Lymphocytes were all significantly different from the control group. The white blood cells increased significantly and the increase was dose dependent although it was within the normal range. The Neutrophils increased significantly and the increase was above the normal range although not dose dependent. The Lymphocytes reduced significantly from the control but within normal range. It is also noted that the histopathological picture of the spleen showed depopulation of lymphocytes and lymphocytic infiltration in the lung and the liver. These results suggest that the aqueous extract of *Clerodendrum myricoides* (Hoechst) Vatke may have an immune stimulating agent. Similar observations were made by Mu *et al.*, (2011) and Neyrez *et al.*, (2012). This suggestion may however require further investigation to quantify.

In conclusion oral toxicity of the aqueous extract of *Clerodendrum myricoides* Hochst (Vatke) is slight but since these results can not be extrapolated to humans the results should be used with caution.

CHAPTER NINE

GENERAL CONCLUSION AND RECOMMENDATIONS

9.1 Conclusions

The following conclusions were made based on the results of the current study;

- i) Use of herbal medicine is important for the management of sexually transmitted infections by Samburu traditional healers and several plants are used mainly in combination.
- ii) Extracts of *Clerodendrum myricoides* obtained from Samburu County Kenya, contain several phytochemicals that include alkaloids, triterpene, saponins, tannins, phenols cardiac glycosides and resins. These phytochemicals may be responsible for the pharmacological and toxicology actions of the plant. The plant does not contain steroids, flavonoids, anthraquinones or proteins.
- iii) Based on the results of the brine shrimp lethality test, majority of medicinal plants used in Samburu for management of STI can be considered to be safe to the patients since they had an LC_{50} value of at least $1000\mu\text{g/ml}$.
- iv) Plants used by Samburu traditional healers for management of STIs have *invitro* efficacy against most bacteria used. The aqueous extract of *Clerodendrum myricoides*, the most used plant has some gram negative and gram positive antibacterial activity.
- v) The 24 hour oral median lethal dose (LD_{50}) of aqueous extract of *Clerodendrum myricoides* in rats was found to be 1000mg/kgbw . It was therefore concluded that the extract was slightly toxic and therefore safe for oral use as a single dose. Doses above 2000 mg/kg are toxic. The clinical signs in acute toxicity occur mainly in the central nervous system, respiratory system and the musculoskeletal system.

- vi) It was concluded that repeated administration of the aqueous extract of *Clerodendrum myricoides* may be associated with subacute toxicity.
- vii) In subacute toxicity at dosages ranging from 75 to 300 mg/kg body weight, the lesions of poisoning with *Clerodendrum myricoides* extracts are dose dependent and the organs affected included the liver, lungs, kidney and spleen.
- viii) Repeated administration of *Clerodendrum myricoides* extract causes changes in biochemical values. The parameters affected included levels of alanine aminotransferase, aspartate aminotranferase, blood urea nitrogen and creatinine. The extract does not affect total protein or abumin levels.
- ix) Administration of *Clerodendrum myricoides* is associated with some haematological changes and the parameters affected include WBC and RBC counts, haematocrit, netrophil and lymphocyte counts and MCV.
- x) *Clerodendrum myricoides* is slightly toxic and it should be used with caution after appropriate data on acceptable dosages have been formulated. However, more work will require to be carried out to ascertain the acceptable dosage for the formulation available for use.

9.2 Recommendations

The following recommendations were made;

- i) Traditional healers in Samburu may continue using remedies for treating STIs. However studies to evaluate these medicinal plants for quality safety and efficacy are needed despite the remarkable claims made for their effectiveness..

- ii) Further studies are needed for minimization of the toxic effects of *C. myricoides* while maintaining the claimed medicinal values of the plant extract. Appropriate dosage should be determined.
- iii) More prolonged toxicity studies after administration of *Clerodendrum myricoides* by different routes should be undertaken to generate more data on the toxic effects of the plants. This should include both subacute and chronic toxicity studies.

Further studies are required to isolate the active constituents of *C. myricoides* and to elucidate their mechanism of their toxic effect.
- iv) Detailed phytochemical studies should be done to characterize the phytochemicals found in medicinal plants in Samburu County and determine the ones responsible for pharmacological and toxicological properties.
- v) The traditional healers in Samburu County Kenya should be encouraged and facilitated to develop commercial medicinal products based on traditional knowledge. This should be done in collaboration with research institutes that would provide the required pharmacological and toxicological profiles of these medicinal plants. Such products should be subjected to value addition chains and considered for registration and regulation by the medical industry.

REFERENCES

- Abbi, V., Joseph, L., George, M. (2011):** Phytochemical analysis of fruit extract of *Myrsine africana*. International journal of pharmacy and pharmaceutical Research **3**: 427-430.
- Abdu, K. B., Khan, M. E., Rumah, M. M. (2008):** Antimicrobial activity and Phytochemical screening of extracts from the root bark of *Carissa edulis* against human/animal pathogens. Continental Journal of Tropical Medicine **2**: 1-6.
- Abebe, D. (1998):** The role of medicinal plants in healthcare coverage of Ethiopia, the possible Benefits of integration In: Conservation and sustainable use of medicinal plants in Ethiopia, Proceedings of the National workshop, 28 April – 01 May 1998. Edited by: Zewdu M. Addis Ababa. Demissie A: Institute of Biodiversity Conservation and Research; **2001**: 6-21.
- Aberra, G., Dawit, A., Asfaw, D., Zewdneh, M., Frehiwot, A. Frehiwot, T., Tesfaye, K., Kelbessa, U., Kidist Y., Teklele B., Bisrat H. M. and Mulugeta, G.Y., Teklele, B., Bisrat, H. M. & Mulugeta, G. (2005):** Screening of some medicinal plants of Ethiopia for their antimicrobial properties and chemical profiles. Journal of Ethnopharmacology **97**: 421-427
- Acharya, D., Shrivastava, A. (2008):** Indigenous Herbal Medicines: Tribal Formulations and Traditional Herbal Practices, Aavishkar Publishers Distributor, Jaipur- India. ISBN pp. 440

- Adekulne A. A, Ikumapayi A.M. (2006):** Antifungal Property and Phytochemical Screening of the Crude Extracts of *Funtumia elastica* and *Mallotus oppositifolius*. *West Indian Medical Journal*. **55**: 219-223.
- Aguinaldo, A. M., Espeso, E. I., Guevara, B.Q., Nonato, M. G. (2005):** Phytochemistry. In: Guevara, B. Q. (ed.) *A Guidebook to Plant Screening: Phytochemical and Biological Screening*. University of Santo Tomas, Manila, Philippines. Cited in
- Sermakikani, M., Thangapandian, V. (2010):** Phytochemical screening for active compounds in *Paedaliun marex* L. *Recent research in scienceand technology*, **2**: 110-114.
- Aibinu, I., Adenepekun, T., Adelowotan, T., Ogunsanya, T., and Odugbeni, T. (2007):** Evaluation of antimicrobial properties of different parts of *Citrus aurantifolia* (lime fruit) as used locally. *African Journal of Traditional and Alternative Medicine*; **4**: 185-190.
- Aiyegoro, O.A., Okoh, A. I. (2009):** Use of bioactive plant products in combination with standard antibiotics: Implications in antimicrobial chemotherapy. *Journal of Medicinal Plants Research*; **3**: 1147-1152.
- Altunc, U., Pittler, M. H., Ernst, E. (2007):**"Homeopathy for Childhood and Adolescence Ailments: Systematic Review of Randomized Clinical Trials", *Mayo Clinic Proceedings* **82**: 69–75.
- Ameen, O.M., Usman, L. A., Oladosu, I. A., Olawore, N. O., Ogunwande, I.A. (2011):** Bioactivity of rhizome essential oils from two varieties of *Cyperus articulatus* L. Grown in Nigeria, using brine shrimp (*Artemia salina*) lethality tests. *Journal of Medical Plant Research*; **5**: 1031-1033.
- Amrit P. S., (2005):** Promising Phytochemicals from Indian Medicinal Plants. *Ethnobotanical*

Leaflets **9**: 15- 23.

Aniagu, S.O., Mwinyi, F. S., Olanubi, B., Akumka, D. D., Ajoku, G. A., Izebe, K. S., (2004):

Is *Berlina grandiflora* toxic in rats? Phytomedicine; **11**: 352-360.

Angell M., Kassirer J, P., (1998): "Alternative medicine the risks of untested and unregulated remedies". The New England Journal of Medicine **339**: 839–41.

Ang – Lee. M., M., Yuan, C. S., (2001): Herbal medicines and perioperative care.

Journal of American Medical Association. **286**: 208 – 216.

Arneson, W., Brickell, J., (2007): Assessment of Liver function. In: Arneson, W. and Brickell,

J.ed. Clinical Chemistry: A laboratory perspective 1st edition Philadelphia: F. A. Davis

Company; p 201-232

Arts, I.C., P Hollman, .C. (2005): Polyphenols are disease risk in epidemiological studies.

American. Journal of .Clinical. Nutrition. **81**: 317-325

Atsamo, A.D., Nguelack, T. B., Dalle, J. Y., Kamanyi, A, (2011): Acute, Subacute and

chronic oral toxicity assessment of the aqueous extract from the stem bark of *Erythrina*

Sene galensis D. C. (*Fabaceae*) in rodents. Journal of Ethnopharmacology, **134**: 697-702.

Atwood, K. C. (2003): "Neurocranial Restructuring" and Homeopathy, Neither Complementary

nor Alternative", Archives of Otolaryngology - Head and Neck Surgery **129**: 1356-1357.

Auletta, C. S. (2002): Acute, Sub chronic and Chronic Toxicology. In: Derelanko, M.

J. Hollinger, M. A. editors. Handbook of Toxicology. USA: CRC press Inc. Pg 69-86.

Avert.org. <http://www.avert.org/stdstatisticsworldwide.htm>. Retrieved 2011-01-09.

- Azene, B., Birnie, A., Tengnas, B. (1993):** Useful trees and shrubs for Ethiopia. Regional Soil Conservation Unit (RSCU), Swedish International Development Authority (SIDA). Nairobi.
- Baer, H. A. (2001):** "The sociopolitical status of U.S. naturopathy at the dawn of the 21st century". *Medical Anthropology Quarterly* **15**: 329–346.
- Bandarayanake, W. M. (2002):** Bioactivities, bioactive compounds and chemical constituents of mangrove plant. *Wetlands Ecological Management* **10**: 421-452.
- Baron, S. (1996):** *Medical Microbiology* 4th edition. Galveston (TX). University of Texas Medical branch at Galveston. chapter 5. Introduction to Infectious diseases. Available from <http://www.ncbi.nlm.nih.gov/books/NBK8009/> Retrieved 12/7/2013
- Bashwira, S., Hootelé, C., Tourwé, C., Pepermans, H., Laus, G. and Van Binst, G (2001):** *Cleromyrine I*, a new cyclohexapeptide from *Clerodendrum myricoides* *Tetrahedron* **45**: 5845-5852
- Barret, S. (2007):** "Be Wary of Acupuncture, Qigong, and "Chinese Medicine". Quackwatch. <http://www.quackwatch.org/01QuackeryRelatedTopics/acu.html>. Retrieved 6/4/2010
- Beentje, H.J. (1994):** Kenya trees, shrubs and lianas. National museums of Kenya, Nairobi. p.722.
- Benedict, L. (2002) cited in: Whorton, J. C.:** Nature cures: the history of alternative medicine in America. Oxford: Oxford University Press. p. 224.
- Bensky, D., Clavey, S and Stoger, E. (2004):** Eds. *Chinese Herbal Medicine: Materia Medica*, Third Edition
- Bent, P. A. Neuhaus, J. (2004):** Safety and efficacy of citrus aurantium for weight loss. *American Journal of Cardiology* 2004: 1359-61 Pubmed.

- Bent, S., Tiedt, T. N., Odten, M. G., Shlipat, M. G. (2003):** The relative safety of ephedra compared with other herbal products. *Annals of Internal medicine*. **138**: 468 – 470
Pubmed.
- Bent, S. (2008):** Herbal Medicine in the United States: Review of Efficacy, Safety, and Regulation. *Journal of General Internal Medicine* **23**: 854-859
- Bent, S., Ko, R. (2004):** Commonly used herbal medicines in the United States: A review. *American Journal of Medicine*; **116**: 478-485.
- Bernard, F. J., Yenesew, A., Midiwo, J. O. Waterman, P.G. (2001):** Flavones and Phenylpropanoids in the exudate of *Psiadia punctulata*. *Phytochemistry*. **57**: 571-574.
- Berkenwald, A. D. (1998):** "In the Name of Medicine". *Annals of Internal Medicine* **128**: 246–250 (<http://www.annals.org/cgi/content/full>)
- Black, J. (1996):** Growth and Culturing of Bacteria: Microbiology principles and application, 3rd edition, Prentice Hall, New Jersey pp140-142.
- Bonhoeffer, S., Lipsitch, M., Levin, B. R. (1997):** Evaluating treatment protocols to prevent antibiotic resistance. *Proceedings of the National Academy of Science USA* **94**: 12106-12111.
- Bratman, M.D., Steven (1997):** The Alternative Medicine Sourcebook. Lowell House. p.7.
- Breevort, P. (1998):** The Booming U. S. Botanical Market: A New Overview. *HerbalGram* **44**: 33-46.
- Bronfort, G. Haas, M. Evans, R. Leininger, B. Triano, J. (2010):** "Effectiveness of manual therapies: the UK evidence report". *Chiropractic and Osteopathy* **18**: 3.
- Brown, K. M., Arthur, J.R. (2001):** "Selenium, selenoproteins and human health: a

- review". *Public health nutrition* **4**: 593
- Bruel, V. D. A., Haj Hassan, T., Thompson, M., Buntixn, F., Manti, D. (2010):** Diagnostic value of clinical features at Presentation to identify serious infection in children in developed countries: A systemic review. *Lancet* **375**: 834-845.
- Burkill, H.M. (1994):** Useful plants of West Tropical Africa. Vol. 2. Families E-I. Royal Botanical Gardens, Kew.
- Burkill, H.M. (1995):** The useful plants of West Tropical Africa. 2nd edition. Vol.3 Families J-L, Royal botanical gardens, Kew, Richmond United Kingdom 636 pp.
- Busse, J.W., Morgan, L. Campbell, J. B. (2005):** "Chiropractic antivaccination arguments". *Journal of manipulative and physiological therapeutics* **28**: 367–373.
- Bussman R.W. (2006).** Ethnobotany of the Samburu of Mt. Nyiro, South Turkana, Kenya. *Journal of Ethnobiology and Ethnomedicine* **2**: 35
- Bussmann, R. W. Genevieve G. G., John S., Manja L., Rumpac L., Kimaren K., Nick W. and Simon G. M. (2006):** Plant use of the Maasai of Sekenani Valley, Maasai Mara Kenya. *Journal of Ethnobiology and Ethnomedicine*, **2**: 22.
- Camillia M. (2006):** "Seeing the Body: The Divergence of Ancient Chinese and Western Medical Illustration. *Journal of biocommunication* **32**.
- <http://www.sesp.northwestern.edu/docs/publications/> (Retrieved 28/9/2010)
- Caulfield, T., Debow, S. (2005).** "A systematic review of how homeopathy is represented in conventional Complementary and Alternative Medicine peer reviewed journals." *BMC Complementary and Alternative Medicine* **5**: 12 (<http://www.pubmedcentral>) (Retrieved 15/8/2010)

Central bureau of statistics Kenya. (1999). Population and Housing Census, counting our people for development. Ministry of Finance and Planning, Ed Government of Kenya.

Chakraborti, D., Mukherjee, S. C., Saha, K. C., Chowdhury, U. K., Rahman, M. M., Sengupta, M. K. (2003). "Arsenic toxicity from homeopathic treatment." Journal of toxicology. Clinical toxicology **41**: 963–967.

Chan, P. K., Ottara, G.P., Hayes, A. W., (1982): Principles and Methods for Acute and Sub acute Toxicity. In: Hayes, A. W. Editor. Principles and Methods of Toxicology, Newyork, Ravens Press. Pg 17-19.

Chawau, P., Joshi, K., Patwadhan, B., (2006): DNA microarray in herbal and drug research. Evidence based Complementary and Alternative Medicine **3**: 447-457.

Chen, T. H., Chang, H. C., and Lue, K. Y. (2009): "Unregulated Trade in Turtle Shells for Chinese Traditional Medicine in East and Southeast Asia: The Case of Taiwan". Chelonian Conservation and Biology **8**: 11–18. <http://www.bioone.org/doi/abs/>

Choudhury, R. P., Ibrahim, A. M. D., Bharathi, H. N., and Venkatasubramanian, P. (2007): Quantitative Analysis of Embelin in *Myrsine africana* L. *Myrsinaceae* using HPLC and HPTLC. Electronic Journal of food and plants chemistry **2**: 20-24.

Chun-Fa, H., Shing-Hwa, L. and Shoei-Yn L. S. (2007):"Neurotoxicological effects of cinnabar (a Chinese mineral medicine, HgS) in mice". Toxicology and Applied Pharmacology: **224**: 192-201,

Cindy, E. (2002): How Animals Keep Themselves Well and What We Can Learn From Them.

In: Wild Health: Houghton Mifflin Publishing Company. (www.wildhealth.co.uk/author/)

Retrieved 20th may 2010

Clarke, E. C. G., Clarke, M. L. (1977): Veterinary Toxicology. London. Cassel and Collier

Macmillan: 1977. pp 268-277

Cowan, M. M (1999): Plant Products as Antimicrobial Agents. Clinical Microbiology **Review 1**

2: 564-582.

Cooper, R. A. Mckee, H. J. (2003): "Chiropractic in the United States: trends and issues".The

Milbank quarterly **81:** 107–138.

Corns, C. M. (2003): Herbal remedies and clinical biochemistry. Annals of Clinical

Biochemistry **40:** 489-507

Cucherat, M; Haugh, M. C. Gooch, M. Boissel, J. P. (2000): "Evidence of clinical efficacy of

homeopathy. A meta-analysis of clinical trials. Homeopathic Medicines Research

Advisory Group." (HMRAG), European Journal of clinical pharmacology **56:** 27–33,

Dagenais, S. Budgell, B. (eds.) Principles and Practice of Chiropractic (3rd edtn.). McGraw Hill.

pp. 23–64.

Day M. (1998): Bacteriocins and bacteriophages. In: Collier, L., Balows, A., Sussman, M.,

editors. Topley & Wilson's microbiology and microbial infections. 9th ed. Vol.2.London:

Arnold **1998** p. 185-193.

De-Lucca, A., Cleveland, T., Rajasekara, K., Boue, S. and R. Brown, R. (2005): Fungal

properties of CAY-1, a plant saponin, for emerging fungal pathogens.

45th interscience conference in antimicrobial agents and chemotherapy Abstract, **F-490**

Pp: 180.

De Smet, P. A. (2002): Herbal medicines IV. English Journal of Medicine; **347**: 2046-2056.

Desta, B. (1995): Ethiopian traditional herbal drugs. Part I: Studies on the toxicity and therapeutic activity of local taenicidal medications. Journal of Ethnopharmacology. **45**: 27-33.

DeVocht, J.W. (2006): "History and overview of theories and methods of chiropractic: a **444**: 243–249

Drury, R. A. B., Wallington, E. A., (1980). Carleton's histological techniques 5th ED. Oxford University Press. Oxford, Newyork, Toronto 188-189 237-240 290-291.

Dzubak, P., Hajduch, M., Vydra, D., Hustova, A., Kvasnica, M., Biedermann, D., Markova, L., Urba, M., Sarek, J. (2006): Pharmacological activities of natural triterpenoids and their therapeutic implications. Natural Products. Reports. **23**: 394-411.

Elaine, E. Nina, L. E. www.eolss.net/sample-chapters/CO3/E6-79.pdf (retrieved 15/2/2013)

Erazo S., Gonza´lez V., Zaldivar M. and Negrete R. (1997): Antimicrobial activity of *Psoralea glandulosa* L. International Journal of Pharmacology **35**: 1-3.

Ernst, E (2010): "Deaths after chiropractic: a review of published cases". International Journal of Clinical Practice **64 (8)**: 1162–1165

Ernest E. (2008): Harmless herbs. A review of recent literature. American Journal of Medicine. **104**:170-178 pubmed.

- Ernst, E (2005):** "Is homeopathy a clinically valuable approach?", Trends in Pharmacological Sciences **26:** 547–548.
- Ernst, E. (2002):** "A systematic review of systematic reviews of homeopathy", British Journal of Clinical Pharmacology **54:** 577–582,
- Ernst, E.; Pittler, M.H. (1998):** "Efficacy of Homeopathic Arnica: A Systematic Review of Placebo-Controlled Clinical Trials", Archives of Surgery **133:** 1187–1190
- Ernst, E; White, A. R. (1995):** "Homoeopathy and immunization", The British Journal of general practice **45:** 629–630
- Evans, W. E. , McLead, H. L. (2003).** Pharmacogenomics-drug disposition, drug targets and side effects. New England journal of medicine 348: 358-549. Cited in Toxicokinetics-Variations due to genetics or interactions: (www.gth.org/cms/images/stories/media). Retrieved 21/5/2014
- Fabio, F., Luigi, G. (2007):** Herbal medicine today: Clinical and research issues. Evidence based Complementary and Alternative Medicine **4:** 37-40
- Fabricant D. S., Farnsworth N. R. (2001):** The value of plants used in traditional medicine for drug discovery". Environmental Health Perspecive. 109 Supplement **1:** 69–75.
- Fang, J. Y. (2010):** The toxicity of natural products
(www.mdpi.com/journal/toxins/special_issues/natprod-toxicity). Retrieved 10/5/2013
- Fatope, M. O. (1995):** Phytocompounds. Their Bioassay and Diversity. Discovery and Innovations **7:** 229-236.

- Felix M., Bauer, M. (2006):** "The Final Days of Traditional Beliefs? - Part One". Chinese Medicine Times **1**: 31. (<http://www.chinesemedicinetimes.com>).
- Ferez, C. A., Madalasso, R. C., Roche, O. A., Leite, J. P. Guimaraes, J. M., Toledo, U. P., (2006).** Acute and chronic toxicological studies of *Dimorphandra mollis* in experimental animals. Journal of Ethnopharmacology **108**: 450-456.
- Finney, D. J. (1971):** Probit Analysis. 3rd ed. Cambridge University Press, Cambridge.
- Gakuya, D. (2001):** Pharmacological and clinical evaluation of anthelmintic activity of *Albizia anthelmintica* Brogn, *Maerua edulis* De Wolf and *Maerua cordata* De Wolf plant extracts I sheep and mice. PhD University of Nairobi, Department of Veterinary Clinical Studies. 157 pp.
- García-Cortés, M., Borraz, Y., Lucena, M. I., Peláez, G., Salmerón, J., Diago, M., Martínez-Sierra, M. C., Navarro, J. M., Planas, R., Soria, M. J., Bruguera, M., Andrade, R. J. (2008).** Liver injuries induced by "natural remedies": an analysis of cases submitted to the Spanish Liver Toxicity Registry. Rev Esp Enferm Dig 100: 688-695. (<http://dx.doi.org/>) Retrieved 23/01/2013
- Gathuma, J. M., Mbaria, J. M., Wanyama, J., Kaburia, H. F. A., Mpoke L. Mwangi, J. N. (2004)** Efficacy of *Myrsine africana*, *Albizia anthelmintica* and *Hilderbrandtia sepalosa* herbal remedies against mixed natural sheep helminthosis in Samburu district, Kenya. Journal of Ethnopharmacology **91**:7-12
- Getahun, A., (1976.):** Some common medicinal and poisonous plants used in Ethiopian folk medicine. Addis Ababa University, Pp 62-63

Girish, D., Shridhar, D. (2007). History of medicine (<http://medind.nic.in/iae/to7/i4.iae/to714>).

Retrieved 10/2008

Githiori, J.B. (2004): Evaluation of Anthelmintic Properties of Ethnoveterinary Plant Preparations Used as Livestock Dewormers by Pastoralists and Small Holder Farmers in Kenya. Doctoral thesis.

Gogtay, N.J., Bhatt, H.A., Dalvi, S. S., Kshirsagar, N. A. (2002): "The use and safety of non-allopathic Indian medicines". *Drug Safety* **25**: 1005–1019.

Gregg, L.V. (2000). Hematology Techniques and Concepts for Veterinary Technicians. IOWA, USA. IOWA State University Press. Anemias and Polycythenias; pg 95-101.

Greaves, P. (2007). Histopathology of preclinical toxicity studies: Interpretation and Relevance in drug safty and evaluation. 3rd edition. Newyork Academic press.

Gundling, K. E (1998): "When did I become an "allopath"? (Commentary)". *Archives of Internal Medicine* **158**: 2185–2186.

Gustafson, R. H., Bowen, R. E. (1997): Antibiotic use in animal agriculture. *Journal of Applied Microbiology*; **83**: 531-541.

Hagos, M., Samucisson, G., Kenne, L. and Modawi, B. M.(1987): Isolation of smooth muscle relaxing 1, 3-diaryl-propan-2-ol derivatives from *Acacia tortilis*. *Planta Médica* **53**: 27-31.

Harding, A. (2006): "Beijing's penis emporium". www.chinahistoryforum/topics/Retrieved June 23, 2010.

Harkey, M. R., Henderson, G. L., Gershwin, M. E., Stern, G. S., Heckman, R. M., (2001):

Variability in commercial ginseng products: an analysis of 25 preparations. American Journal of Clinical Nutrition **73**: 1101-1106.

Handa, S. S., Khanuja, S. P. S., Longo, G., Rakesh, D. D. (2008): Extraction Technologies for

Medicinal and aromatic Plants. United Nations Industrial Development Organisation

(UNIDO), International Centre for Science and Higher Technology

(www.unido.org...Extraction-technologies-for-medicinal-and-aromatic-plants.pdf).

Retrieved 13/7/2013

Harborne J.B. (1973): Phytochemical Methods; A guide to modern techniques of plant

Analysis. 2nd Edition, London New York.

Harborne J.B. (1984): Phytochemical Methods; A guide to modern techniques of plant

Analysis. 3rd Edition, London New York

Harborne, J. B. (1998): Phytochemical Methods. J. B. Harborne ed. Chapman and Hall London.

Cited in, **Nonita, P.P., Mylene, M. U., (2010).** Antioxidant and cytotoxic activities and

phytochemical screening of four Philippine medicinal plants. Journal of medicinal plants research

4: 407-414

Hardman, J. G.; Limbird, L. E. (1996) Eds. The Pharmacological Basis of Therapeutics, 9th

edition, McGraw-Hill (www.arthritistoday.org)

Hayelom, K., Mekebeb, A., Eyasu, M., Wondwossen, E. Kelbesa, U. (2011). The effect of

Clerodendrum myricoides aqueous extract on blood, liver and kidney tissues of mice.

Medicinal Ethiopian Journal of Science **3**: 48-63

Heinrich, M. Bremner, P. (2006): Ethnobotany and Ethnopharmacy; Their role for anticancer development. *Current Drug Targets* **7**: 239-245

Helwig, D. (2010): "Traditional African medicine". *Encyclopedia of Alternative Medicine*.

Hill, A.F., (2008): *Economic Botany. A text book of useful plants and plant products* 2nd Edn. McGraw-Hill book company, Inc, New York.

Hong, T. D., Linington, S. Ellis, R. H. (1996): *Seed storage behaviour: a compendium*. Handbooks for Genebanks: No. 4. IPGRI.

Hoppal, M. (1987). Shamanism. <https://en.wikipedia.org/wiki/shamanism/>

Homola, S. (2006): "Can Chiropractors and Evidence-Based Manual Therapists Work Together? An Opinion From a Veteran Chiropractor". *The Journal of Manual and Manipulative Therapy* **14**: E14–E18.

Hostettman, K. (ed) (1991): *Methods in Biochemistry, vol. 6. Assays for Bioactivity*, Academic press London.

<http://.aanmc.org/naturopathic-medicine/the-6-principles.php>, (retrieved 4/10/2011)

<http://books.google.com/>. *Medicine in America (illustrated ed.)*. New York: Oxford University Press. pp. 18, 52. (Retrieved 13/6/2012)

<http://en.wikipedia.org/wiki/sansevieria> (retrieved 13/10/2010)

http://en.wikipedia.org/wiki/osteopathy#cite_ref_0cite_ref-0 (retrieved 29/7/2011)

http://en.wikipedia.org/wiki/osteopathy#cite_ref-guide_1-0#cite_ref-style_guide_1-0 (Retrieved 3/10/2010)

(http://en.wikipedia.org/wiki/Sansevieria_ehrenbergii)

http://en.wikipedia.org/wiki/Traditional-Chinese-medicine#cite_ref-4 The Classic of Difficulties (45th Difficulty) (Wikipedia)(Retrieved 4/6/2012)

http://en.wikipedia.org/wiki/Traditional-Chinese-medicine#cite_ref-5 The Classic of Categories (Retrieved 12/3/2011)

<http://gateway.nlm.nih.gov/meetingabstract/ma?f=102184948.html> (retrieved 13/2/2010)

<http://gosai.com/ayurveda-and-allopathy#Ayurveda> (2007). Ayurveda and Allopathy (Retrieved 2/5/2011).

<http://highered.mcgraw-hill.com/classware/infoCenter.do?isbn>. Cowan Microbiology Student Study Site.(Retrieved 20/5/2013)

<http://kitsrus.com/pdf/nejm.pdf>. (Retrieved 5/6/1013)

<http://nccam.nih.gov/health/whatiscam/>.2006."What is Complementary and Alternative Medicine (CAM)?" . National Center for Complementary and Alternative Medicine. "(Retrieved 4/5/2010)

<http://nccam.nih.gov/health/naturopathy/D372.pdf>."Naturopathy: An Introduction" (PDF).

National Center for Complementary and Alternative Medicine. 2007. Retrieved 20 Nov 2010.

<http://www.ama-assn.org/ama/no-index/about-ama/13638.shtml>. (Retrieved 12/6/2009)

<http://www.bls.gov/oco/ocos074.htm> Physicians and Surgeons". Occupational Outlook Handbook. U.S. Department of Labor. Retrieved 2010-04-28.

<http://www.cancer.org/Treatment/TreatmentsandSideEffects/ComplementaryandAlternativeMedicine/MindBodyandSpirit/naturopathic-medicine>. Retrieved 20 Nov 2010.

<http://www.cancer.org/TreatmentandSideeffects/ComplementaryandAlternativemedicine/ManualHealingandPhysicalTouch/acupuncture>. Acupuncture, American Cancer Society, Retrieved 23/10/2010

<http://www.complete-herbal.com/index.html>) (Retrieved 13/6/2012)

<http://www.eolss.net/EOLSS-sampleAUChapter.aspx> (retrieved 15/2/2013).

http://www.fsmb.org/pdf/GRPOL_essentials.pdf/ Essentials of a Modern Medical and Osteopathic Practice Act, Federation of State Medical Boards. Retrieved Nov 201

<http://www.indianmedicine.nac.in> (retrieved 20/06/2009)

http://www.law.cornell.edu/uscode/html/uscode42usc_sec_html/US Code: Recognition that osteopathic physicians can be appointed as commissioned officers in the US Public Health Service (Retrieved 11/4/2010)

[http://www.law.cornell.edu/uscode/html/uscode10/usc_Html/US Code: Requirements for appointment of osteopathic physicians as commissioned officers in the Armed Forces Medical Corps](http://www.law.cornell.edu/uscode/html/uscode10/usc_Html/US%20Code%20Requirements%20for%20appointment%20of%20osteopathic%20physicians%20as%20commissioned%20officers%20in%20the%20Armed%20Forces%20Medical%20Corps) (Retrieved 12/3/2012)

<http://www.nap.edu/catalog.php?record>(Retrieved 11/11 2012)

<http://www.oialliance.org> (retrieved 13/5/2010)

http://www.purac.com/purac_com/ (retrieved 12/4/2010)

<http://www.princetonview.com/medicalresearch/decide/allopathic.asp> "Allopathic" Medicine - The Princeton Review (a college admissions testing preparation company unaffiliated with Princeton University) (Retrieved 4/10/2011)

<http://www.pubmedcentral.nih.gov/articlerender.fcgi?tool=pmcentrez&artid>(Retrieved 2/8/2012)

http://www.purac.com/purac_com/67/php Institute of Medicine (2005). Complementary and Alternative Medicine in the United States. National Academy Press. (Retrieved 3/6/2010)

http://www.purac.com/purac_com/php (Applications for lactic acid).Wikipedia (Retrieved 5 2 2011)

<http://www.thieme-connect.com/ejournals/abstract/> (retrieved 4/3/2010)

<http://www.wisegeek.com/> (Retrieved 5/5/2013)

<http://www.woho.org/> (retrived 12/11/2009)

Hutchings, M.R., Athanasiadou S., Kyriazakis, I., Gordon, I. J. (2003): "Can animals use foraging behavior to combat parasites?" Proceedings Nutritional Society **62**:361.

Ibrahim., R.O. Bolaji., E.M.Abdurahman., M. Shok., N., Ilyas. and A.G. Habib. (2005): Preliminary Phytochemical and antimicrobial studies of the leaves of *Carissa edulis* Vahl. Chem Class Journal **2**: 15-18

Ichikawa, M. (1998): The Mbuti Pygmies in the Ituri forest of north-eastern Zaire, around Katala and Mawambo village (N 1.0', E 29.10', alt. c. 1000 m), Zone de Mambasa, Region de Haut-Zaire in: AFLORA on the Web <http://130.54.103.36/aflora.nsf>) The database of traditional plant utilization in Africa Center for African Area Studies, Kyoto University.

Ifeoma, O., Salawu, O. (2013). Screening of Herbal Medicines for Potential Toxicities. In: Pharmacology, Toxicology and Pharmaceutical Sciences. "New Insights into Toxicity and Drug Testing". Silvakumar Gowder ed. (www.intechopen.com/books/references/new-insight-into-toxicity-and-drug-testing/screening-of-herbal-medicines-for-potential-toxicities) Retrieved 15/2/2013

Jagtenberg, T., Evans, S., Grant, A., Howden, I., Lewis, M., Singer, J. (2006): "Evidence-based medicine and naturopathy". Journal of Alternative and Complementary Medicine **12**: 323–8

Jeruto, P., Lukhoba, C., Ouma, G., Mutai, C. and Otieno, D. (2008): An Ethnobotanical study of medicinal plants used by the Nandi people in Kenya. Journal of Ethnopharmacology. **116**: 370-376.

Jeruto, P., (2008): Ethnobotanical Survey, Phytochemical Analysis, Bioassay and

Propagation of some Medicinal Plants in Aldai Division of Nandi south District. Msc thesis, submitted to Maseno University.

Jeruto, P., Mutai, C., Catherine, L. and Ouma, G., (2011): Phytochemical constituents of some medicinal plants used by the Nandis of South Nandi district, Kenya. *Journal of Animal and Plant Sciences*, **9(3):**1201- 1210.

Johnson, C., Baird, R., Dougherty, P.E., Globe, G. Green, B.N., Haneline, M. Hawk, C. Injeyan, H. S. (2008): "Chiropractic and public health: current state and future vision". *Journal of manipulative and physiological therapeutics* **31:** 397-441

Kalyani, G. A. (1983): Experimental evaluation of anthelmintic and purgative activity of *Myrsine Africana* fruits. *Ancient Science of life*, **3:** 82-84

Kapil, A. (1998): Hospital acquired infections. *Tropical Gastroenterology*, **19:** 127-129.

Kapil, A. (2005). The challenges of antibiotic resistance; Need to contemplate. *Indian Journal of Medical Research* **121:** 183-191.

Kaplan, J. M, Goretski, S. A, Keith, S. Calford, L. (1990): Cost of antibiotic therapy for infants and children. *Pediatric Infectious Diseases Journal* **9:** 722-728.

Kaptchuk, T.J. Eisenberg, D.M. (1998): "Chiropractic: origins, controversies, and contributions". *Archives of Internal Medicine* **158:** 2215-2224.

Keating, J. C. (2005): "A brief history of the chiropractic profession". In Haldeman S,

Keating, J. C. Jr, Charlton KH, Grod JP, Perle SM, Sikorski D, Winterstein JF (2005): "Subluxation: dogma or science?" *Chiropractic Osteopathic* **13:** 17.
(<http://chiroandosteo.com/content/13/1/17>). Retrieved 29/11/2011

- Keriko, J.M., Nakajima, S., Baba, N., Isozaki, Y., Iwaso, J., (1995):** Growth regulators from Kenyan plant, *Psiada punctulata*. Scientific Reports of the Faculty of Agriculture Okayama University **84**: 7-11
- Khaleefathullah S. (2002):** Unani Medicine. In: Chaudhury Ranjit Roy, Rafei Uton Muchatar., editors. Traditional Medicine in Asia. New Delhi: WHO- Regional Office for South East Asia; pp. 31–46.
- Kiringe, J. W. (2006):** A Survey of Ethnomedicinal Health Remedies used by the Maasai of Southern Kajiado District, Kenya. Ethnobotany Research & Applications 4: 61-73
- Kisangau, D. P., Herbert, U. M. Lyaruu, K. , Hosla, U., Cosam, C. J.(2007):** Use of traditional medicine in the management of HIV/AIDS opportunistic infections in Tanzania: A case in the Bukoba rural districts. Journal of Ethnobiology and Ethnomedicine. **3**: 29
- Kleijnen, J; Knipschild, P; Ter Riet, G (1991):** "Clinical trials of homoeopathy", British Medical Journal **302**: 316–323,
- Ko, R. J. (1998):** Adulterants in Asian Patent Medicine. New England Journal of Medicine **339**: 847.
- Kokwaro, J. O., (1993):** Medicinal plants of East Africa, (2nd Edition), East African Literature bureau, Nairobi.
- Kunin, C. M., Tupasi T, Craig, W.A. (1973):** Use of antibiotics. A brief exposition of the problem and some tentative solutions. Annals of Internal Medicine **79**: 550-560.
- Kurup, P. N. V. (2004):** Ayurveda- A potential Global Medical system. In: Mishra, L. C., editor. Scientific Basis for Ayurvedic Therapies. New York: CRC Press; pp. 1–15.

Lai, P. K. and Roy, J. (2004): "Antimicrobial and chemopreventive properties of herbs and spices". *Current Medical Chemistry*. **11**: 1451–1460

Langley, S. (2007): "History of Naturopathy". Excerpt from *The Naturopathy Workbook*. UK: College of Natural Medicine. **11**: 1361–1370.

Levy, S. B. (2001): Antibacterial household products: cause for concern. *Emerging Infectious Diseases*. **7**: 512-515.

Linde, K; Clausius, N; Ramirez, G; Melchart, D; Eitel, F; Hedges, L; Jonas, W (1997): "Are the clinical effects of homoeopathy placebo effects? A meta-analysis of placebo-controlled trials", *The Lancet* **350**: 834-843.

Linde, K., Hondras, M., Vickers, A., Ter Riet, G. Melchart, D. (2001): "Systematic reviews of complementary therapies - an annotated bibliography. Part 3: Homeopathy". *BMC complementary and alternative medicine* **1**: 4

Linde, K.; Melchart, D. (1998): "Randomized Controlled Trials of Individualized Homeopathy: A State-of-the-Art Review", *The Journal of Alternative and Complementary Medicine* **4**: 371–388

Lorke, (1983). A new approach to practical Acute Toxicity testing. *Archives of toxicology* **53**: 275-287.

Maddox, J., Randi, J, Stewart, W. W. (1988): "High-dilution" experiments a delusion". *Nature* **334**: 287–290.

Mainen, J. M., Donald, F. O., Pamela, K. M. Anke, W. (2010): Ethnomedicine of the Kagera Region, north western Tanzania. Part 2: The medicinal plants used in Katoro Ward, Bukoba District. *Journal of Ethnobiology and Ethnomedicine*; **6**:19

- Mandal, P., Sinha Babu, S.P., Mandal, N.C. (2005):** Antimicrobial activity of Saponins from *Acacia auriculiformis*. *Fitoterapia*; **76**: 462-565.
- Manjunatha, B.K. (2006):** Antibacterial activity of *Pterocarpus santalinus*. *Indian Journal of Pharmaceutical Science*. **68**: 115-116
- Mariita, R.M. Ogol, P.O., Oguge, N.O., Okemo, P.O., (2011):** Methanol Extract of Three Medicinal Plants from Samburu in Northern Kenya Show Significant Antimycobacterial, Antibacterial and Antifungal Properties. *Research Journal of Medicinal Plants* **5**: 54-64
- Martin, M., Mathias, E. and McCorke, C.M. (2001):** Ethno veterinary medicine: an annotated bibliography of Community Animal Health Care. Intermediate Technology Development Group Publishing, London. 612 Pp.
- Martin, S. C. (1993):** "Chiropractic and the social context of medical technology, 1895-1925". *Technology and culture* **34**: 808–834.
- Martinez, M.C., Schmeiser, H. H. (2000):** Urolethelial carcinoma associated with the use of a Chinese herb (*Aristolochia fangchi*). *New English Journal of Medicine* **342**: 1686-1692.
- Pubmed**
- Mary-Ann, S., Anna-Barbara, M. (2006):** Sexually Transmitted Infections. Pp1-8 Internet Retrieved Nov. 11, 2009
- Mathie, R. (2003):**"The research evidence base for homeopathy: a fresh assessment of the literature", *Homeopathy* **92**: 84–91
- Matsumura F. (1975):** Toxicology of Insecticides 2nd edition Plenum Press N.Y. 1975 pg 4-6
- McCall, T. (2007):** Yoga as Medicine: the yogic prescription for health and healing: a yoga journal book, p. xvii. Bantam, New York.

McCorkle, C.M. (1995): ‘Back to the future: Lessons from Ethnoveterinary RD and E for Studying and Applying Local Knowledge’. *Agricultural and Human Values* 12, pp. 52-80.

McCorkle, C.M., Martin, M. (1998): Parallels and potentials in animal and human ethnomedical technique. *Agriculture and Human Values* **15**: 139–144.

McLaughlin, J. L. (1991). Crown gall tumors on potato discs and brine shrimp lethality: Two simple bioassays for higher plant screening and fractionation. *Methods Plant Biochem.* **6**: 1-32.

MacLaughlin JL, Chnag CJ, Smith DL (1991). “Bench-Top” Bioassays for the discovery of Bioactive Natural Product: An update (Atta Ur-Rahman Ed), *Studies in natural product Chemistry*. Elsevier Science Publisher B.V. Amsterdam. **9**: 388-409.

Meeker, W.C. Haldeman, S. (2002): "Chiropractic: a profession at the crossroads of mainstream and alternative medicine". *Annals of internal medicine* **136**: 216–27

Meyer, B. N., Ferrigni, N. R., Putman, J.E., Jacobson, L. B., Nichols, D.E., McLaughlin, J. L. (1982): Brineshrimp: A conventional general bioassay for active plants constituents; *Planta Medica* **45**: 31-34.

Midiwo J. O., Yenesew A, Juma Kerubo B.F., Omosa, L Omosa, I. L. and Mutisya D. (2002): Phytochemical Evaluation of Some Kenyan Medicinal Plants. *Phytochemistry Reviews* **1**:311-323.

<http://www.napreca.net/publications/11symposium/word/B-9-19Midiwo.doc>(Retrieved 12/3/2011)

- Miotti, P.G., Chiphangwi, J.D., Dallabetta, G.A. 1992):** Baillieres Clinical Obstetrics Gynecology **6**: 165-186
- Mohamed, A., Martina, W., Gudrun, S. Ulrike, L. (2007):** Antioxidant, antimicrobial and Cytotoxic activities of selected medicinal plants from Yemen. Journal of Ethnopharmacology, **111**: 657-666
- Mokaila, A. (2001):** "Traditional Versus Western Medicine-African Context". Drury University Springfield Missouri (<http://www.drury.edu/multinl/story.cfm?ID=2524&NLID=166>). Retrieved 11 March 2010
- Mongelli, E., Pomilio, A. B., Sanchez, J. B., Guerra, F. M., & Massanet, G. M. (2002).** ent-Kaur-16-en-19-oic acid, a KB cells cytotoxic diterpenoid from *Elaeoselinum foetidum*. Phytotherapy Research **16**: 387-388.
- Mootz, R. D., Shekelle, P. G. (1997):** "Content of practice". In Cherkin, D.C., Mootz, R.D. (eds.). Chiropractic in the United States: Training, Practice, and Research. Rockville, MD: Agency for Health Care Policy and Research. pp. 67–91. OCLC 39856366. <http://chiroweb.com/archives/ahcpr/chapter3.htm>. Retrieved 2008-10-10. AHCPR Pub No. 98-N002.
- Morris, C.A., Avorn, J. (2003):** Internet marketing of herbal products. Journal of American Medical Association; **290**:1505-9 Pubmed.
- Mosihuzzaman, M., Choudhary, M. I. Noller, B. N., Kumar, V., Lajis, N. H., Ali, L. (2008):** Protocols on safety, efficacy, standardization, and documentation of herbal medicine.

- 2008 International Union of Pure and Applied Chemistry (IUPAC) Technical report. Pure and Applied Chemistry; **80**: 2195-2230.
- Mosmann, T. (1983)**: Rapid calorimetric assay for cellular growth and survival: Application to proliferation and cytotoxicity assay. *Journal of immunology methods*; **65**: 55-63.
- Mu, L.H., Huang, Z. X., Liu, P., Hu, Y. (2011)**: Acute and Sub acute Toxicity Assessment of the Herbal formula Kai Xin San. *Journal of Ethnopharmacology* **138**: 351-357.
- Muregi, F.W., Ishih, A., Miyase, T., Suzuki, T., Kino, H. Amano, T., Mkoji G.M. and Terada, M. (2006)**: Antimalarial activity of methanolic extracts from plants used in Kenyan ethnomedicine and their interactions with chloroquine (CQ) against a CQ-tolerant rodent parasite, in mice. *Journal of Ethnopharmacology* **3**: 190-195
- Muthaura, C.N., Rukunga, G.M., Chhabra, S.C., Mungai, G.M., Njagi, E.N.M. (2007)**: Traditional antimalarial phytotherapy remedies used by the Kwale community of the Kenyan Coast. *Journal of Ethnopharmacology* **114** : 377-386
- Najma, D., Rukunga, G., Yenesew, A., Mbora, A., Mwaura, L., Dawson, I., Jamnadass, R. (2008)**. Common Antimalarial Trees and Shrubs of East Africa. A description of species and a guide to cultivation and conservation through use. ISBN. PP50-52
- Nanyingi, O. M., Mbaria, J. M., Ogara, W., Lanyasunya, A., Wagate and Munenge, H. (2008)**: Ethno pharmacological survey of Samburu District of Kenya. *Journal of Ethnobiology and Ethnomedicine*; **4**: 14
- Narayanaswamy, V. (1975)**: In: Introduction to the Siddha System of Medicine. T.

- Nagar, Madras (Chennai): Research Institute of Siddha Medicine.
- NCCLS, (2000):** National Committee for Clinical Laboratory Standards. Approved Standards M-100-S10: Performance Standard for antimicrobial susceptibility testing Wayne, Pennsylvania:
- Nguyen, Q. V. Eun, J. B., (2011):** Antioxidant activity of solvent extracts from Vietnamese medicinal plants. *Journal of Medicinal Plants Research*; **5(13):** 2798-2811
- Njoroge, G. N. and R. W. Bussman, (2006):** Traditional management of Ear , Nose and Tongue diseases in Central Kenya. *Journal of Ethnobiology and Ethnomedicine* **2:** 1-9
- Nelson, C.F., Lawrence, D.J., Triano, J.J. (2005):** "Chiropractic as spine care: a model for the profession". *Chiropractic Osteopathic* **13:** 9. <http://chiroandosteo.com/content/13/1/9>.
- Neyres Z. T. J., Iberê F. S. J., Joaquim C. S. L., Edson M. C. Domingos T. O. M. (2012):** Hippocratic screening and subchronic oral toxicity assessment of the methanol extract of *Vatairea macrocarpa* heartwood in rodents. *Revista Brasileira de Farmacognosia*. (<http://dx.doi.org/>) Retrieved 23/01/2013
- Nick, W. and Simon, G. M. (2006):** Plant use of the Maasai of Sekenani Valley, Maasai Mara Kenya. *Journal of Ethnobiology and Ethnomedicine*, **2:** 22.
- Norris W, Paredes A.H., Lewis J.H. (2008).** Drug-induced liver injury in 2007. *Curr Opin Gastroen* **24:** 287-297
- Obici, S., O tobone, F.J., da Silva Sela, V. R., Ishida, K., da, Silva, J. C. Nakamura, C. V. (2008):** Preliminary Toxicity Study of dichloromethane extract of *Kielmeyera coriacea* stems in mice and rats. *Journal of Ethnopharmacology*, **115:** 131-139.

- Odhiambo, J.A., Siboe, G.M., Lukhoba, C.W. and Dossaji, S.F. (2009):** Antifungal activity of crude extracts of selected medicinal plants used in combinations in Lake Victoria Basin, Kenya. *Plant Products Research Journal* **13**: 35-43
- OECD, 2001d:** Harmonized Integrated Classification System for Human Health and Environmental Hazards of Chemical Substances and Mixtures. Available from: <<http://www1.oecd.org/ehs/class/Harmonizedintegrated.pdf>> (Chapter 2.1). OECD, Paris.
- OECD, (1998):** The OECD guidelines for testing of chemicals 408. Subchronic oral toxicity-Rodent: 90 day study OECD Paris France.
- OECD, (2001a):** The OECD guideline for testing of chemicals 420. Acute oral toxicity fixed dose procedure. OECD Paris France.
- Olson, H., Betton, G. Robinson, D., Thomas, K., Monro, A., Kolaja, J. (2002):** Concordance of toxicity of pharmaceuticals in humans and in animals. *Regulatory Toxicology and Pharmacology* **32**: 56-67.
- Opal, S. M., Mayer, K. H., Medecros, A. A. (2000):** Mechanisms of Bacterial Resistance. In: Mandell, G. L., Bennetl, J.E., Dolin R, editors. Principles and practice of infectious diseases. 5th ed. Vol.II. New York, USA: Churchill Livingstone;p. 236-253.
- Orwa, C. A, Kindt, R., Jamnadass, R., Antony, S. (2009).** Agroforestry database: A tree reference and selection guide version 4.0 (<http://www.worldagroforestry.org>). 15/6/2014
- Oryemo, C., Ziraba, R. B., Odyek, O., Omagor, N., Opio, A. (2011):** Phytochemical properties and toxicity to brineshrimp of medicinal plants in Erute County, Lira district, Uganda. *Journal of Medical Plant Research*; **5**: 5450-5457.

Otieno, J.N., Hosea, K.M.M., Lyaruu, H.V., and Mahunnah, R.L.A. (2008): Multi-Plant or single extracts, which is the most effective for local healing in Tanzania? African Journal of Traditional, Complementary and Alternative Medicines Volume **5**: 165-172.

Papp, L. V., Lu, J., Holmgren, A. Khanna, K.K. (2007): "From selenium to selenoproteins: synthesis, identity, and their role in human health". Antioxidants & redox signaling **9 (7)**: 775–806

Parker, M.A.S., Chabot, B. J., Ward, T. J. (2007): Traditional dietary additives of the Maasai are antiviral against Measles virus. *Journal of Ethnopharmacology*. **114**: 146-152

Parliament of New South Wales.(2005): Final Report, Report into Traditional Chinese Medicine
(<http://www.parliament.nsw.gov.au/prod/parlment/committee.nsf/FILE/reportversion2.pdf>)
f). Retrieved 2010-11-03.

Peteros, N. P. Mylene, M. (2010): Antioxidant and cytotoxic activities and phytochemical screening of four Philippine medicinal plants. *Journal of Medical Plants Research*; **4**: 407-414.

Peter, W. T. (2010): Kenya country report on reproductive health and reproductive Rights. Emphasis on HIV/AIDS. National Council for Population & Development Nairobi, Kenya

Pieroni, A., Quave, C., Heinrich, M., (2002): Ethnopharmacy of the Ethnic Albanians Ebereshe of Northern Basilicata, Italy. *Fitoterapia*; **73**: 217-241

- Pisutthanan, S., Plianbangchang, P., Ruanruay, S., Muanrit, O. (2004):** Brineshrimp Lethality activity of Thai Medicinal Plants in the Family *Meliaceae*. Naresuan University Journal; **12:** 13-18
- Prasad, L. V. (2002):** In: Indian System of Medicine and Homoeopathy Traditional Medicine in Asia. Chaudhury Ranjit Roy, Rafei Uton Muchatar., editors. New Delhi: WHO- Regional Office for South East Asia; pp. 283–286.
- Prescott, M. L., John, P., Harley, D., Klein, A., (1999):** Antimicrobial chemotherapy. Microbiology 2nd edition, pp 328 edited by C. Brown.
- Prophet, E. P., Mills Arrington, J. B., Sobin, L. H., (1994).** Laboratory methods in Histotechnology. American Registry of Pathology Washington DC. ISBN:
- Rang, H., Dale. M. M. (1987):** Pharmacology. Churchil Livingstone. Edinburgh.
- Redwood, D., Hawk, C., Cambron, J., Vinjamury S.P., Bedard, J. (2008):** "Do chiropractors identify with complementary and alternative medicine? Results of a survey". Journal of Alternative and Complementary Medicine **14:** 361–368.
- Rhiou, H., El Hilaly, J., Israili, J. H., Lyoussi, B., (2008):** Acute and subacute toxicity of an aqueous extract of *Herniaria grabia* in rodents. Journal of Ethnopharmacology; **118:** 378-386.
- Rice, L. B., Bonomo, R. A. (1996):** Genetic and biochemical mechanisms of bacterial resistance to antimicrobial agents. In: Lorian V, editor. Antibiotics in laboratory medicine. 4th ed Baltimore, USA: Willims & Wilkins, p. 453-501.
- Richard P., (1990):** An Introduction to the Medical History of Ethiopia (Trenton: Red Sea Press, pp. 76, 91

Rieser, M. J., Gu, Z.-M., Fang, X.-P., Zeng, L., Wood, K. V., McLaughlin, J. L. (1996): Five novel mono-tetrahydrofuran ring acetogenins from the seeds of *Annona muricata*. *Journal of Natural Products*; 59: 100-108.

Riviere, C., Van Nguyen, T. H., Pieters, L., Dejaegher, B., Heyden, Y. V., Murih, C. V., Quetin Leclercq, J., (2009): Polyphenols isolated from antiradical extracts of *Mallotus metcalfianus*. *Phytochemistry* **70**: 86-94.

Roberts, M.F, Wink, M. (1998): Alkaloids: biochemistry, ecology, and medicinal applications. Library of Congress Cataloguing- in- Publication data

Ronald, A. R., Michelle,, J. A. (2007). Microbiology of the Genitourinary system. Bookshelf I. D: (NBK8136 (www.ncbi.nlm.nih.gov/books/NBK8135/))

Ronald, M. Torgeson, D.T. (1998): What are pragmatic trials? *British Medical Journal*. 3160-285. Pubmed.

Rubber, M. J., Kanfer, I. (2004): HPLC chromatographic determination of selected flavonols in *Gingko biloba* oral dosage forms. *Journal of pharmaceutical science* **7**: 303-9. Pubmed.

Santos, S. R., Rangle, E. T., Lima, J.C.S., Silva, R. M., Lopes, L., Noldin, V. F., Cechinel, F. V., Delle, M., Martin, D. T.O., (2009): Toxicological and Phytochemical studies of *Aspidosperma subincanum* Mart. Stem bark (Guatambu). *Pharmazie*; **64**:1-4.

Scalbert, A., C. Manach, C. Morand, C. Remesy and L.Jimenez. (2005): Dietary Polyphenols and the prevention of diseases. *Critical Review in Food Science and Nutrition* **45**: 287-306

- Scheld, .W. M. (2003).** Maintaining Fluoroquinolone class efficacy. Review of influencing factors. *Journal of Emerging Infectious Diseases* **9**: 1-9.
- Schleide, E., Mischke, U., Roll, R., Kayser, D., (1992):** A national validation study of the acute-toxic-class method—an alternative to the LD50 test. *Archives of Toxicology* **66**: 455–470.
- Schleide, E., Mischke, U., Diener, W., Kayser, D., (1995):** The international validation study of the acute toxic class method (oral). *Archives of Toxicology* **69**: 659–670.
- Schneider, G. and J. Wolfling. (2004):** Synthetic Cardenolides and related compounds. *Current Organic Chemistry* **8** No. 14.
- Shahidi, B. H. (2004):** Evaluation of antimicrobial properties of Iranian medicinal plants against *Micrococcus luteus*, *Serratia marcescens*, *Klebsiella pneumonia* and *Bordetella bronchoseptica*. *Asian journal of plant sciences*; **3**: 82-86.
- Shang, A., Huwiler-Müntener, K., Nartey, L., Jüni, P., Dörig, S., Sterne, J. A. C., Pewsner, D., Egger, M. (2005):** "Are the clinical effects of homoeopathy placebo effects? Comparative study of placebo-controlled trials of homoeopathy and allopathy", *The Lancet* **366**: 726–732,
- Shrivastava, N. Patel, T. (2007):** *Clerodendrum* and Healthcare: An overview. *Medicinal and aromatic plant science and biotechnology* **1**:142-150.
- Shukla, N. Poles, M. (2004):** Hepatitis B virus infection: Coinfection with Hepatitis C virus, Hepatitis D virus and Human Immunodeficiency virus. *Clinical Liver Disease* **8(2)**: 445-60.
- Signore, A. (2013):** "About inflammation and infection". *EJNMMI Research* **8(3)**:

Sileshi, A., Gebre-Mariam, T., Asres, K. (2007): Antibacterial and Antifungal Activities of Extracts of Some Medicinal Plants of Ethiopia. *Ethiopian Pharmaceutical Journal* **25:**111-120

Singh and Ernst, (2008): Trick or treatment 70-73 (Wikipedia)
<http://books.google.com/books?>(Retrieved 13/4/2010)

Smith-Palmer, A., Stewart, J. and Fyfe, L. (1998): Antimicrobial properties of plant essential oils and essences against five important food-borne pathogens. *Letters in Applied Microbiology* **26:** 118-122

Sofowara, A. (1982). Medicinal plants and traditional medicine in Africa. John Wiley and sons Ltd Nigeria. Pp 33-34.

Solis, P. N., Wright, C. W., Anderson, M. M., Gupta, M. P., & Phillipson, J. D.(1993): A microwell cytotoxicity assay using *Artemia salina* (brine shrimp). *Planta Medica*, **59:** 250-252.

Stermitz, F. R., Lorez, P., Tawara, J.N., Zenewiz, L. A., and Lewis, K. (2002): Synergy in a medicinal plant: Antimicrobial action of Berberine potentiated by 5-methoxyhydrocarpin, a multidrug pump inhibitor. *PNAS* **97:** 1433-1437.
http://www.conserveafrica.org.uk/medicinal_plants.pdf. "Medicinal Plants and Natural products". Conserve Africa. Conserve Africa Foundation. Retrieved 4 February 2010.

Stickel, F., Patsenker, E., Schuppan, D., (2005): Herbal hepatotoxicity. *Journal of Hepatology*; **43:** 901-10.

- Straight, B. (2005):** Cutting Time: Beads, Sex, and Songs in the Making of Samburu Memory.
In: The Qualities of Time: Temporal Dimensions of Social Form and Human Experience.
Wendy J. and David M. (eds.). ASA Monograph Series, Berg Pp. 267-283
- Suffredini, I., Mateus, P., Nepomoceno, D., Younes, R., and Varella, A. (2006):** Antibacterial and cytotoxic activity of Brazilian plant extract Clusiaceae. *Memorias do Instituto Oswaldo Cruz*; **101**: 287-290.
- Talalay, P. Talalay, P. (2001):** The importance of using scientific principles in the development of medicinal agents from plants. *Academic. Medicine* **76**: 233-247.
- Taylor, L. (2004):** The healing power of rain forest herbs. www.raintree.com/prepmethodd.htm,
- Telam T., (2007):** Ethnobotanical Survey of medicinal plants used by people in Zigie Peninsula North West Ethiopia. *Journal of Ethnobiology and Ethnomedicine* **3**:12
- Teo, S., Stirling, D., Thomas, S., Hoberman, A., Kiorpes, A., Khetani, V. (2008):** A 90 day oral gavage toxicity study of O, L-methyl phenidate in Sprague – Dawley rats. *Toxicology*, **179**: 183-196
- Teshome, N., Negussu, M., Kelbessa, U.(2004):** Diuretic effects of crude Extracts of *Carissa edulis* in rats. *Journal of Ethnopharmacology* **95**: 57-61.
- Tihalum, T., Minitse G. M., Yalemtehay, M. (2007):** Knowledge and use of Medicinal Plants by the people around Debre Libanos Monastery in Ethiopia. *Journal of Ehnopharmacology* **11**:271-283

Tlili, N. ., Khaldi, A., Triki, S., Munne-Bosch, S. (2010): Phenolic compounds and Vitamin antioxidants of Caper (*Capparis spinosa*). *Plants Food for Human Nutrition*. Internet Retrieved sept 2010

Trease, G.E.; Evans, W.C., (1989). A Text book of pharmacognosy. Academic press, London. Pp 22-40

Trease, G.E; Evans, W. C. (1999). Pharmacognosy, edt Evans W. L. 14TH edition London W. B. Saunders company Ltd, pp 109- 334.

Tyler V. E. and S. Foster, (1999): Honest Herbal revised. edition. The Physicians' Desk Tyler's Reference for Herbal Medicines (annual). Retrieved 20/6/2010

Udem, S.C., Ezeasor, C.K. (2010). The acute and subchronic toxicity studies of aqueous leaf and stem bark extract of *Costus afer ker* (Zingiberaceae) in mice. *Complementary Clinical Pathoogyl* **19**: 75-80.

UNAIDS, WHO (2007). "2007 AIDS epidemic update" <http://data.unaids.org/pub>. (Retrieved 2011-03-12.

UNCTAD (United Nations Conference on Trade and Development): (2000): Systems and National Experiences for Protecting Traditional Knowledge, Innovations and Practices. In: *Background Note by the UNCTAD Secretariat*. Geneva, United Nations Conference on Trade and Development; 2000. Document reference TD/B/COM.1/EM.13/2

users.ipfw.edu/blumenth/pharmweb/antibiotics.pdf (retrieved 15/2/2013)

US: office of the inspector general, HHS (2001): Adverse effect event reporting for dietary supplement: An inadequate safety value in marketing herbal remedies there maybe illegal claims, treatment, prevention, diagnosis, false information on herb performance and flawed methodologies used.

Verlag, G. T. (2005). Medical Microbiology. Stuttgart: George Thieme Verlag. Pp398.

Verma, U., Sharma, R., Gupta, P., Gupta, S., Kapoor, B.(2007): Allopathic versus ayurvedic practices in tertiary care institutes of urban North India. Indian Journal of Pharmacology **39:52-54.**

Villanueva-Russell Y (2005): "Evidence-based medicine and its implications for the profession of chiropractic". Society of Scientific Medicine **60: 545–561**

Virus pathogenesis Microbiology bytes. Wikipedia (Retrieved 20/2/2013)

Wahlberg, A (2007): "A quackery with a difference. New medical pluralism and the problem of 'dangerous practitioners' in the United Kingdom", Social Science and Medicine **65: 2307–2316,**

Wengell, D., Gabriel, N. (2008): Educational Opportunities in Integrative Medicine. Atlanta: Hunter Press. p. 198. <http://books=homeopathy+suppression> (Retrieved 2 8/2010)

WHO (1998): Report, Technical Briefing on Traditional Medicine. In Forty-ninth Regional Committee Meeting, Manila, Philippines, 18 September 1998. Manila, WHO Regional Office for the Western Pacific.

WHO (1999) a: Consultation Meeting on Traditional Medicine and Modern Medicine,

Harmonizing the Two Approaches. Geneva,

WHO (1999) b: Traditional, Complementary and Alternative Medicines and Therapies.

Washington DC, WHO Regional Office for the Americas/Pan American Health Organization/World Health Organization (Working group OPS/OMS).

WHO (2000). General Guidelines for methodologies on Research and Evaluation of Traditional Medicine. World Health Organisation, Geneva Switzerland. WHO/EDM/TRM/2000.1 pp80.

WHO (2001 a): 'Global Prevalence and Incidence of Selected Curable Sexually Transmitted Infections Overview and Estimates 2001

WHO (2001) b: "Legal Status of Traditional Medicine and Complementary/Alternative Medicine: A Worldwide Review". <http://whqlibdoc.who.int/hq/2001/WHO>. Retrieved 2011-09-12.

WHO, (2002): WHO Traditional Medicine Strategy 2002-2005. World Health Organization, Geneva.

WHO, (2005): WHO guidelines on basic training and safety in chiropractic. ISBN 92-4-159371-7. <http://www.who.int/medicines/areas/traditional/Chiro-Guidelines.pdf>. Retrieved 2008-02-29.

WHO, (2007): Sexually transmitted infections fact sheet Geneva, World Health Organization.

WHO, (2010): Initiative for Vaccine Research. "Staphylococcal infection" .

Whorton, J. C. (2004): Oxford University Press US. ed. Nature Cures: The History of
Alternative

Wikipedia (en.wikipedia.org/wiki/nilotic-people) (Retrieved 6/3/2013)

Wikipedia (en.wikipedia.org/wiki/Sansevieria)(Retrieved 3/5/2011)

William, R. (2000): Antimicrobial resistance a global threat. Essential Drug Monitor; **1**: 8-29.

Willis, C., Booth, H., Westacott, S., Hawtin, P. (1999): Detection of antimicrobial agents in
warm water prawns. Communicable Diseases Public Health; **2**: 210-14

Willis, C. (2000): Antibiotics in the food chain: their impact on the consumer. Review
of Medical Microbiology; **11** : 153-160

Wonder, K. M., Abotsi, George, K., Ainooson, E.B.G. (2011): Acute and Sub acute toxicity
studies of Ethanolic extract of the aerial parts of *Hillieria latifolia* (Lam) H. Walt.
(*Phytolaccaceae*) in Rodents. West African Journal of Pharmacy, **22(1)**: 27-35.

www.agritech.tnau.ac.in/extraction_technologies. (Retrieved 21/5/2014)

www.fao.org (Retrieved 4/4/2010).

www.herbnet.com/herb%20_ABhtm (internet)(Retrieved 7/7/2012)

www.magical.kenya.com (internet) retrieved 15/2/2013.

www.metafro.be/prelude/view-reference (internet) Retrieved 18/9/ 2010

www.motherearthliving.com/health-wellness/herbal-extract.aspx (retrieved 21/5/2014)

www.naturalhealthschool.com/prepper-lesson-2-supplement.html. Retrieved on 10/3/2013

www.pc.maricopa.edu/Bioloc (retrieved 15/2/2013)

www.philadelphia.edu.jo/academics/sextraction. (Retrieved 21/5/2014).

www.who.int/drugresistance/documents/surveillancereport/en/ (2014). Antimicrobial resistance

Global report on surveillance.

www.who.int/mediacentre/factsheets/fs194/en/ (Retrieved on 13/6/2014)

www.yale.edu/africanow/1.1/article.1.4 (2006). The Yale Undergraduate Journal of African

Affairs 1:1Retrieved 13/6/2014

Xinrong, Y., Encyclopedic Reference of Traditional Chinese Medicine, p.8, (Wikipedia)

Retrieved 23/8/2010

Yineger, H. and Yewhalaw, D. (2007). Traditional medicinal plant knowledge and use

by local healers in Sekoru District, Jimma Zone, Southwestern Ethiopia. Journal of Ethnobiology and Ethnomedicine. **3**: 24

Yineger, H., Yewhalaw, D., Teketay, D. (2008): Ethnomedicinal plant knowledge and Practice

of the Oromo ethnic group in southwestern Ethiopia. Journal of Ethnobiology and Ethnomedicine, **4**:11

Yoney, A., Prieto, J. M., Lardos, A., Heinrich, M., (2010): Ethnopharmacy of the Turkish

speaking Cypriots in the Greater London. Phytotherapy Research **24**: 731-740.

Zabta, S.S., Khan AA, Nakaike, T.P. (2003): Medicinal plants and other useful plants of the

district SWAT Pakistan. p. 79.

Zhao, G., Hui, Y., Rupprecht, J. K., McLaughlin, J. L., & Wood, K. V. (1992): Additional bioactive compounds and trilobacin, a novel highly cytotoxic acetogenin, from the bark of *Asimina triloba*. *Journal of Natural Products* **55**: 347-356.

Zhong H. B. C. (1985): State administration of traditional Chinese medicine of the People's Republic of China. Shanghai Science and Technology Press: Shanghai. **3**: p. 245.

Zhou, H, J, R., Kang, J., Huang, X. L. Y., Zhuang, C., Y., F., Zhang, L., F., Z., Wu, T., Wu, X. (2010): Anti inflammatory effects of Caper (*Capparis spinosa*) fruit, aqueous extract and isolation of main phytochemicals. *Journal of Agriculture and Food Chemistry*.**2010**: 11-24

APPENDICES

Appendix 1: THE HERBALISTS WHO WERE INVOLVED IN THE STUDY AT SAMBURU COUNTY

Name of Respondent	Age group	Gender	Education background
Daudi	>57yrs	Male	Adult education
Barnabus	28-37yrs	Male	Secondary School
Amayiok	38-47yrs	Male	No formal education
Daniel	>57yrs	Male	Primary School
Sebastian	48-57yrs	Male	Adult education
Jennifer	48-57yrs	Female	Adult education
Ekuwan	28-37yrs	Male	Adult education
Miriam	28-37yrs	Female	Adult education
Apilia	28-37yrs	Female	No formal education
Mary	48-57yrs	Female	No formal education
Kebo	>57yrs	Female	No formal education
Ntilapan	>57yrs	Female	No formal education
Annah	>57yrs	Female	No formal education
Korete	> 57yrs	Female	No formal education
David	48-57yrs	Male	Primary School
Saimon	48-57yrs	Male	No formal education
Lorengana	48-57yrs	Female	Adult education
Salome	>57yrs	Female	No formal education
Francis	48-57yrs	Male	Primary School
Atobe	48-57yrs	Female	No formal education
Isaac Juma	48-57yrs	Male	Primary School
Lptapayion	>57yrs	Male	Primary School
Loison	38-47yrs	Male	No formal education
Saitoti	18-27yrs	Male	Secondary School
Philip	48-57yrs	Male	Secondary School

Leaduma Lomukuny Chaina	48-57 yrs >57yrs >57yrs	Male Male Male	No formal education No formal education No formal education
-------------------------------	-------------------------------	----------------------	---

Appendix 2: RESPONDENTS CONSENT AGREEMENT
ETHNOBOTANICAL SURVEY OF PLANTS USED IN THE
MANAGEMENT/TREATMENT OF REPRODUCTIVE DISEASES
AMONG THE SAMBURU COMMUNITY.

This is a study being carried out by Dr. Kamanja a student from the University of Nairobi Department of Public Health Pharmacology and Toxicology, on the plants of medicinal value used in the treatment of venereal diseases among the Samburu community:

RESPONDENTS CONSENT AGREEMENT

I.....hereby agree to participate in this study with my full consent and conscious and declare that to the best of my knowledge the information that I have provided is true, accurate and complete.

Signature/Thumb print.....Date.....

RESEARCHER'S DECLARATION

1. The following research will be undertaken with respect to the indigenous knowledge and intellectual proprietary of the herbal practioners.
2. We will at no given time initiate or conduct practices that are deemed to obtain information from the respondents by intimidation, coercion or false pretence.
3. The respondents will be informed of the intended project prior to questionnaire administration and in confidence to eliminate any degree of conspiracy.
4. We will be under no obligation to edit or tamper with the information provided by the respondents.
5. The information collected will be used for the described research purpose and not any undisclosed intentions

Appendix 3:SEMI STRUCTURED QUESTIONNAIRE

**ETHNOBOTANICAL SURVEY OF PLANTS USED IN THE
MANAGEMENT/TREATMENT OF REPRODUCTIVE DISEASES
AMONG THE SAMBURU COMMUNITY.**

This is a study being carried out by Dr. Kamanja a student from the University of Nairobi Department of Public Health Pharmacology and Toxicology, on the plants of medicinal value used in the treatment of Sexually Transmitted Diseases among the Samburu community:

NAME OF INTERVIEWER.....QUESTIONNAIRE

No.....

DATE...../...../2009

SECTION A: DEMOGRAPHIC DATA

1. Name of respondent:

2. Place/Location of practice

Division.....Location.....Sublocation.....Village.

3. Age:

Below 18 yrs

(1) 18 – 27 yrs

(2) 28 – 37 yrs

(3) 38 – 47 yrs

(4) 48 – 57 yrs

(6) Above 57 yrs (Tick as appropriate)

3. Gender

(1) Male

(2) Female (Tick as appropriate)

4. Marital Status (1) Married

(2) Single (never married)

(3) Separated/Divorced

(4) Widowed

5. Level of education (1) Never attended school

(2) Primary: Class.....

(3) Secondary: Form.....

(4) College/Polytechnic /University

(5) Others.....

6. Do you belong to any organization? Yes

No

Name of the Organization.....

7. How long have you been practicing as an herbalist?

- (1) 2 or less years
- (2) 2 -5 years
- (3) 5 – 10 years
- (4) Over 10 years

8. How did you acquire your skills?.....

SECTION B: DISEASE MANAGEMENT

1. Please give the five most common diseases that you treat

- a. _____ b. _____ c. _____ d. _____ e. _____

3. Which venereal diseases do you treat?.....

4. What signs do you use to determine venereal diseases?

5. How many cases of gonorrhoea have you treated in the last?

- a. One month
- b. Six months
- c. year

6. When was the last time you treated gonorrhoea?

7. Name the plants you use to treat gonorrhoea.

- a..... b..... c..... d.....
- e..... f..... g..... h.....

8. Please name three most commonly used plant used to treat gonorrhoea.

9. How common is the plant?

- a. Abundant
- b. Scarce
- c. Endangered

10. How do you prepare a single dose for a patient for each of the plants mentioned in 8 above?

Please follow the table below.

Name of plant	Source: wild, Lowland, Highland cultivated	Parts used: root, leaves, bark	Vehicle mixed with: water, soup, fat, oil honey	One dose preparation/administration

SECTION C: MEDICINAL PLANTS

- 1. Other than gonorrhoea list other diseases that are treated using these plants.....
.....
- 2. Is there a problem if the patient takes too much medicine?
 - a. Yes
 - b. No
- 3. a. If yes what happens to the patient?.....
b. In case this happens what do you do?.....
c. How do you treat the patient in case of overdose?.....
.....
- 4 How long does your preparation last?
.....
- 5. Do you use single plants or a mixture?.....
- 6. If mixed which plants?.....
- 7. Which plant/plants cause problems? Please name them in order of priority.....
.....
- 8. Are there patients referred to you from hospital?
Yes/No.....
If yes how many cases per month?.....

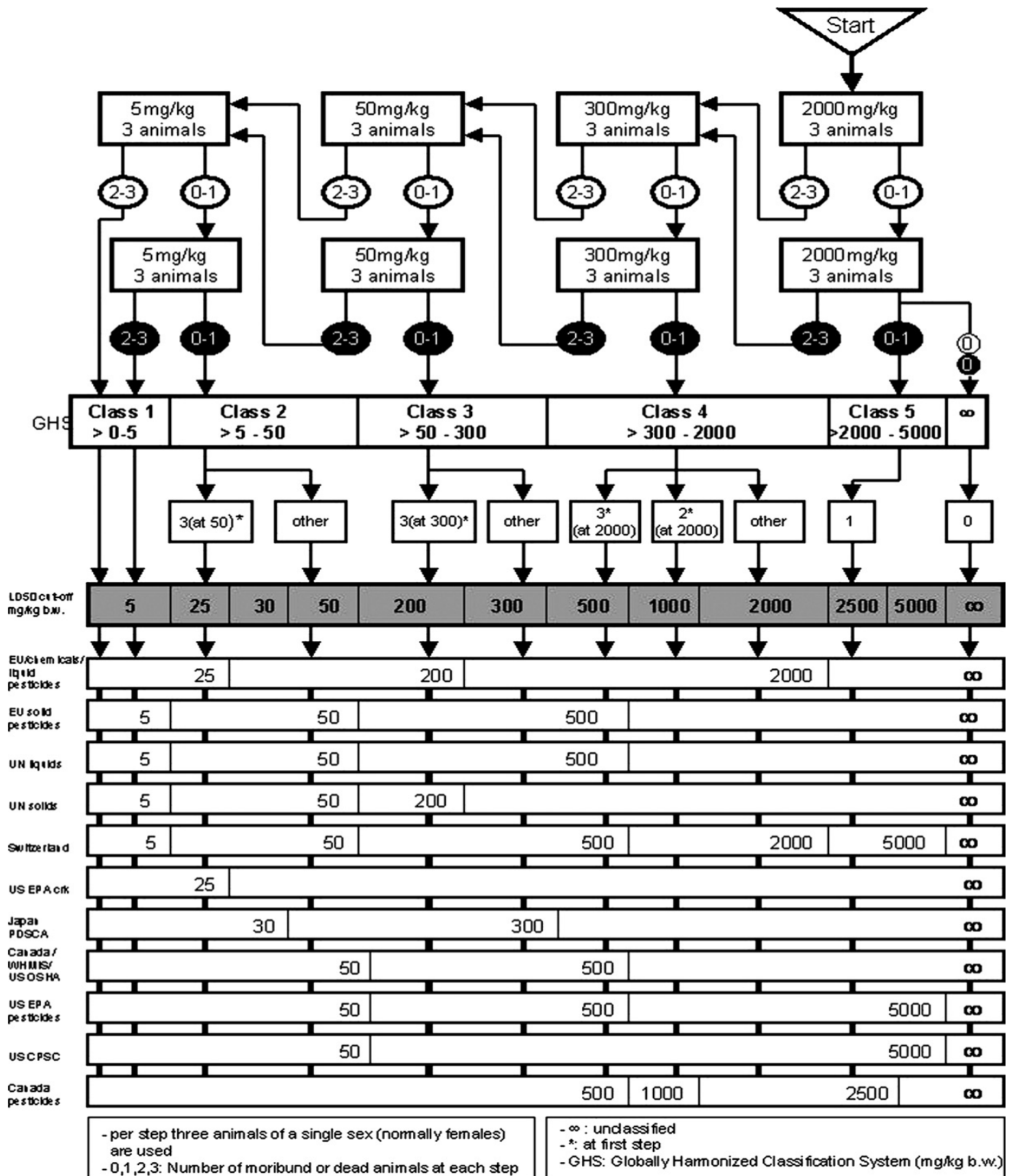

Appendix 4: Classification according to currently existing schemes to cover the transition period until full implementation of the GHS. (ATC METHOD)(OECD guideline 423 2001d)

Appendix 5: Table 3.1: Plants used in the management of sexually transmitted diseases by the Samburu traditional healers

FAMILY	BOTANICAL NAME & VOUCHER No.	SAMBURU NAME	HABIT (PART USED)	FORMULATION	MEDICINAL USE	% (n)	VEHICLES USED
Verbenaceae	<i>Clerodendrum myricoides</i> (Hoechst) Vatke Sp6	Lmakutikuti	Trees (roots)	A 3 finger thick root that is palm length is boiled in 1 litre of water for 15 minutes, sieved and cooled, 200mls is taken orally b.i.d for 3days; Roots are dried and the back removed and powdered 3 spoonfuls are then boiled in 1L water for 10-15 minutes, 200mls is taken orally twice a day for 3 days, For chronic cases 200mls is administered per rectum instilled with the patient held upside down for 3 minutes.	STIs, infertility, urethritis, arthritis, malaria flu, pneumonia, lack of libido	93 (27)	water, fat blood, milk' soup, soap
Apocynaceae	<i>Carissa edulis</i> Forsk (Vahl) Sp1	Lamuriai	Shrub (roots, fruits)	A 3-5 finger thick root which is palm length is boiled for 15 minutes in 2 liters of water. 400mls is taken daily for 5-7 days	Flu, STIs infertility pneumonia	52 (15)	water, soup milk, fat blood
Myrsinaceae	<i>Myrsine africana</i> L. Sp 2	Seketet	Shrub (seeds)	A handful of seeds are ground into powder and boiled in 200mls of water. This is taken twice a day for 5-7 days.	Flu, STIs helminthosis, cysticercosis lack of libido	31 (9)	Water, fat, soup milk

Cassia	<i>Acassia tortilis</i> (Forssk) Hayne Sp 8	Ltepes	Tree (bark)	A 3 finger size bark which is palm length is boiled in 1 liter of water for 20 minutes. 500mls is taken per day for 3 days. This is repeated after one week.	arthritis, injuries infertility, arthritis, migraine	21 (6)	water, soup
Compositae	<i>Psiada arabica</i> Jabb and Spach	Labai	Tree (roots, leaves)	A 2 finger thick root which is half hand long is cut into pieces mixed with 2 spoons of <i>Clerodendrum myricoides</i> powder and boiled in 1.5 liters of water for 6 minutes. 200mls is taken once daily for 5 days.	Acaricide, STIs	10 (3)	Water
Agavaceae	<i>Sansevierra enhribergii</i> Bach Sp 7	Ldupai	Shrub (root)	A 2 finger thick root or shoot which is palm length is boiled in half liter of water for 15 minutes. 200mls is taken daily for 7 days	STIs, Infertility, chest pains	10 (3)	Water, Fat
Rhamnaceae	<i>Rhamnus prinoides</i> Lherit Sp 3	Lkinyil	Shrub (roots, bark)	A 2 finger thick root or shoot which is palm length is boiled in half liter of water for 15 minutes. 200mls is taken daily for 7 days	Infertility, malaria, STIs arthritis	7 (2)	Water, Soup, Milk
Rhamnaceae	<i>Rhamnus staddo</i> A. Rich Sp 4	Lkukulai	Shrub (leaves, seeds)	A 2 finger thick root which is half hand long is cut into pieces and boiled in 1.5 liters of water for 6 minutes. 200mls is taken once daily for 5 days.	STIs, asthma, infertility, malaria, diabetes	24 (7)	Water, Milk
Ebenaceae	<i>Euclea</i>	Lchingei	Shrub	A 3 finger thick dried root is	STIs	3	Water,

	<i>divinorum</i>		(roots)	boiled in 400mls of water for 15 minutes. 200mls is taken once	infertility typhoid wounds	(1)	Soup, milk
Capparidaceae	<i>Capparis spinosa</i> L Sp11	Larkiringai	Shrub (roots, leaves)	A 3 finger size root which is palm length is boiled in 400mls of water for 15 minutes and 200mls is taken twice a day for 7 days	STIs, infertility, malaria fevers colds and flu	7 (2)	Water, Soup, Milk
Anarcadiaceae	<i>Rhus natalensis</i> Bernh.exKraus	Lmisigiyo	Herb (roots, leaves)	4 roots which are palm length or a handful of leaves are boiled in 400 mls of water. After cooling 200mls is taken twice daily for 5 days.	STIs infertility	3 (1)	Water, Milk
Vitaceae	<i>Hilderbrandtia sepalosa</i>	Lnyirman	Shrub (roots)	The back of the root is ground and 4 spoonfuls of powder are taken and boiled in 1liter of water or soaked overnight. 400mls is taken once.	STIs infertility malaria arthritis body aches	7 (2)	Water, Soup
Mimocaceae	<i>Acacia drepanolobium</i>	Rangau	Tree (bark)	3 pieces of bark 2feet long are soaked in 1 liter of water for half an hour. 200mls is taken daily for 5 days.	STIs infertility Arthritis	10 (3)	Water, Milk
Tiliaceae	<i>Grewia simi</i> L Sp 14	Lngalaiyoi		A palm length root is boiled with 4 liters of water. This is mixed with ruminal contents, soup and blood. 4 liters are taken.	STIs infertility stomach problems	3 (1)	Water, Soup
Euphorbiaceae	<i>Euphorbia candelabrum</i>	Mpopongi	Tree (branches Roots)	A 6cm branch is roasted until its liquid it is then dried and put in soup. This is boiled for 5 minutes and taken.	STIs infertility, asthma backache	3 (1)	Soup
Simarubarceae	<i>Harrisonia abyssinica</i>	Lasaramai		1 palm length root is taken and put in water and boiled then cooled and honey is added. A quarter of a glass is taken for 3 days	STIs, infertility arthritis, chest pains	3 (1)	Water, Honey

Appendix 6:

Table 3.2 Plants used in Samburu County and their published data on their ethnomedical uses

scientific name	Published data on ethnomedical uses	Uses according to Samburu traditional healers.
<i>Clerodendrum myricoides</i>	Venereal diseases (Kiringe et al.,2006 Nanyingi <i>et al.</i> , 2008), infertility (Njoroge and Bussman, 2006), antibacterial, antifungal activity (Yinegar <i>et al.</i> , 2008), Malaria (Muregi <i>et al.</i> , 2006 , Jeruto <i>et al.</i> , 2008), epilepsy, arthritis, malaria, diabetes, typhoid,cough/cold, eye problems, proper position of fetus,tonsillitis, rheumatism, gonorrhoea, East Coast Fever (Jeruto, 2008 Kalyani, 1983) treats abdominal colics,febrile convulsions (Mainen et al., 2010)	STIs, infertility, urethritis, arthritis, Malaria, flu, pneumonia, lack of libido
<i>Carissa edulis</i>	Used in venereal disease treatment (Kiringe <i>et al.</i> , 2006, Ichikawa, 1998), is used for the treatment of headache, chest complaints, rheumatism, gonorrhoea, syphilis, rabies and as a diuretic (Teshome <i>et al.</i> , 2004),	STIs infertility flu pneumonia

)	
<i>Rhamnus staddo</i>	Treats venereal diseases (Kiringe <i>et al.</i> , 2006, Ichikawa, 1998), has antifungal activity in combination with other medicinal plants (Odhiambo <i>et al.</i> , 2009), has antimalarial activity (Muthaura <i>et al.</i> , 2007)	STIs, infertility, malaria diabetes asthma
<i>Rhamnus prinoides</i>	Used in treatment of psychosis, enema, intestinal parasitism (Baerts and Lehman, 1989), treats rheumatism, (Kokwaro, 1993), is an antimalarial (Muthaura <i>et al.</i> , 2007, Jeruto <i>et al.</i> , 2008), used for colds tonsils, chest pains (Muregi <i>et al.</i> , 2006), Used for treatment of measles (Parker <i>et al.</i> , 2007) used as ointment for eczema and snakebites (Tilam. 2007, Tihalum <i>et al.</i> , 2007), treats venereal diseases, pneumonias arthritis, brucellosis, stomach ache (Ichikawa, 1998)	STIs, infertility, ,malaria, arthritis
<i>Sansevierria enhribergii</i>	used as antiseptic and as a bandage Treats gonorrhoea (Mohammed <i>et al.</i> , 2007), has antifungal activity (Keriko <i>et al.</i> , 1995)	STIs, infertility chest pains

<i>Myrsine africana</i> L.	Its used as an anthelmintic (Sileshi <i>et al.</i> , 2007, Gathuma <i>et al.</i> , 2004, Otieno <i>et al.</i> , 2008). Used to treat malaria wounds, gastrointestinal complications (Otieno <i>et al.</i> , 2008), It has antifertility, antinflammatory, analgesic antibacterial antitumor activities (Nanyingi <i>et al.</i> , 2008)	Flu, helminthosis ,cysticercosis improve libido arthritis, injuries
<i>Acacia tortilis</i> (Forsk)	Used in treatment of asthma (Hagos <i>et al.</i> , 1987). It is used for treatment of diarrhea, wound healing and as anthelmintic Treats venereal diseases (Ichikawa, 1998)	STIs, infertility ,arthritis, Migraine
<i>Psiadia Arabica</i> Jaub and Spach	Used to treat fevers colds abdominal pain, used as an acaricide in livestock (Bernard <i>et al.</i> , 2001, Otieno <i>et al.</i> , 2008)	Acaricide, sexually transmitted diseases
<i>Rhus natalensis</i>	roots used for treatment of venereal diseases, heartburn, cold cough, antidiarrhea (Jeruto <i>et al</i> 2008) Roots/Leaves are used for treatment of HIV/AIDS opportunistic infections (Kisangau <i>et al.</i> , 2007). Treats malaria, fevers and tuberculosis (Otieno <i>et al.</i> , 2008)	STIs infertility

<i>Capparis spinosa</i>	treats rheumatism, Zhou <i>et al.</i> , 2010), , (Nizar <i>et al</i> 2010). treatsupper respiratory infections	STIs, infertility, malaria fevers colds and flu
<i>Euclea divinorum</i>	used in treatment of malaria, fever, venereal diseases, anaplasmosis (Otieno <i>et al.</i> , 2008). It's used in treatment of venereal diseases, scabies leorosity rabies as anthelmintic (Aberra <i>et. al</i> , 2005)	STIs infertility typhoid wounds
<i>Euphorbia candelabrum</i>	Used in treatment of upper respiratory tract infections, gastrointestinal complications, wounds and coenuriasis (Otieno <i>et al.</i> , 2008), used for clearing afterbirth in women (Kokwaro, 2009), used for venereal diseases treatment (Pankhurst, 1990)	STIs infertility, asthma backache
<i>Acacia drepanolobium</i>	Used as antidiabetic, as a dental chewing stick, to treat gingivitis, stomatitis, laryngitis, Laryngitis, treats indigestion Used in treatment of retained afterbirth after birth besiosis,gastrointestinal complications (Ichikawa, 1998, Nanyingi <i>et al.</i> , 2008)	STIs infertility Arthritis
<i>Harrisonia abyssinica</i>	used in the treatment of venereal diseases, fevers malaria, diarrhea, urinary problems, and intestinal worms, coughs, dysmenorrheal, tuberculosis,infertility cancer snake bites, hernias migraine insanity.Terpene have been isolated from the plants (Balde <i>et. al.</i> , 2004	STIs, infertility arthritis, chest pains

<i>Hilderbranta</i>	Used as an anthelmintic (Gathuma <i>et. al</i> , 2004) Used in treatment of gastrointestinal	STIs infertility
<i>sepalosa</i>	complications and upper respiratory tract infections (Nanyingi <i>et. al.</i> , 2008)	malaria arthritis body aches
<i>Grewia simi L</i>	Used in treatment of Diarrhea (Marita <i>et, al.</i> , 2011)	STIs infertility stomach problems

Appendix 7:

Table 7.1 Clinical observations during 24 hours period after oral administration of aqueous extract of *Clerodendrum myricoides* from Samburu County.

GROUP	No. DEAD	RAT No.	DOSE mg/kg	CLINICAL SIGNS OF TOXICITY	OTHER OBSERVATIONS
GROUP 1 (n=3)	2	1	2000	Central nervous signs such as ataxia, circling, convulsions forelimb paresis, nausea were observed	The rat died within 30 minutes of dosing.
		2	2000	Salivation, lacrimation, nostril irritation, sneezing, photophobia, hypersensitivity	The rat died within 24hrs after dosing.
		3	2000	Salivation, nostril irritation, piloerection, shivering	The animal survived for more than 24 hours after it was dosed with at 2000 mg/kg body weight
GROUP 2 (n=3)	0	1	300	Piloerection, restless, nostril irritation, salivation, seeking for shade, gasping for air, photophobia Piloerection, restless, nostril irritation, salivation, seeking for shade, gasping for air,	The signs were seen in the three rats
		2		photophobia, lacrimation, drowsiness, cyanosis of the tail	

				nostril irritation, lacrimation, drowsiness, cyanosis of the tail.	
		3		Photophobia, lacrimation, drowsiness, cyanosis of the tail, nostril irritation	
Group3 (n=3)	0	1	300	Gasping for air, piloerection, restlessness, seeking the shade, photophobia, nostril irritation, darkening of eyes, sneezing, muscle twitching, cyanosis of the tail.	
		2		Gasping for air, piloerection, seeking for shade, photophobia, nostril irritation, darkening of eyes, sneezing, muscle twitching, cyanosis of the tail, unwilling to move	. Rat 3 recovered within 24 hrs
		3		Gasping for air, piloerection, seeking for shade, photophobia, nostril irritation, darkening of eyes, sneezing, muscle twitching, cyanosis of the tail, unwilling to move.	

The observations indicated that the LD₅₀ was 1000mg/kgbw (Appendix 4).

