

STRUCTURAL PERFORMANCE EVALUATION OF LANDOLPHIA BUCHANANII CONCRETE BEAMS

Michael Ketter¹, Timothy Nyomboi² and Sylvester O. Abuodha³

¹Department of Civil Engineering, Pan African University, Institute for Basic Science, Technology and Innovation (PAUISTI), JKUAT, Kenya.

²Department of Civil and Structural Engineering, Moi University, Kenya.

³Department of Civil Engineering, University of Nairobi, Kenya

ABSTRACT

The study sought to evaluate the performance of Landolphia buchananii concrete beams to establish the potential of Landolphia buchananii as structural reinforcement of concrete in beams. Tensile strength test on Landolphia buchananii was performed while flexural test was done on Landolphia buchananii reinforced beams and compared with steel reinforced concrete beams. Beams of 1100 mm length having 150mm width and 250 mm depth were used in the tests. Varying area of reinforcement of L.buchananii was used for beam specimens made of concrete of average compressive strength of 21.8N/mm². The steel reinforced beams were reinforced with standard 8mm High strength twisted bar as a tensile reinforcement. The results showed that the ultimate load for the L.buchananii reinforced beams was lower than that of control beams by about 65 % and therefore L. buchananii can only be used under low loading regimes such as in low rise lintel beams with load bearing walls.

KEYWORDS: *Landolphia buchanani*, Tensile strengths, Flexural strength, Ultimate load, Deflection.

I. INTRODUCTION

In building construction, majorly brick, concrete, steel and wood are normally used. Concrete as one of the major construction material has achieved its reputation since 1960's [1]. Steel is majorly used to reinforce concrete. Though steel has high tensile strength which complements the low tensile strength of concrete, there is growing cost and general shortage of reinforcing steel in many parts of the world. Ordinarily, use of steel should be very limited since it is costly, so much energy consuming and carbon dioxide (CO₂) emitting taking place in the manufacturing process [2]. This has led to increase in interest for alternative locally available materials for the reinforcement of concrete. Research on several vegetable fibers as a reinforcement of concrete has been done. Several researches have been done on the behavior of bamboo reinforced concrete [2] [3] [4] [5] [6] [7] [8]. Some researches has also been done on the use of mangrove [9] [10] and babadua [3] as reinforcement.

This study therefore focuses on another vegetable fiber: *Landolphia buchananii* plant. The focus in the study is on the structural capabilities of *Landolphia buchananii* as reinforcement in the concrete. *Landolphia buchananii* is part of *Landolphia* species. There are seventeen *Landolphia* species (Family *Apocynaceae*). They are forest lianas and sprawling shrubs having jasmine-scented flowers and plentiful fruits and latex filled stems [11]. *Landolphia buchananii* can grow up to forty meters tall. Its trunk can grow up to twenty three centimeters in diameter. It's found in East Africa, Ethiopia, Sudan, Mozambique, Democratic Republic of Congo, Zambia, Angola, Cameroun and Nigeria. It grows well

between altitudes of 0-2500m. It is composed of roots, long stem and leaves/ branches at the bottom, middle and top respectively [12].

In this paper, experimental investigation and evaluation of the use of *L.buchananii* as reinforcing bar in concrete as a replacement for steel is presented.

II. MATERIALS

2.1 Fine Aggregate

In this study river sand was used as fine aggregate. It was selected as specified in accordance to BS 882 [13]. This was done through grading from sieve analysis test in accordance to BS 410 [14]. The results were as shown in table 1.

2.2 Course aggregate.

Crushed stone of 20 mm nominal diameter was used as course aggregate. It was selected as specified in accordance to BS 882 [13] through sieve analysis test as per BS 410 [14]. The results were as shown in table 1.

Table 1: Aggregate sieve analysis test results

BS sieve size	Percentage passing, %	Percentage retained, %	Cumulative retained, %
Course aggregate			
31.7 mm	100	0	0
20 mm	100	0	0
14 mm	51.6	48.4	48.4
10 mm	23.6	28	76.4
5 mm	6.5	17.1	93.5
Pan	0	6.5	
Fine aggregate			
5 mm	100		
2.36 mm	99.2	0.8	0.8
1.18 mm	82.1	17.1	17.9
600 µm	48.2	34	51.9
300 µm	11.9	36.3	88.2
150 µm	2.5	9.3	97.5
Pan		2.5	

2.3 *Landolphia buchananii* stems

The *L.buchananii* stem were sourced from Nandi forest in western part of Kenya. Mature and straight stem with minimal defects stems were selected dried and prepared so as to be applied in form of a reinforcement bar.

2.4 Steel bars

The bars used were the high strength yield twisted steel bars of diameter 8 mm and mild steel round bars of diameter 8 mm as specified in accordance to BS 8110 [15].

III. SAMPLE PREPARATION

3.1 *Landolphia buchananii* stems

L. buchananii stems were cut and dried and the bark was removed. Generally uniform stems along their lengths were selected. For each stem for reinforced concrete beam specimen, diameter was measured at three positions then averaged; the positions were at the ends and the middle of the stems. For the tensile test, the test specimens were prepared in accordance to BS 373 [16].

3.2 Concrete Mix preparation

Standard nominal mix proportion of 1:2:4 (cement: fine aggregate: coarse aggregate) by volume was adopted with target strength of 20 N/mm². Slump value was maintained at 31-37 mm to avoid excess water which can cause the swelling of the stem. The local Portland Pozzolana cement as per Kenya standards was used. Maximum size of aggregate used was 20mm. Standard nominal mix proportion by volume was adopted from BS 8500 [17].

3.3 Reinforced beam specimens

In this study, beams with varying areas of reinforcements were used. There were six beams, each with shear reinforcement of 8 mm diameter mild steel provided at a spacing of 200 mm center to centre throughout the length of the beam. The size of the beams was 1100 mm length with 150 mm width and 250 mm depth. The areas of tensile reinforcements were 805(2.14%), 787(2.1%), 741(2%), 710(1.9%), 419(1.11%), 399(1.1%) mm² of *L. buchananii* stem. For the top reinforcements, two *L. buchananii* stems of diameter 10mm were used for all specimens.

The cover to the links of each beam was 20mm. Poker vibrator was used to compact the concrete in the formwork. The formwork was removed after 24 hrs and the beam specimens were cured for 28 days by keeping them in wet conditions. Concrete cubes of 150x150x150mm were casted alongside the beams and cured in a water tank for 28 days. Figure 1 shows the cross section of the beams specimens. The following notations have been applied for ease identification throughout this paper:

L.B.805: Beam with 805 mm² area of reinforcement of *L.buchananii*.

L.B.787: Beam with 787 mm² area of reinforcement of *L.buchananii*.

L.B.741: Beam with 741 mm² area of reinforcement of *L.buchananii*.

L.B.710: Beam with 710 mm² area of reinforcement of *L.buchananii*.

L.B.419: Beam with 419 mm² area of reinforcement of *L.buchananii*.

L.B.399: Beam with 399 mm² area of reinforcement of *L.buchananii*.

Steel 101: Beam with 101 mm² area of reinforcement of steel.

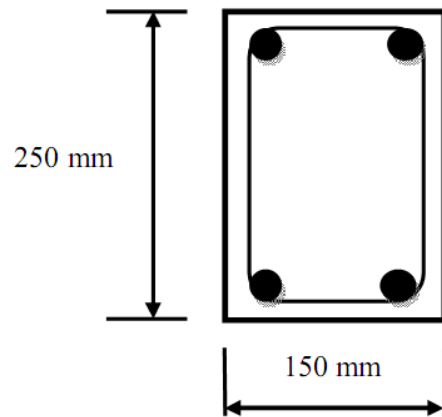

Figure 1: Cross-Section of Sample Concrete Beam

IV. EXPERIMENTAL PROGRAMME

The programme entailed determination of compressive strength of cubes, tensile strength of *L.buchananii* and flexural strength of the *L.buchananii* reinforced concrete beams and steel reinforced beams. The testing procedures were as summarized below:

4.1 Tensile strength test of *Landolphia buchananii*

The test was done in accordance to BS373 [16] parallel to the grain. The actual dimensions at the minimum cross-section were measured. The load was applied at 2 cm face of the ends of the test piece by special machine grips. The shape and dimension of the specimens were as shown in figure 2. The tensile load was applied gradually to the test piece at a constant head speed of 0.127mm/min.

4.2 Beam flexural test and cube compressive test

Flexural test was conducted base on three point loading arrangement as shown in figure 3 after 28 days of curing. The span between the supports centers was 900 mm. Displacement transducer was used to measure deflection at mid-span. Loading was applied at mid-span of the beam gradually to failure. The load and deflection were recorded at intervals. First crack load and crack type was also observed.

Compressive test was performed on concrete cubes specimen after 28 days and their respective strengths determined.

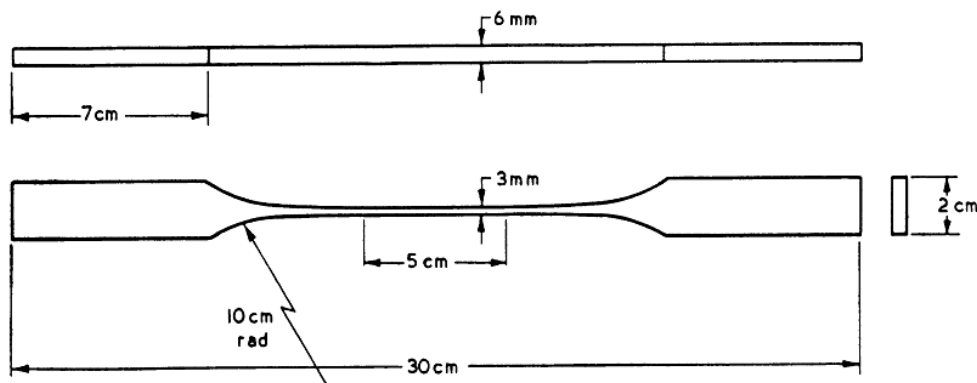

Figure 2: Test piece for tension parallel to grain test

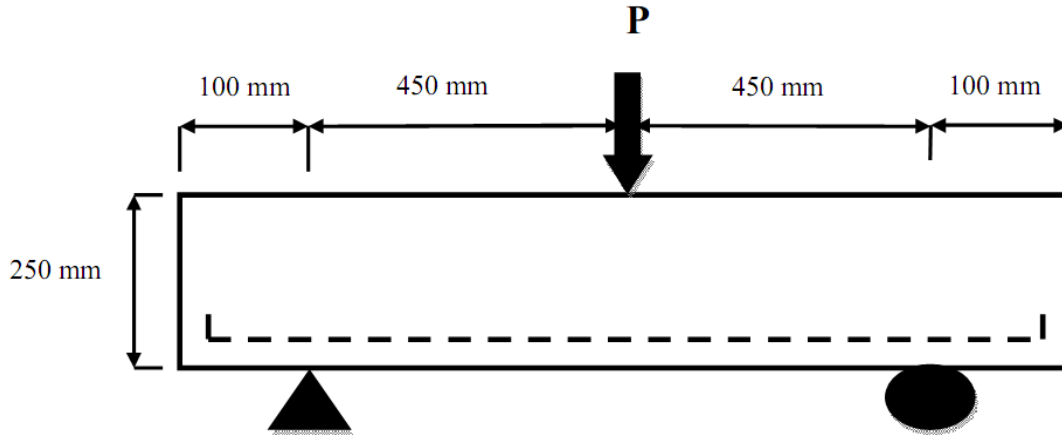

Figure 3: Three Point Bending Test Set Up

V. TEST RESULTS AND DISCUSSION

5.1 Tensile strength of *Landolphia buchananii*

In all the tests, failure occurred near the portion prepared for the grip as shown in figure 4. Tensile strength varied from one specimen to another because *Landolphia buchananii* is natural material and its defects as wood/timber vary from one another. As provided in BS 5268[18] the factor of safety of 0.8 was applied to tensile strength to take in to account for the defects. Therefore the characteristic tensile strength was approximately 69 N/mm^2 which is around 15% that of conventional high strength steel. Although the *L. buchananii* tensile strength is lower than that of steel, *L. buchananii* can be used as reinforcement of concrete beams where the loading can be accommodated within the tensile strength. Such application can be in ring and lintel beams of load bearing walls where the beams carry minimal load but acts pronominally as a tie beam.



Figure 4: Mode of failure of tensile test samples

5.2 Compressive strength

The average compressive strength of concrete cubes of 150 mm by 150 mm by 150 mm after 28 days was 21.8 N/mm^2 . The target strength for the concrete used in the study was 20 N/mm^2 .

5.3 Beam flexural strength

Load-deflection curves of *L. buchananii* reinforced concrete beams (L.B. 805, L.B. 787 and L.B. 741) and steel reinforced beam (control) have been compared in figure 5. The beam with largest area of

reinforcement (L.B.805) had an ultimate load of 19.6 kN at a deflection of 9.8 mm while that of steel reinforced concrete beam (steel 101) was 56.25 kN at a deflection of 14.94 mm. The other *L.buchananii* reinforced beams with lesser areas of reinforcements showed lower ultimate load at failure with corresponding lower deflections as shown in table 1.

It can be seen from figure 6 that flexural failure mode of the *L.buchananii* reinforced beams occurred. From figure 8, it can be seen that that *L. buchananii* reinforcement did not fracture at failure; however flexural cracking is noted in the concrete. This confirms that the flexural failure may have occurred prematurely due to failure in bonding between *L. buchananii* and concrete, resulting in de-bonding and pullout. Generally the steel reinforced concrete beam was stiffer than *L. buchananii* reinforced concrete beam. The general ductile characteristic behavior of steel reinforced beam was noted in both *L. buchananii* and steel reinforced beams can be attributed to elastic properties of the two reinforcement materials. The results showed that the load carrying and deflection capacity depends on the area of reinforcement of *L. buchananii*. The larger the area of reinforcement of *L. buchananii* the higher the load carrying and deflection capacity. From figure 5, it can be observed that the *L. buchananii* reinforced concrete beams exhibit lower elastic stiffness as compared to steel reinforced concrete beams. This difference in elastic stiffness is attributed to lower modulus of elasticity of *L.buchananii* stems.

Table 2 shows the areas of reinforcements, cracking loads, ultimate load capacities, and mode of failure and maximum deflection of both *L. buchananii* reinforced concrete beams and steel reinforced concrete beams.

Table 2: Summary of Beams Results

Specimen	Span, mm	Reinforcement Area		First crack load		Maximum Load		Failure mode
		Tensile Area (mm ²)	Shear dia. mm	First crack, kN	Moment at first crack, kNm	Max. load, kN	Max. moment, kNm	
Steel 101	900	101(0.27%)	R8	56.25	12.7	56.25	12.7	Flexure
L.B. 805	900	805(2.14%)	R8	7.5	1.7	19.6	4.4	Flexure
L.B. 787	900	787(2.1%)	R8	8.15	1.8	17.3	3.9	Flexure
L.B. 741	900	741(2%)	R8	8.5	1.9	13	2.9	Flexure
L.B. 710	900	710(1.9%)	R8	7.4	1.7	15.5	3.5	Flexure
L.B. 419	900	419(1.11%)	R8	11.9	2.7	11.9	2.7	Flexure
L.B. 399	900	399(1.1%)	R8	11	2.5	11	2.5	Flexure

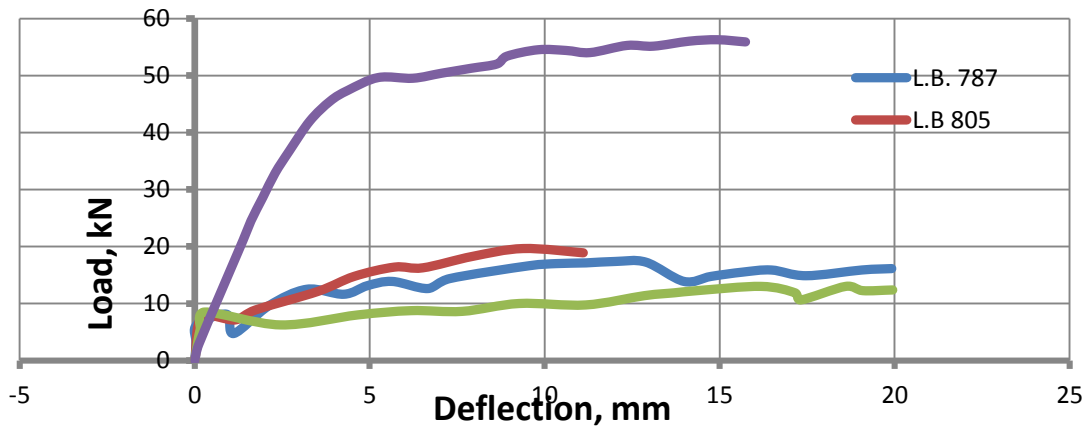

Figure 5: Load-Deflection Curves for *L.buchananii* reinforced concrete beam.



6.1: Failure pattern of L.B. 805



6.2: Failure pattern of L.B. 787



6.3: Failure pattern of L.B. 741



6.4: Failure pattern of L.B. 710



6.5: Failure pattern of L.B. 419



6.6: Failure pattern of L.B. 399



6.7: Failure pattern of Steel 101

Figure 6: Flexural failure Pattern of Beams



Figure 7: Snap steel tensile reinforcement



Figure 8: Slipped *L.buchananii* tensile reinforcement



Figure 9: Unsnapped *L.buchananii* tensile reinforcement

5.4 Failure modes of the beams

Flexural failure is noted in all the beams as shown in figure 6 with crack gradually starting at mid span and enlarges as the loading was increased. From figure 5 the loading deflection curves and the failure pattern *L.buchananii* reinforced beams (figure 8 and 9) as compared to that of the steel reinforced beam (figure 7). It can be noted that bonding failure could be the probable cause of the premature flexural failure in the *L.buchananii* reinforced beams. It can be seen that the tensile reinforcement was still intact but had slipped through the concrete while steel tensile reinforcement snapped as shown in figure 7. When the region of failure crack was examined in figure 9 the *L.buchananii* stem seem unbroken, suggesting that there was a poor bond between *L.buchananii* and concrete which led to beam failing in bonding.

VI. CONCLUSION

This study provides insight on potentiality of *L. buchananii* as a reinforcement of concrete. The following conclusions can be drawn from this study:

- (a) The characteristic tensile strength of *Landolphia buchananii* was lower than that of conventional steel by about 85%.
- (b) Flexural strength of *L. buchananii* reinforced concrete beam increased with increase in area of reinforcement of *L. buchananii*.
- (c) The mode of failure of *L. buchananii* reinforced beams was due to bending and failure in bonding between concrete and *L. buchananii*.
- (d) There is need to investigate characteristic behavior in detail of the bonding of *L. buchananii* when used as reinforcement of concrete.

REFERENCE

- [1] B. I. G. Barr. (1992). "Fibre reinforced concrete-where do we go from here?" Proc., Fourth RILEM International Symposium on Fibre Reinforced Cement and Concrete, Ed., R.N. Swamy, London: E and FN Spon., pp. 3-11.
- [2] Harish Sakaray, N.V. Vamsi Krishna Togati and I.V. Ramana Reddy. (2012). Investigation on properties of bamboo as a reinforcing material in concrete. International Journal of Engineering Research and Application (IJERA). Vol.2, ISS01 pp. 077-083.
- [3] Adom-Asamoah Mark, Afrifa Owusu Russell. (2011). A comparative study of Bamboo reinforced concrete beams using different stirrup materials for rural construction. International Journal of Civil and Structural Engineering. ISSN 0976 – 4399 .Volume 2, No 1, 2011.
- [4] Amada, S. and Untao, S. (2001), "Fracture Properties of Bamboo", Composites Part B, Vol. 32, pp 451-459.
- [5] Ghavami, K. (1995), Bamboo as reinforcement in Structural Concrete Elements. Elsevier Cement Concrete Composites 1995; 17(4):281–8.
- [6] M.M Rahman, M.H. Rashid, M.A. Hossain, M.T. Hasan and M.K. Hasan. (2011). Performance evaluation of bamboo reinforced concrete beam. International journal of engineering and technology, (IJET-IJENS) Vol. 11, No.21.
- [7] Tara Sen, H. N. Jagannatha Reddy. (2011). Application of Sisal, Bamboo, Coir and Jute Natural Composites in Structural Upgradation. International Journal of Innovation, Management and Technology, Vol. 2, No. 3.
- [8] M.D. Ahsan Sabbir, S.M. Ashfaqul Hol, and Saiada Fuadi Farcy (2011). Determination of Tensile property of Bamboo for using as a potential reinforcement in the concrete. International Journal of Civil and environmental Engineer Vol. 11 No: 05.
- [9] Manguriu, G., Oyawa, W., & Abuodha, S. (2013). Physical and mechanical properties of mangrove from Kilifi in Kenya. Global Engineers & Technologists Review, 3, 1-5.
- [10] Kallemana Aze Kerte, Timothy Nyomboi, Walter Oyawa.(2014). Structural performance of magroove reinforced concrete beams. International Journal of Engineering Sciences & emerging Technologies. Vol. 7 No 1.

- [11] National research council of the natural Academies (NRCNA). (2008). Lost crops in Africa: Volume III: Fruits. The National Academies press Washington D.C.
- [12] J.G.M. Persoon, F.J.H. van Dilst, R.P. Kuijpers, A.J.M. Leeuwenberg and G.J.A. Vonk (1992). The African species of *Landolphia* P. Beauv. Series of revisions of Apocynaceae XXXIV. First edition. Kluwer Academic Publishers, Dordrecht/Boston/London.
- [13] BS 882. (1992). Specification for aggregates from natural sources for concrete. UK, London.
- [14] BS 410. (1986). Specification for test sieves. UK, London.
- [15] BS 8110-1. (1997). Code of practice for design and construction. UK, London.
- [16] BS 373. (1957). Methods of testing small clear specimen of timber, UK. London.
- [17] BS 8500. (2006). Method of specifying and guidance for the specifier. UK, London.
- [18] BS 5268-2. (2002). Structural use of timber-Code of practice for permissible stress design, materials and workmanship. UK, London.

AUTHORS

Michael Ketter, currently Master's student in Civil Engineering (Structural Option) at Pan African University, Institute for Basic Science, Technology and Innovation (PAUISTI), JKUAT, Kenya.



Timothy Nyomboi is a part time Senior lecturer at Pan African University Institute for Basic Sciences Technology and Innovations (PAUISTI), Senior Lecturer at Moi University (on leave of absence), Design and Construction Manager Kenya Urban Roads Authority. He has several publications in refereed journals and Conferences. His areas of interest are in Construction, Sustainable Construction material, Structural Engineering, and Design.



Sylester Abuodha is a part time Thesis Supervisor at Pan African University Institute for Basic Sciences Technology and Innovations (PAUISTI), Senior Lecturer at University of Nairobi. He has several publications in refereed Journals and Conferences. His areas of interest are in Structural Engineering, Civil Engineering materials and Finite Elements Analysis.

