

TECHNICAL PAMPHLET No 1

BETTER BURNT BRICKS

by
T.I. Svare

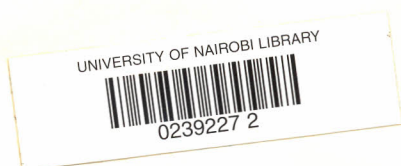

National Housing and Building Research Unit

MINISTRY OF LANDS,
HOUSING AND URBAN DEVELOPMENT

DAR ES SALAAM 1974

In the ongoing drive for utilization of local building materials, burnt clay bricks will play an important role.

Suitable clay can be found all over the country. Firewood for burning is available in most parts. The skills of moulding and burning bricks in field kilns are present, but need to be more widely known.

We hope that this pamphlet will be of help to all those who are involved in housebuilding and want to build good permanent houses of burnt bricks.

For Villages and Cooperative housing societies the bricks give a possibility to build permanent houses by little or no cash expenditures. When the skill of brickmaking is there, the next step should be to make roofing tiles, flooring tiles etc. in burnt clay materials.

Hand-made bricks may reach a very high quality if some few precautions are undertaken. This is important when bricks are made for sale. However very small expenditures are required for improved, hand-made clay bricks.

Many small brick-making teams may altogether produce the same quantities and qualities as a factory. It only takes some organisation. If no specific body exists, the District Development Corporations are responsible for this. The brick-making teams must produce bricks of equal size and quality and whenever big projects like schools, administration centres etc. are being planned, the production of bricks and tiles must be organized in time to fulfill the requirements.

This kind of production will give :

- High employment
- Small capital investments
- Utilization of local materials
- Small transport costs,
and extremely good, permanent houses.

By some clever organisational enterprising the hand-production can be doubled, trippled or multiplied to a high degree much faster than any industrialized production.

We hope this pamphlet will encourage you.

June 1974.

Harald Kristiansen,
Director.

C O N T E N T

INTRODUCTION	7
S E C T I O N 1	9
EXISTING PRODUCTION	9
FUTURE DEVELOPMENT OF BRICK PRODUCTION	10
Hand Production of Bricks - Self-help	11
Hand Production of Bricks - For Sale	12
Small Factories	12
Large Factories	14
S E C T I O N 2	15
WINNING OF SOIL	15
PREPARATION OF SOIL	15
BRICK PRODUCTION	16
Simple Hand Production - Self-help	16
Improved Hand Production - For Sale	18
Making Moulds	19
Moulding Bricks	19
Drying Bricks	21
BURNING BRICKS	22
Field Kiln	23
Building the Kiln	23
Firing of Kiln	25
Permanent Kiln	26
S E C T I O N 3	30
SOIL SUITABILITY FOR BRICK MAKING	30
Testing the Soil	31
STANDARDIZATION OF BRICKS	32
Brick Size	33
Compression Strength	35
Mortar	35
ACKNOWLEDGEMENT	37

INTRODUCTION

Development of clay building materials has accompanied the development of civilization. Clay products are the oldest artificial building materials in existence. The use of bricks in construction can be traced back more than five thousand years.

The oldest known evidence is from the Indus Valley Culture. Excavations of Mokenjo-Daro in Pakistan show that these pre-Aryan people made wide streets, tall building and had an extensive and efficient water and drainage system. Bricks were used for multi-storey houses, paving streets, water and sewage ducts and for swimming pools.

As far as we know the first burnt clay bricks in Africa used for construction, were introduced by the Romans about two thousand years ago. We know of older burnt clay products in Egypt, but these were used for other purposes. The oldest buildings made of bricks in Africa are from Fipasa (Algeria), Leptis Magna (Libya) and in Tunisia. From the Arabic period there are buildings dating back to the ninth century.

Many other building materials have also been developed, such as concrete products, asbestos cement products, different wood and wood based products, and plastic products. Despite this competition clay products play an important role in modern housebuilding. This because they have many advantages compared to most other building materials. These are :-

- Easy to form the clay into the desired shape and size.
- The weather resistance is very good.
- Almost maintenance free.
- Easy to produce at different scales of industrialization.
- Utilizing local raw materials.
- Good architectural properties.

We believe that an increased production of burnt clay bricks are very important in Tanzania. This because we are in a great need for cheap permanent building materials. This can be illustrated by giving a few figures. There are an estimated 3.5 million housing units in Tanzania at present, of which more than 3 million are traditional rural houses. About 600,000 traditional houses are built annually, but 500,000 of these are needed to replace decayed houses.

Most of the effort is therefore directed toward replacement of old houses.

By 1995 the population will have doubled and the required housing stock will be between 6 and 7 million units. If the entire Tanzanian population were to be housed in permanent houses by 1995, about 6 million additional units would have to be built. It is estimated that a permanent house, built by self-help, in 1973 costed about Shs.2,000 (Material costs for foundation, floor and roof). If 6 million such houses were built it would cost Shs.12,000 million.

This is 13.5% of estimated investible resources, both private and public, available for Tanzania from 1975 - 1995. Currently housing construction accounts for about 5% of total capital formation in the monetary economy. With competing demand from agriculture, industry, education, water, and other sectors, it is unlikely that 13.5% can be used for building permanent houses. But it is clear that the number of houses built can be substantially increased through self-help construction. One of the most important ways in which monetary investment costs in permanent housing can be reduced is through the use of hand-made bricks.

The purpose of the pamphlet is to give informations to those who are or will be engaged with promotion of burnt clay bricks. There are three main sections which can be studied seperately. The first section try to outline the direction of future development. After this we give advises on how brick production should be carried out, and we end up with a discussion of standardization and simple testing procedures for determining a soil's suitability for brick-making.

EXISTING PRODUCTION

The largest advantage of using burnt clay products in Tanzania stems from the fact that they can be produced from purely local materials, and with little or no investments. Some cement and / or lime is usually required for jointing bricks, but lime / cement mortar has been successfully substituted with thin joints of mud.

Some of the finest examples of architecture and craftsmanship in Tanzania are to be seen in churches and schools built of burnt bricks. This demonstrate that very good bricks have been made from local materials, and their quality being matched by the high standards of workmanship in the bricklaying.

The skills of burning bricks and tiles were introduced by the Catholic Fathers. This has resulted in a wide use of bricks burnt in field kilns by the people themselves in parts of Ruvuma, Iringa, Mbeya, Rukwa, Kigoma and West Lake Regions. Other regions where brick-making is known are : Tanga, Kilimanjaro, Arusha, Shinyanga, Singida and Morogoro.

A team of four produces about 15,000 hand made bricks a month. This is enough brick for one of the low cost houses built by N.H.C. In average a team can make sufficient bricks for 8 to 10 houses a year (no production in the rainy season).

Machine made bricks are at the moment available from Soni, Morogoro and Iringa, while plants near Dar es Salaam, Arusha and Dodoma are not producing. These plants will probably soon be reopened. In addition to the above mentioned plants some missions have simple extruders, but they only produce for their own consumption.

The existing factories are small and very simple, and it is only the shaping (using small extruders) of the bricks which is done mechanically. All other operations are done by hand. The burning is done in field kilns or in semi-permanent kilns. The capacity of each of these plants are between 1.2 and 2.4 million bricks a year

(equivalent to 80 - 160 houses). All extruders are old and most of them are of Italian make.

When the closed down plants are reopened the total production capacity will most probably be between 1000 and 1500 houses a year (including existing hand production).

The quality of hand-made bricks are many places good. Where the right type of soil is found, the bricks will have a sufficient strength to be used in two storey buildings. (compression strength 30 - 40 kgf/cm²).

The simple extruders used to day are producing bricks with a compressive strength on about 100 kgf/cm². This strength correspond to the compressive strength specified in most countries as "common bricks". Most standards say that these bricks can be used in all types of masonry which do not have to resist the action of freezing and thawing.

Experience has indicated that any well-burned brick will resist the action of weather over a long period of time, and may be considered very durable.

FUTURE DEVELOPMENT OF BRICK PRODUCTION

In the previous section we discussed the present brick production in Tanzania. We will here briefly talk about the production of tomorrow.

We will divide the production in three major levels. These are :-

- Hand production of the bricks, using field kilns for burning.
- Small factories using simple mechanical machinery for forming the bricks, using field kilns or permanent kilns for burning.
- Large factories using continuous kilns for burning and mechanical methods in most operations.

There is actually a range of intermediate technologies between the simplest form and the most mechanized, but most of the current or potential brick production will closely approximate to one of the three types listed.

There are also two major markets for burnt clay bricks :

- Rural housing and self-help housing in towns
- Urban houses built by contractors or by other types of paid labour.

The majority of rural houses are and will be built by self-help. Burning bricks and building a brick wall may be done without spending money, but it is time consuming. People may use bricks if they are strongly encouraged to do so, and if they are properly trained. People may obtain a permanent building product by only investing their own labour.

Bricks made for sale have to compete economically with other wall materials. The amount of work involved in the production will greatly influence the price, while for self-help the labour is free.

We must have this division of market in mind when we are discussing the future development of hand production.

Hand Production of Bricks - Self-help.

The simplest way to produce bricks are to mould them directly on ground, and burn them in a field kiln.

The quality of these bricks vary from good to poor, their dimensions are variable and the surfaces rough, but they are satisfactory for small houses and single storey public buildings. If firewood is available the money needed for production of hand-moulded bricks will be very small.

Simple-hand production of bricks is one of the cheapest ways to improve self-help housing. If the self-help builders invest their own labour, burnt clay bricks can be produced with very small cash expenditures.

Brick production for self-help housing will have an enormous effect on housing conditions, and with the traditional way of hand production, output can be increased very much within a short period of time. We think that this production should be strongly encouraged everywhere.

Hand Production of Bricks - For Sale

One of the main disadvantages with our hand-made bricks to day is the rough surface and the variable quality, but this can be improved. When hand-made bricks are made today the green bricks are usually placed directly on the ground for drying in the sun. Since the ground never is completely even, the bricks will not be even either, and loose particles will be picked up by the wet bricks. This can be improved by drying the bricks on boards (planks), and by closer attention to mixing and watering of the soil. After three days of drying, the bricks can be stacked in a pile for further drying. This mean that boards for three days production are needed. The brick piles should be protected against rain while drying. This can be done by constructing simple drying sheds made from bush poles with a thatched roof. These improvements can be done for an investment of about 1,000/=.

The quality of hand-made bricks can be further improved by moulding the bricks on a table, drying the bricks in a shed, and by improving the burning. This will require some capital investments. In a later section we will give recommendation on how this production should be carried out. The structural quality of these bricks may be very good.

A hand-made brick is today sold for 4 to 10 cents each. All kinds of mechanical production will result in a more expensive product. This does not mean that all production should be done by hand, but as much as possible should be produced in this simple way.

Improved hand production increase output and quality, and it should be strongly promoted as small scale industry. In areas where the demand for bricks are small and fluctuating, it is the only solution for brick production.

Small Factories

All factories presently producing bricks in Tanzania can be placed in this group.

We believe that hand production should be developed as far as possible, but in some medium and large size cities an industrialized production have to be used to meet demand for high quality bricks.

The reasons are :-

- To hand-make very good bricks needs great skill, while shaping bricks by an extruder require unskilled labour.
- It may be difficult to organize a hand production of the same size a simple extruder can produce.
- Machine-made bricks may also have a higher strength than what can be obtained by hand production.

For small factories we think that a extruder in combination with a manually operated wire cutter is the best solution. The extruder should be as simple as possible. Preferably it should be driven by a small diesel engine. The only part which needs regular maintenance is the engine, and that can be done in the nearest garage. To operate a such extruder is simple and can easily be learned.

All extruders on the world market to-day have a capacity of 25,000 or more bricks a day. At this production the burning of the bricks has to be done in a continuous kiln. To build a continuous kiln will cost from Shs.500,000 to 700,000. When we are thinking on small factories the burning is done in smaller and much cheaper kilns. The maximum production for burning in small permanent kilns are about 15,000 bricks a day or equivalent to 300 houses annually. When we are talking about a small factory we are therefore thinking of a maximum production of less than this.

Machinery which is available on the world market is bigger and more advanced than needed for a small factory. The simplest extruders produced to day cost Shs.60,000 to 80,000. Small Industry Development Organisation (SIDO) and the National Housing and Building Research Unit (BRU) are therefore trying to make a simple extruder. The cost of the extruder (including engine) will probably be less than Shs.15,000. The purpose is not to develop a new type, but more or less to copy simple machines which successfully have been used elsewhere.

If the cutting of the bricks are done by a simple frame which cut two bricks a time, the production will be about 5,000 bricks a day. This production is equivalent to 100 houses annually.

Burning of the bricks can be started in field kilns, and later when time allows it, permanent kilns can be built with bricks from

its own production. The total investment will be less than Shs.30,000. If a further increase in production is needed, a hand-operated cutting table can be bought for a cost of about Shs. 20,000. The production capacity can then be increased.

The advantages of a small plant compared to a big one are :-

- Small capital investments.
- Easy to expand to meet higher demand.
- Absorbs easy fluctuations in demand.
- Labor intensive.
- Easy to operate and maintain.
- Short transport to building sites.
- Low consumption of oil.

Large Factories

If high quality bricks are needed in a large quantity a big factory may have to be built.

According to a survey done by National Housing Cooperation the cost of a factory which produces 24,000 bricks a day is about Shs.1 million. The production cost per brick from this factory is about 13 cents when it produces at full capacity. Before a factory of this size is built a thorough market survey has to be done. The main reason for this is :-

- A very large part of the production cost is due to depreciation of investments. Depreciation costs are constant regardless of production. This makes the production very sensitive to fluctuations in demand.

When the market survey is done close attention should be paid to the transport costs.

According to calculations we have made the only place where there are a clear need for a large factory is in Dodoma. With increasing labour costs and increasing demand for high quality bricks this will change. In those cities where a large factory is needed in 5 to 10 years the plans can be drawn up for this, but the building up should be done in stages.

WINNING OF SOIL

Regardless of choice of technology, it will be generally found economic to manufacture the bricks at the clay-site, as this will save transport costs. The soil can easily be dug by a small gang of men using hoes and shovels. If the soil must be obtained at some distance from the brickworks, then supervision of these men may be difficult. It will then probably be more economical to pay for the soil by the truck-load.

If the soil pit is adjacent to the brick-making plant wheel barrows can be used to transport the soil, if at some distance a truck must be used.

The soil should be dug or sliced in small pieces, so that stones or any other objectionable substances can be readily thrown aside.

PREPARATION OF SOIL

Proper preparation of the soil is a must if the bricks shall be of good quality. This operation is very much neglected today.

In Tanzania we can find many good clay deposits which can be utilized by using simple methods for soil preparation.

If the soil is a river silt it may happen that no preparation is needed, but usually the clay is obtained from the side of a hill or in the plains, and the soil will be fairly dry, and water will need to be added and mixed in. This can be done by applying water to the soil, and then mixing it thoroughly with shovels before moulding.

When the soil is lumpy and difficult to break down it is brought to the place which has been selected for moulding and air drying.

A flat heap is made and water is sprinkled on it. Then it is left like that for a few days to temper. The heap should not be allowed to dry up by wind or sun. It should be covered either with a layer of sand, mats, sacks, grass etc. Even if it is covered water may have to be added.

After four to five days of tempering the soil should be mixed thoroughly by turning the heap over two to four times with a spade or a hoe, slowly adding water until the desired consistency is obtained. At the same time the soil should be kneaded by tamping in it with the feet. If conscientiously done, treading produces a more uniform soil than by machine. If extra sand is required, it should be added at this stage.

In order to get a homogenous soil with good plasticity it is necessary that the mixing is done properly. The soil should also be as stiff as possible when the bricks are moulded. Generally it can be said that stiffer the soil is, the better the quality of the final product. It has to be added that a too stiff soil will be difficult to mould.

BRICK PRODUCTION

Only production methods which are of general interest are discussed.

Simple Hand Production - Self-help.

Remove all trees, plants, etc., from the site and level the ground.

The site should be arranged such as to avoid unnecessarily long transportation of the soil from the pit to where the soil is moulded into bricks. Similarly, the kiln should be situated as near as possible to avoid breakage of the dried bricks.

Simple moulds can be made as shown in Fig.1. Moulds are usually made with one to five compartments, but from the point of view of saving work, three to five compartments are preferable. The mould is a frame without bottom or lid.

The final size of the bricks should be 23cm x 11cm x 6.5cm. The mould has to be bigger than the brick to allow for drying and firing contraction. Fig.1 shows the mould size we recommend to use. Since

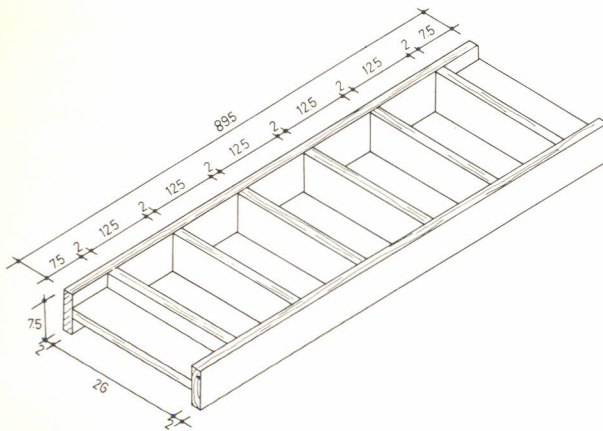

Fig.1. Simple mould with five compartments.
(All dimensions in cm)

the contractions will vary with soil type and water content the given mould size will not produce bricks of the same size everywhere. After experience is gained the moulds should be adjusted, if required, to produce 23cm x 11cm x 6.5cm bricks.

Because the wooden moulds will spend most of their time in water, they should be thoroughly soaked in oil (can be old engine oil) before ever being used. This treatment will prolong the life of the moulds and prevent damage.

Before moulding, the mould must be kept immersed in water for some time. If it is not thoroughly soaked, the bricks will stick to the mould.

Place the wet mould on very well levelled ground. Then take a lump of well mixed soil and fill the mould, kneading the soil until all corners are filled. Any surplus soil is scraped off with a straight piece of wood or metal.

Lift the mould carefully and leave the bricks on the ground for drying. The mould is again dipped in water, and the process repeated.

After about one day of drying in the sun or when the bricks have become sufficiently hard, they should be placed on edge and left for about eight days on the ground.

The bricks may then be stacked near the site of the field kiln until this can be built.

The bricks must be protected from rain while drying and in some cases it may be necessary to build sheds for this purpose.

Improved Hand Production - For Sale

When bricks are produced for sale the product has to meet certain quality requirements. These are called standards. When a large project is planned structural qualities and brick sizes have to be known. Lack of standardization has also prevented smaller producers of hand-made bricks from joining forces and producing for large projects. Standardization is discussed in the last section of this pamphlet, and we recommend everybody who will be engaged in production to study this carefully.

There are two main disadvantages with the hand production we just have talked about, and those are :-

- Very rough surfaces
- Poor structural quality.

In the following we will recommend on how this can be improved.

A smoother surface can be obtained simply by moulding the bricks on a board (plank) instead of directly on ground. After three days of drying the bricks can be removed if they are handled carefully. It will cost about 1,000/= to buy boards for three days production. (Dar es Salaam Price May'74).

To improve quality further, closer attention should be paid to tempering and mixing of the soil, and to the drying of the bricks. Sun drying may dry the bricks too fast, with cracked and deformed bricks as a result. Where the humidity is low the green bricks may also dry too much. If unburnt bricks reabsorb water cracks occur, which show as waste after firing.

In the method described below, the moulding is done on a table. This makes it easier to use a stiffer clay than that used in the methods previously discussed. The drying is done in sheds to prevent the sun and wind from drying the bricks too fast.

A team of two are able to produce 500 good bricks a day. The work is hard and great skill is needed.

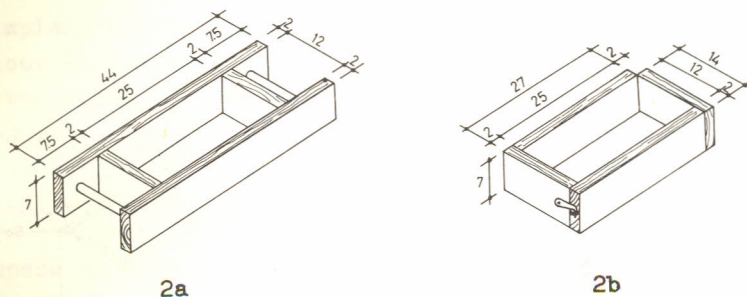

Fig.2. Two types of hand-moulds.
(All dimensions in cm)

Making Moulds

Fig.2 show the two most used mould types. They are made of hard-wood, and should preferably be lined with steel sheets to give longer life. The moulds have to be larger than the bricks to allow for drying and firing contraction. The mould size required for a particular clay to produce a 23cm x 11cm x 6.5cm brick will vary. The final size can be determined by laboratory tests, or by trial and error. If the last solution is used, the first mould size tried could be as given on Fig.2.

The mould shown in Fig.2b enables the brick to be removed more easily from the mould. This type enables stiffer clays to be used than the type shown in fig.2a.

Moulding the Bricks

A moulding table is shown on Fig.3.

The bricks are prevented from sticking to the mould by one of the following methods :-

- (a) Dusting the wet mould with sand between mouldings.
- (b) Keeping the moulds immersed in water.

(c) Oiling the mould with a brush or rag when required.

Method a is usually the best.

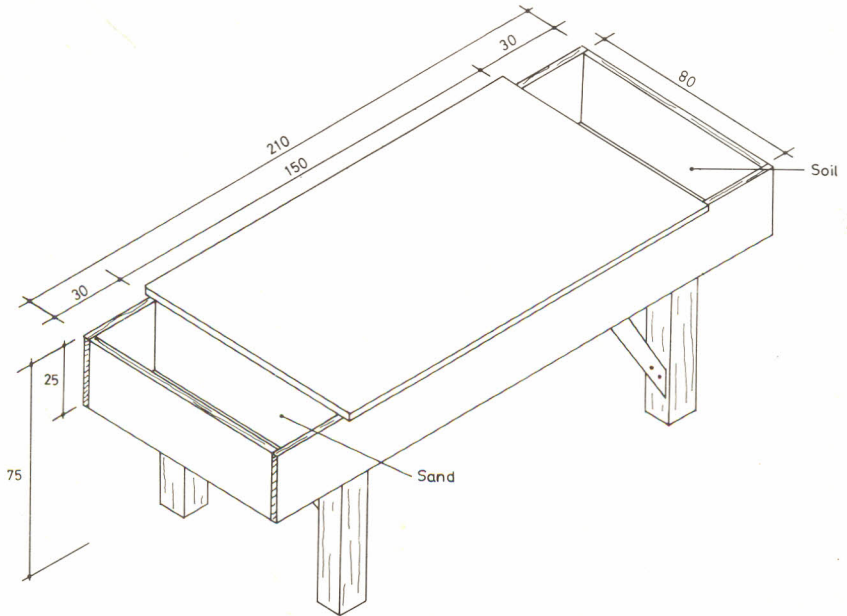

Fig.3. Moulding table. (All dimensions in cm)

The mould is placed on a false bottom called a pallet, which may be of wood. The moulder dusts the wet mould with sand, rolls a homogeneous slug of soil on the table, called a clod. The clod has a volume of a little more than the mould. The clod is then lifted over the head and thrown with considerable force into the mould, where inertia forces it into every corner. The moulder then bumps the mould, cut off the surplus soil with a straight piece of metal, and the face is made smooth with a wet piece of wood.

The mould is carefully removed and the brick is carried on the

pallet to the drying ground. The bricks are removed from the pallet and it is brought back to moulding table.

The mould shown in Fig.1 can also be used.

Drying the Bricks

The simplest way to dry bricks are to place them on a level floor. The floor should have a roof. When clays which crack easily is used, the windward side should be covered in. Draughts should be avoided as they make one side dry quicker than the other, causing unequal contraction and consequent cracking. After two to three days the bricks are placed on edge.

Less space is required if the bricks are placed in a rack instead of directly on a floor. Rack drying is very suitable when a mould with many compartments is used (Fig.1). The pallets can then directly be placed in the rack.

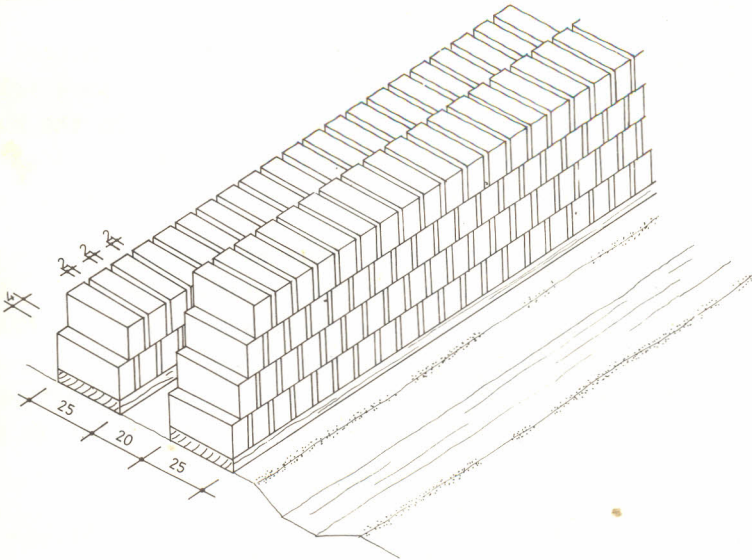

Fig.4. Drying of bricks. A stack with raised bottom.
(All dimensions in cm)

When sufficiently dry the bricks become hard enough to be stacked. This can be done on a flat open space. Fig.4 shows a stack with a raised bottom. The bricks are stacked on 25cm wide wooden planks in two rows which are placed 20 to 25cm apart. The distance between each brick should be 1 to 2cm. Each course has to be completed before a new one is started. The total height should not be more than 8 courses. Two meter long light moveable roof sections can be used to cover the stacks.

BRICK BURNING

The burning period in some places in Tanzania is much too short.

Burning of bricks is the most important stage in brick-making. The removal of the last traces of mechanically held water is the first stage in firing. Throughout the process of raising the temperature to between 950°C and 1,150°C and cooling back to ambient temperature, the clay is subjected to a series of changes in its physical properties, while complicated chemical reactions occur both within the separate mineral constituents and between the different minerals.

During all this time, size changes occur, first by thermal expansion, later by contraction due to a reduction in the pore volume on sintering and partial vitrification, then changes in the number of the pores. If the temperature is allowed to rise too high the volume and size change is caused by formation of glass.

The different processes mentioned occur at different temperatures, and the time interval required for completing them vary. A strict control of firing temperature is a great advantage, but this is possible only for large mechanized factories. To get a good result when the burning is done in a simple kiln requires great skill. We will below try to give some advice on brick-burning in simple kilns.

For a simple kiln, wood will be the most used fuel. Firewood will prove expensive if sufficient quantities are not available near by the kiln. For slow, steady combustion 15-25cm diam. logs (cut to 1 meter length) are much more satisfactory than scrub wood.

Again it will probably prove more efficient for large scale production to buy the firewood, cut to size from private wood-cutters. If firewood is more than a few hundred meters from the kilns (as is most likely the case), then trucks will be needed for transport.

Field Kiln

Building the Kiln

The field kiln is basically a stack of bricks spaced well apart so as to let heat pass evenly through all parts of the stack. At the base of the stack is left a tunnel for fire, and on the outside, the stack is sealed with soil to retain as much heat as possible within the stack.

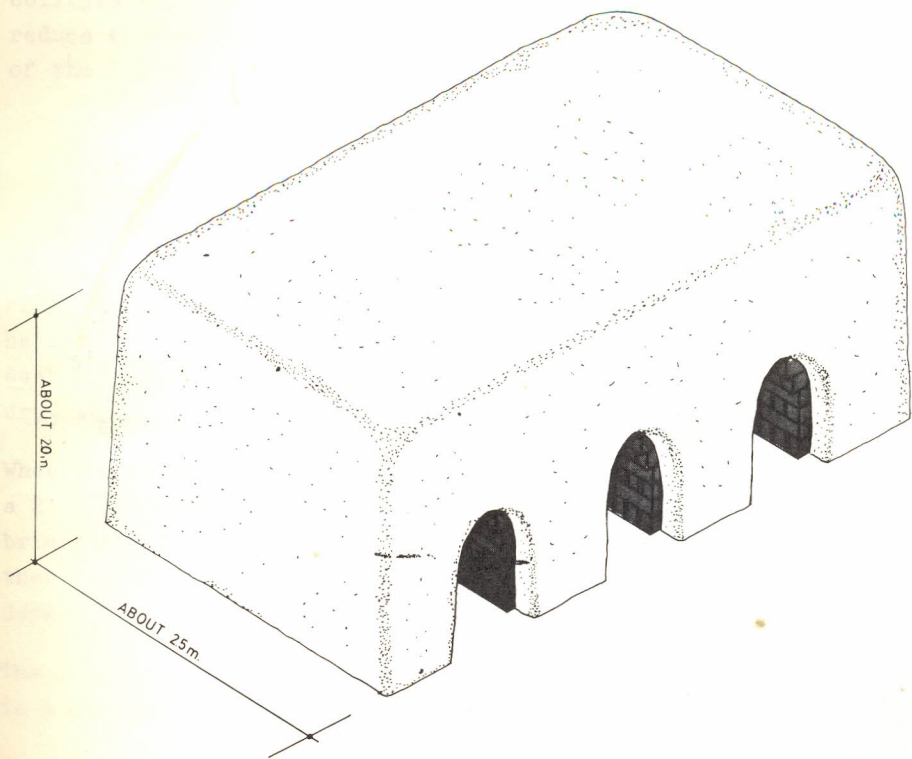

Fig.5. Field kiln with three fire tunnels ready for firing.

The size of the kiln may vary according to the number of bricks which are being made, the number of people working together etc. The kiln may thus have several tunnels, enlarging the kiln sideways as shown in Fig.5.

The distance from the front to the back should not be more than 2.5m. If longer, it will be difficult to get uniform firing throughout the length of the tunnel. Similarly, the height of the kiln should not be more than about 2.0m. to ensure that the upper layers of bricks will receive enough heat.

When starting to build the kiln, place the bricks on their sides on a level site and stack them as shown in Fig.6. Between each brick, there should be a gap of about 1cm to 1.5cm. The bricks of one layer should be at right angles to those of the layers above and below. The width of the tunnel should correspond roughly to the length of two bricks, and in order to bridge the tunnel, the first stone of the fifth and subsequent courses should project about 2.5cm beyond the brick immediately below it.

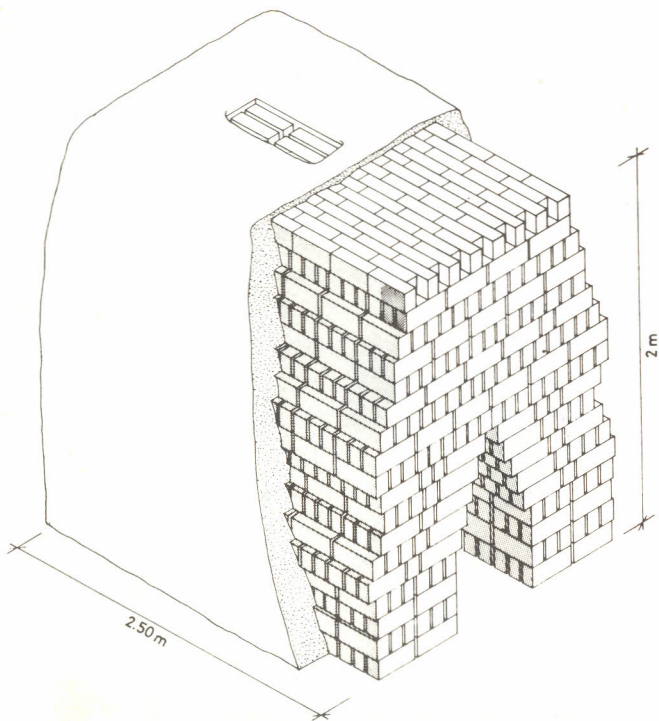

Fig.6. Field kiln partly covered with mud.

The wall between two tunnels (fig.5) should be equal to the length of three bricks.

In the topmost layer, the bricks should be placed close together to form a roof. For ventilation, space must be left between four of these bricks, as shown in Fig.6.

The kiln is improved if the green bricks are stacked on a foundation of underburnt bricks from last firing, instead of starting to build directly on the ground. The foundation has only to be a slab made up of bricks placed on edge.

When the stack is ready, it must be sealed by plastering all four sides with a layer of mud, 15cm to 20cm thick. The roof of the kiln must not be covered with mud at this stage.

The mud-plaster will be very much improved by inserting broken burnt bricks into it.

If care is taken in preparation of the stack as described above, this will ensure a strong stable stack which is not liable to collapse when the bricks shrink as the firing starts. It will also reduce the amount of firewood needed, improve the general quality of the bricks, and reduce waste.

Firing of Kiln

Fill the fire tunnels from both sides with dry wooden logs about half full. The fire should then be ignited from the leeward end of each tunnel. The fire should be kept dull until the bricks are dry, as evidenced by no more steam rising from the stack.

When the bricks are dry, the roof of the kiln must be covered with a 2 to 3cm thick layer of mud, only leaving openings around a few bricks for ventilation over each tunnel (Fig.6). More logs should then be added and the fire kept burning briskly for four to five days.

The fire requires attention every few hours. The firing of a kiln is a continuous job, night and day.

If a lot of cow-dung is available it can be used to improve the burning of the top courses. The covering of the top is then done

differently. When the bricks are dry, the fire is boosted up with more firewood. When, from the top, the glow of the fire can be seen below, the top is covered with a mixture of soil and dried cow-dung. The layer should be about 10cm thick. The cow-dung layer will burn without flame when the fire from below reaches it, and finishes off the two or three top courses which otherwise might have been underburnt.

Inspect the bricks by scraping off some soil from the middle of the side of the stack and remove two or three bricks. If burning has been completed, the bricks will be difficult to break, and when struck they will produce a metallic sound. If the sound is dull, firing should be continued.

In places where it is blowing steadily, it will be advantageous to burn from one side at a time. This is done by closing one end of the tunnel, and firing for half of the time from one side. The closed side is then opened, the other is closed, and the process is repeated.

After proper burning the kiln must be sealed off by closing all openings with old bricks and mud. The kiln is then allowed to cool off for several days. The slower the cooling the tougher the bricks will be. On examining the bricks, it will be found that ten to fifteen out of hundred bricks are either broken or not fit for use. If more than twenty out of hundred bricks are broken, more care must be taken in making, stacking and burning the bricks.

The underburnt bricks should be kept for flooring of the next kiln, or for refiring. The over-burnt bricks can be broken and used for aggregate for concrete or it can be added to the soil to reduce plasticity (see section 3).

Permanent Kilns

Where bricks are continuously produced for sale it may be an advantage to build a permanent kiln. The simplest of these are stacked and burnt the same way as a field kiln.

The disadvantages with a field kiln is that the foundation and the outside mud plaster has to be rebuilt every time. This is time consuming. The mud plaster has also a tendency to fall off, which

cools down the kiln. Rain and strong winds do the same, with poor bricks as a result.

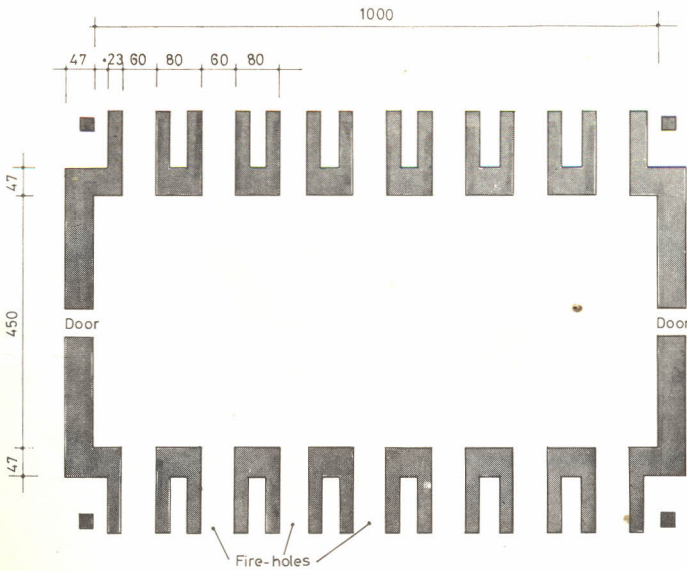
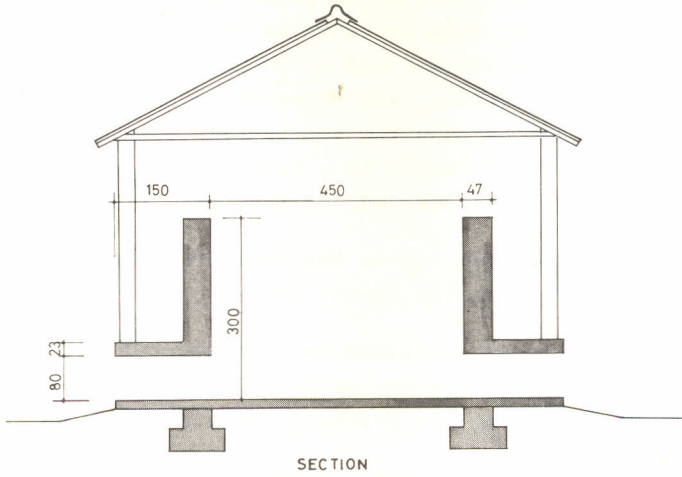

Fig.7. Rectangular permanent kiln with a raised roof. Capacity about 40,000 bricks. (All dimensions in cm)

The production can start with burning in a field kiln. With bricks from this production a permanent kiln can be built. Where the demand is fluctuating it is uneconomical to build permanent kilns for the total production. A field kiln can be used to absorb the variations.

A permanent kiln is a kiln which has permanent foundations, walls and roof. A rectangular kiln is shown on Fig.7. The side walls have arched fire holes, and the end walls narrow doors which are temporarily closed for firing, and reopened for unloading of bricks. No chimney is required because the top is left open, under the raised roof. The kiln is loaded to a height of 20 - 25 courses. The top may be covered the same way as the field kiln.

The firing is done the same way as described for the field kiln, but the burning period can usually be cut down.

A kiln of this type loses considerable heat through the top. If the necessary skill is available, an arched permanent top with holes to produce draught, can be constructed. This saves fuel.

A circular kiln is shown on Fig.8. This kiln shape has proved to produce bricks of even quality. A circular kiln can also easily be dug into the ground if it is placed on a slope. This will result in a kiln which is partly under ground, which again reduces the

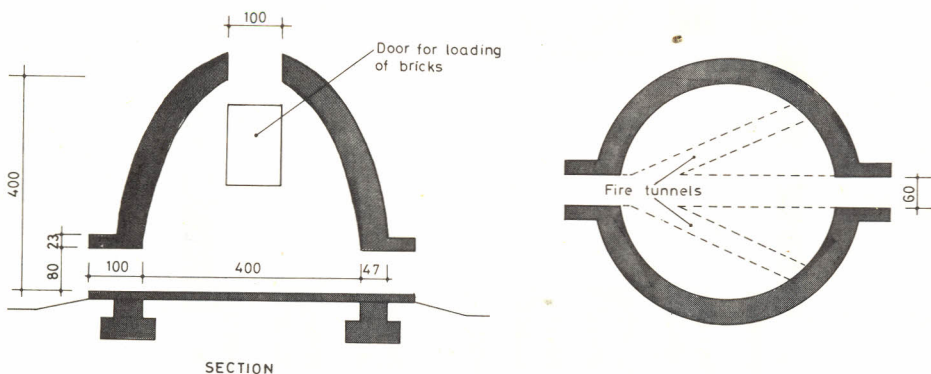

Fig.8. Circular permanent kiln. Capacity about 15,000 bricks. (All dimensions in cm)

temperature gradient, reduces fuel consumption, increases the cooling period and makes it easier to load the kiln from different levels. All of these factors improve quality.

A circular kiln may only have two arched fire opening, but these may be branched out to form three fire tunnels as shown on Fig.8.

SOIL SUITABILITY FOR BRICK-MAKING

A high quality brick require a very good soil. Great care should therefore be used when the soil is selected.

Soils may be divided roughly into five types according to particle size, with gravel at one end of the scale, and organic soil at the other end. In between we have sand, silt and clay. Gravel consists of pieces of rock from 1mm upwards and are useless for brick production. So are also the organic soils which are usually darkish in colour, containing fibrous or vegetable matter, and when wet are spongy and may have a sour smell. Clay, silt and sand occur seldom seperately with exception of the last. This is perhaps fortunate because not one of the three on its own constitutes a good material for brick production.

Any soil possessing plasticity can be made into a brick. Soils containing a high proportion of clay, may have to be mixed with a non plastic material, e.g. sand, to reduce the contraction on drying to avoid cracking. Where sand is not available underburnt bricks may be crushed and mixed into the soil. Another method of dealing with very plastic soils is to add some form of chopped vegetable fibre, e.g. grass, waste cotton or sisal fibre. These materials burn out on firing, and decreases the strength of the brick to some extent, but the burning is usually more thorough. Generally it can be said that the more plastic the soil, the greater its contraction and the greater its tendency to crack.

Roughly it can be said that the properties of a soil suitable for making bricks are :-

Clay content	15 to 30%
Silt content	20 to 65%
Liquid Limit	25 - 40%
Plasticity Index	7 - 15%

Before a large scale brick production is started thorough laboratory tests have to be carried out, and the size of the clay deposits have to be determined.

We will now give a few simple rules which are a good enough guide for hand production.

After having selected a site for prospecting, soil samples have to be collected from different places on the site. On these spots, the topsoil, which contains organic (vegetable) matter, must be removed to a depth of approximately 0,5m. Under the top-soil is often a layer of sand which merges into a clay as the depth increases. Further down, the clay will get harder and may contain smaller or bigger pieces of stone.

A pit, 1,5 - 2m deep will usually reveal the different soil layers. The best soil, from which the samples should be taken, is found just under the sand layer where the soil has a proportion of sand mixed with it and is free from stones.

Testing the Soil

Collect a shovelful of the soil which looks the best from each pit. Then crush the samples carefully removing all stones.

Slowly add water to the sample, mixing thoroughly, until the soil becomes plastic and can be pressed into different shapes with the hands.

If the soil is difficult to make into a shape, or keeps falling apart, the soil contains too much silt or sand and cannot be used for making good bricks.

Take a handful of soil which can be moulded and form a ball, a little smaller than a hen's egg, by rolling the soil between the hands. Repeat this for all the remaining samples. Then leave the balls in the sun for drying.

- a. The ball which retain its shape when drying, is very hard, but has wide cracks does not contain enough sand or silt.
- b. The ball which tend to deform and crumbles easily when dry contains too much sand or silt and can not be used for brick-making.

c. The ball which shows the least deformity and shows no cracks, or very fine ones, contains the soil which is best suited for this purpose.

The soil of the ball which shows wide cracks after drying can be improved by adding the required amount of sand. The right proportioning is found by adding small amounts of sand and making balls as described above. The ball which shows the least deformation and the smallest cracks has the best mix.

The soil which has been found successful in these tests must also be tried for moulding. This is done by mixing the soil thoroughly and pressing it into the mould. If the mixture is too stiff or dry it will not completely fill the mould and the edges and corners will not be sharp and well-defined. Additional water should then be added until well formed bricks can be moulded.

If several soil samples have been found to be satisfactory, sample bricks should be made and burnt from all of them. On this basis a final choice should be done.

STANDARDIZATION OF BRICKS

To standardize a product means to specify certain properties and qualities it have to meet.

When burnt clay bricks are used for smaller and self-help projects standardization is today not very important. But if the bricks are sold or if they are used for larger project standardization is vital. When a large project is planned, qualities and sizes of bricks have to be known. Lack of standardization of brick sizes and quality prevents smaller producers of hand-made bricks from joining forces and producing for larger projects.

Many planners do not regard burnt clay bricks as an alternative because they do not know what they will get. A standardization of brick size, compression strength and mortar is required if promotion of burnt clay bricks shall be a success.

We will to some extent discuss these problems, but we will not go very far. Standardization is difficult. Too rigid and wrong standards will hamper the development instead of promoting it.

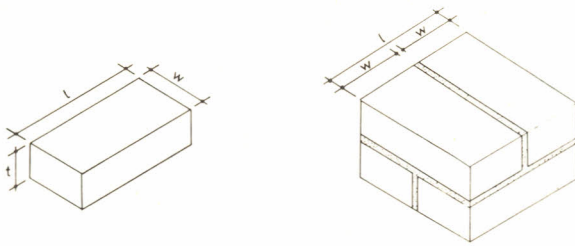

Fig.9. Relation between length and width of a brick.

Brick Size

Figure 9 show a brick. The different dimensions are given as l (length), w (width), t (thickness). There are many variables to take into account before the dimensions are standardized. We will here mention some of them. Because of the way we build brick walls there have to be a certain relation between length (l) and width (w). In fig.9 this is shown. (Length is two times the width plus the joint thickness). For high and medium loaded external brick walls a thickness equal to the length of a brick is used. Internal walls and lightly loaded external walls can have a thickness equal to the brick width (w). Each of these solutions require a minimum thickness. When the brick dimensions are standardized these minimum thicknesses have to be taken into account. Furthermore, the bricks have to have such dimensions that the size of window and door openings will be in whole multiples of 10cm. This is, perhaps, not very imporant today, but when large prefabricated production of doors, windows, etc. is started, it will be important. The brick sizes will also influence production. The method of drying and burning of bricks will restrict the size.

Fig.10 shows a brick-wall where a brick size of 23cm x 11cm x 6.5cm is used. The joint thickness is assumed to be 1cm. It is never possible to produce bricks which have an exact size. They will therefore vary in size. These variations have also to be standardized. But we will not discuss this here. Our recommendation is that the maximum brick size should be 23cm x 11cm x 6.5cm.

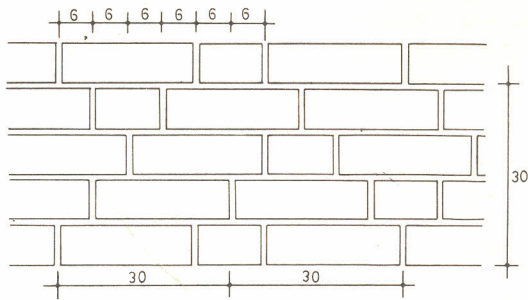

Fig.10. Brick-wall where 23cm x 11cm x 6.5cm bricks are used.

112 bricks are needed for every sq.m. wall if the thickness is equal to the length of a brick, and 56 bricks if the thickness is equal to the brick width.

At BRU we will also try out a brick size of 25.6cm x 12.3cm x 9cm. Fig. 11 shows how this brick can be used.

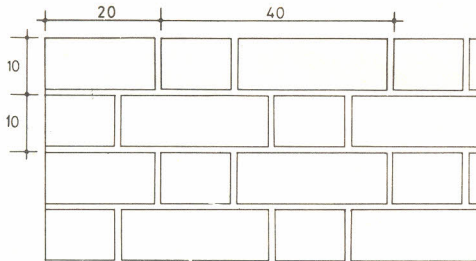

Fig.11. Brick-wall where 23cm x 11cm x 6.5cm bricks are used.

Compression Strength

Before bricks can be used in heavily loaded structures minimum compression strengths have to be guaranteed by producers, and these have to be proved by continuous laboratory tests. But it will take some time before this can be a reality.

In some countries they specify a brick quality by giving the dry density of the brick they need. This is because there are a reliable relation between dry density and compression strength for well burnt bricks. To determine the dry density is simple and can be done everywhere. The National Housing and Building Research Unit (BRU) will obtain bricks from different producers, and we will try to establish this relation for Tanzanian conditions.

But a few simple rules for determining structural quality can be used. First-class bricks should be uniform in size and colour, and without cracks and distortion. When struck they should produce a metallic sound. A rough strength test is to hold two bricks edge-wise, crossed and touching, one over the other. The bricks should be dropped together from about 1.2m over ground. With good bricks, neither should break. The tests should be repeated with the top-brick wet, soaked in water for a day, if the wet one does not break the bricks can be reckoned very good.

Mortar

The load capacity of a brick wall is determined by the compression strength of the bricks, strength of mortar, dimensions of the wall and the quality of work. We will here briefly talk about mortar design and relate this to the strength of the wall.

A lime mortar gains strength very slowly. The curing of lime mortar require that the mortar has a certain but small water content. This water content is equivalent to a relative humidity in the air of 65% to 75%. This mean that it is probably only at the coast that a lime mortar will gain full strength. A lime mortar is also very sensitive to joint thickness. The strength of the brick wall may be reduced by as much as 30% if the joint thickness is increased from 1 to 2cm. The bricks should also preferably be dry when used. When a lime mortar is used it is easy to lay the bricks.

A cement mortar has a much higher strength than a lime mortar, and it gains strength much faster. A cement mortar has to be used within 1½ hour after it has been made. Cement needs water to gain strength. The wall should therefore preferably be kept moist. When bricks with a compression strength below 100 kgf/cm² are used the full strength of the mortar can not be utilized. It is more difficult to lay the bricks in cement mortar than in lime mortar.

A lime-cement mortar combines the advantages of cement and lime. The ratio between lime and cement should be inside certain limits. If too little cement is used, the cement will not help the mortar to gain strength. The cement grains will hydrate separately and form sand-like grains. If too much cement is used the lime will not gain strength. Advantages of lime-cement mortars are high strength, good workability and when the lime hardens it separates out water which the cement can utilize in gaining strength.

The table below gives a few mortar designs (all ratios are given in volumes). The strength of a brick wall which has a thickness equal to the length of one brick is also given. These values are only approximate. It is assumed that the workmanship is good and that the joints are about 1cm. thick. The values indicate only the transformation from mortar strength and brick strength to wall strength. No adjustments have been taken for variations in load, quality of workmanship, sizes of eccentricities and slenderness etc.

Mortar type	Sand	Lime	Cement	Compressive strength of brick in kgf/cm ² .	Compressive strength of wall in kgf/cm ² .
Lime	4	1		40	10 - 15
"	"	"		100	20 - 25
Cement	4		1	40	30 - 35
"	"		"	100	70 - 80
Lime-cement	12	2	1	40	25 - 30
"	"	"	"	100	35 - 40
Lime-cement	8	1	1	40	30 - 35
"	"	1	1	100	45 - 50

The table indicates that for small house a lime mortar is good enough. But for larger buildings one or another lime-cement or cement mortar will be needed when the structural quality of the brick is low.